

Pinned_Photodiode_Patents_by_Yoshiaki_Hagiwara

The following slides explain the details of 1975_Pinned_Photodiode_Patent.

Artificial Intelligent Partner System(AIPS) Home Page Top
hagiwara-yoshiaki@aiplab.com

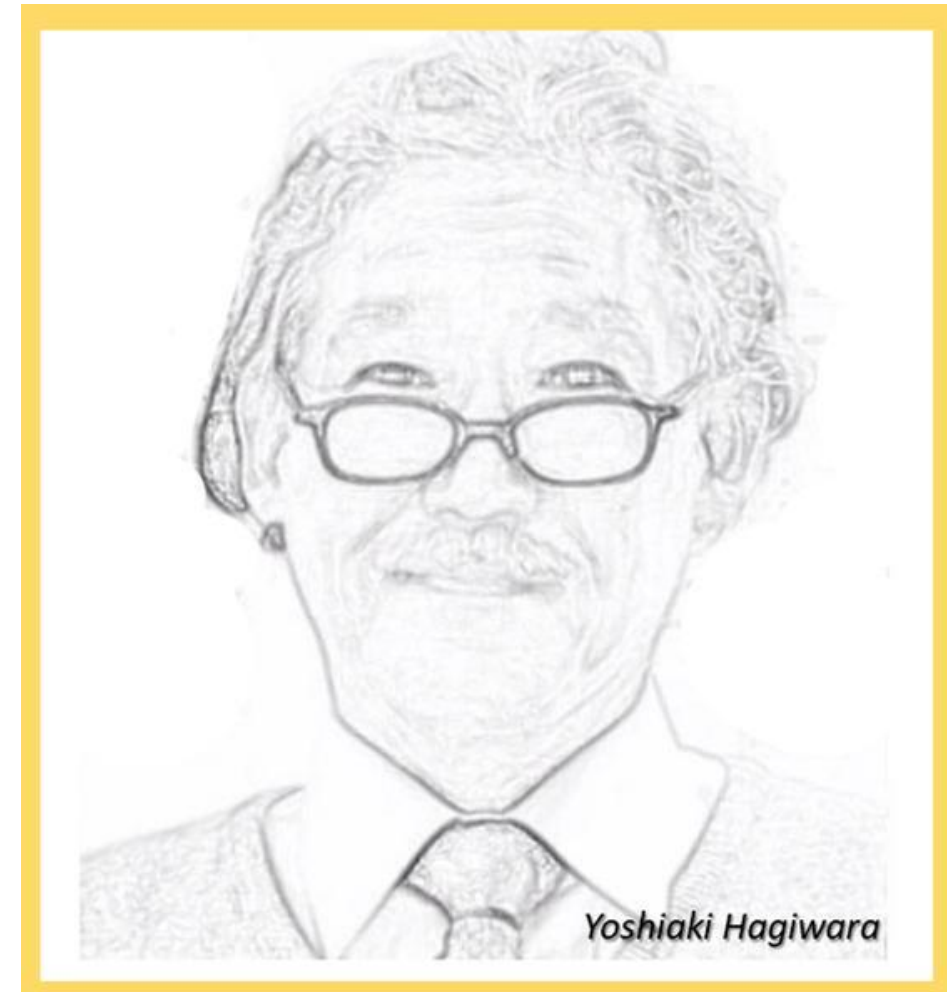

Pinned_Photodiode_Patents_by_Yoshiaki_Hagiwara

Pinned Photodiode is defined as one special type of Buried Photodiode.

Pinned Photodiode must have a flat surface potential with no surface electric field in order to suppress the undesired surface dark current. Pinned_Photodiode must have a fixed flat surface potential pinned by an adjacent channel stops or directly connected by an adjacent metal contact nearby. Otherwise, the surface potential would become floating because of the undesired RC delay time.

Pinned Photodiode must always have the majority carrier accumulation surface layer and also with the minority carriers surface barrier electric field in order to achieve effectively the electron and hole photo pair generation at the majority carrier surface accumulation layer within the depth of less than $0.1 \mu\text{m}$, which results in an excellent short wave blue light sensitivity.

Pinned Photodiode is by necessity always Buried Photodiode.

But Buried Photodiode is not always Pinned Photodiode

Pinned_Photodiode_Patents_by_Yoshiaki_Hagiwara

Pinned Photodiode always by necessity must have the pinned empty potential well in the buried photo charge collecting and storing region so that when reset the signal photo charge can be drained completely and no image lag feature is achieved.

Before 1970 when CCD was invented by Boyle and Smith, the N+P single junction type Photodiode was used with the undesired image lag problem. The surface channel type CCD has a serious surface charge trapping noise problem with a very poor charge transfer efficiency. However, the buried channel type CCD has an excellent charge transfer efficiency of about 99.999%. The picture size of the NTSC

Format is about 800H x 500V. And at most the charge transfer of $800+500 = 1300$ is needed in the NTSC TV system. This observation gives the image information loss of $0.001\% \times 13000 = 1.3\%$ which is small enough for human eyes since human eyes cannot recognize the picture noise of less than 3%. CCD became a super star in the Image sensor world in the analog TV era from 1980 to 2000.

The first commercially available two-chip CCD video camera with the CCD/MOS dynamic capacitor type photo detecting device (PDD) was introduced by Sony in 1980 and was used in the cock pit of ANA Jumbo 747 which gave the excellent and clear action pictures of the completely no image lag feature .

(1) N+P junction Photodiode
in 1960s

The N+ surface is floating.

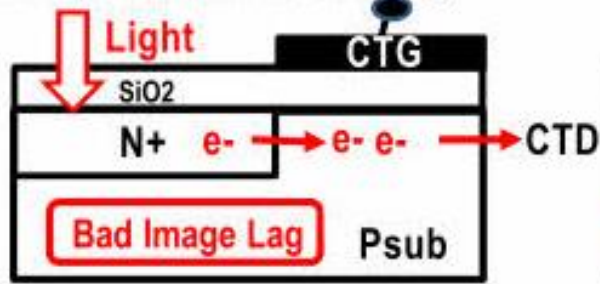

Oxide Capacitance Coupling and
Serious Image Lag Problem

(2) Transparent Electrode CCD/MOS Photo Capacitor (1980)

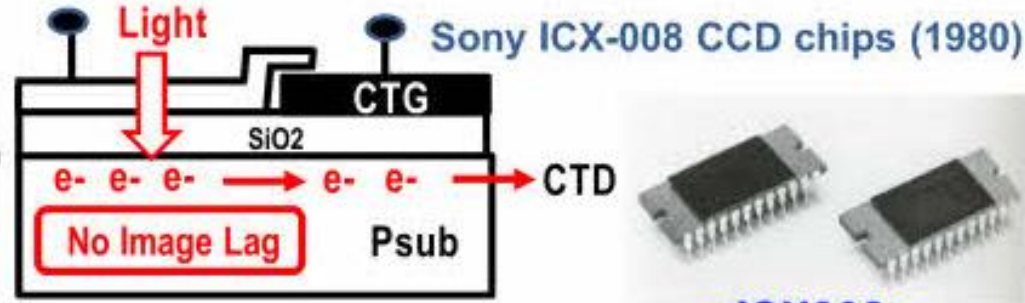

<ICX008>

XC-1 1980
Two-Chip Color Video
Camera

on ANA 747 Jumbo Jet



all solid state = robustness

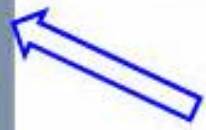

- CCD/MOS Dynamic Photo Capacitor
with no image lag for action pictures
with Electric Shutter Function

Hagiwara invented Pinned Photodiode (PPD).

Japanese Patent Applications, JPA1975-127646, JPA1975-127647 and JPA 1975-134985, filed by Yoshiaki Hagiwara at Sony in 1975, show that Hagiwara invented Buried Photodiode (BPD) with the Pinned Surface Hole Accumulation, Pinned Photodiode (PPD) and Hole Accumulation Diode (HAD). It is also evident that Hagiwara invented Global Shutter Scheme of the three level clocking with MOS Capacitor Buffer Memory, clearly shown in JPA 1975-127646 and JPA 1975-127647. It is also evident that Hagiwara et al invented the Electrical Shutter Clocking Scheme by controlling punch-thru action of the in-pixel overflow drain (OFD) voltage as evidenced in JPA 1977-136885.

Comparison of Various Light Detecting Photo Sensor Structures

| feature \ type | Classical N+Psub Photodiode | Surface Channel CCD | Buried Channel CCD | Yamada 1978 NPNSub | Teranishi 1980 PNPsub | Hagiwara 1975 PNPNSub |
|------------------------|-----------------------------|---------------------|--------------------|--------------------|-----------------------|-----------------------|
| Blue Light Sensitivity | △ | X | X | ○ | ○ | ○ |
| Low Image Lag | X | ○ | ○ | X | ○ | ○ |
| Surface Dark Current | ○ | X | X | X | ○ | ○ |
| Surface Trap Noise | ○ | X | ○ | X | ○ | ○ |
| Vertical OFD (VOD) | X | X | X | ○ | X | ○ |
| Electrical Shutter | X | X | X | X | X | ○ |

Hagiwara invented Pinned Photodiode (PPD).

Japanese Patent Applications, JPA1975-127646, JPA1975-127647 and JPA 1975-134985, filed by Yoshiaki Hagiwara at Sony in 1975, show that Hagiwara invented Buried Photodiode (BPD) with the Pinned Surface Hole Accumulation, Pinned Photodiode (PPD) and Hole Accumulation Diode (HAD). It is also evident that Hagiwara invented Global Shutter Scheme of the three level clocking with MOS Capacitor Buffer Memory, clearly shown in JPA 1975-127646 and JPA 1975-127647. It is also evident that Hagiwara et al invented the Electrical Shutter Clocking Scheme by controlling punch-thru action of the in-pixel overflow drain (OFD) voltage as evidenced in JPA 1977-136885.

(1) N+P junction Photodiode in 1960s

Poor Blue Light Sensitivity Problem

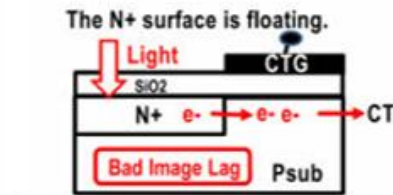
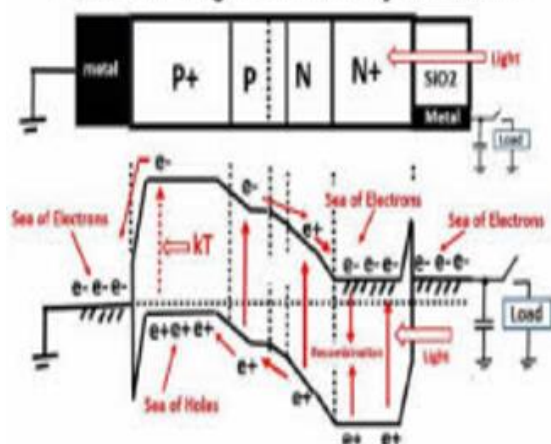

(2) Transparent Electrode CCD/MOS Photo Capacitor (1980)

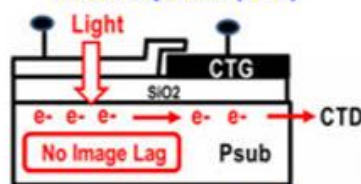

Sony ICX008, 1980

(3) JPA 1975-134985 by Hagiwara

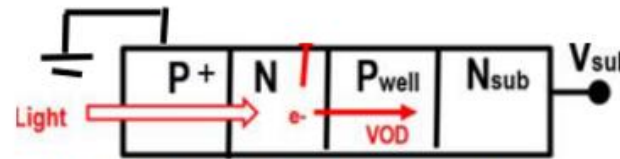

(4) JPA 1978-1971 by Yamada

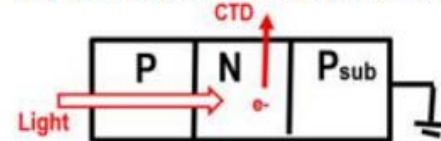

(5) JPA 1980-138026 by Teranishi

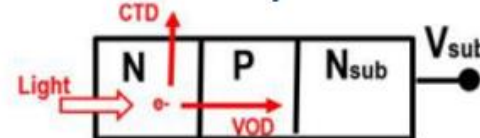

Before 1970 when CCD was invented by Boyle and Smith, the N+P single junction type Photodiode was used with the undesired image lag problem.

(1) N+P junction Photodiode
in 1960s

The N+ surface is floating.

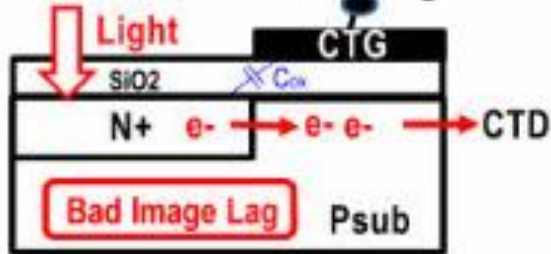

Oxide Capacitance Coupling also gives the Serious Image Lag Problem

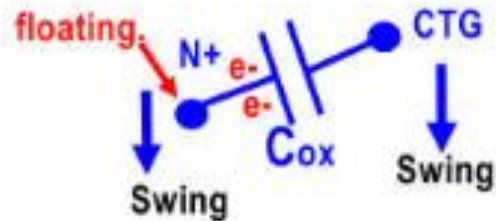

$$I_{ds} = K (V_s - V_{ch})^2$$

$$\text{As } (V_s - V_{ch}) \rightarrow 0$$

$$I_{ds} \rightarrow 0$$

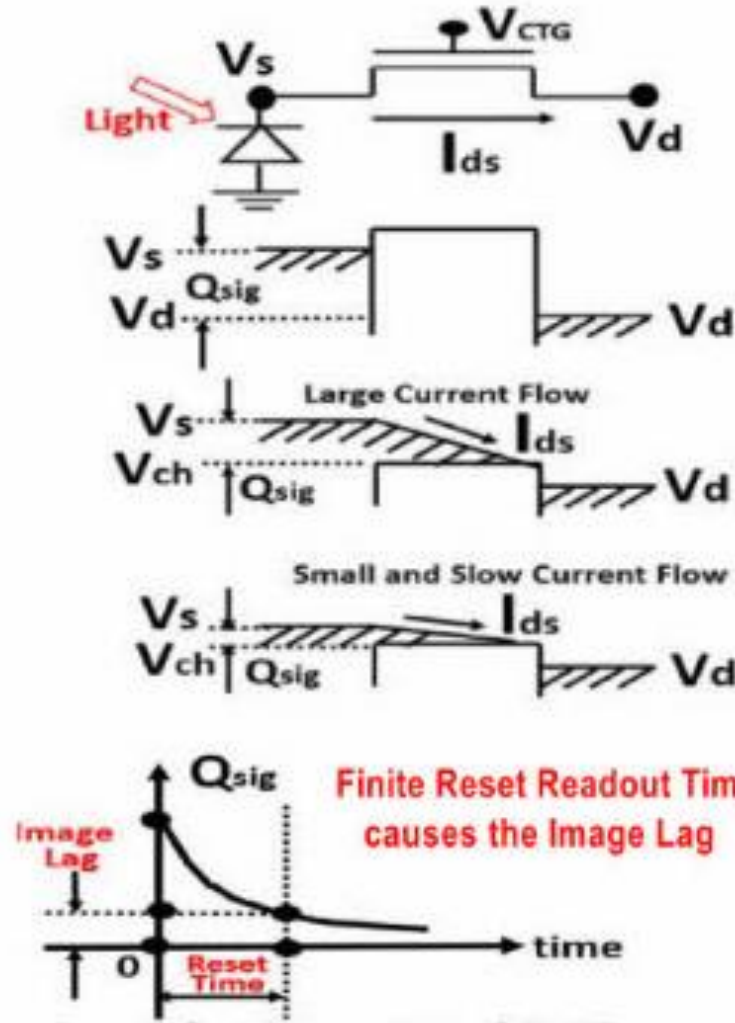

Hagiwara invented Pinned Photodiode (PPD).

Japanese Patent Applications, JPA1975-127646, JPA1975-127647 and JPA 1975-134985, filed by Yoshiaki Hagiwara at Sony in 1975, show that Hagiwara invented Buried Photodiode (BPD) with the Pinned Surface Hole Accumulation, Pinned Photodiode (PPD) and Hole Accumulation Diode (HAD). It is also evident that Hagiwara invented Global Shutter Scheme of the three level clocking with MOS Capacitor Buffer Memory, clearly shown in JPA 1975-127646 and JPA 1975-127647. It is also evident that Hagiwara et al invented the Electrical Shutter Clocking Scheme by controlling punch-thru action of the in-pixel overflow drain (OFD) voltage as evidenced in JPA 1977-136885.

Before 1970 when CCD was invented by Boyle and Smith, the N+P single junction type Photodiode was used with the undesired image lag problem.

More Problem

Poor Blue Light Sensitivity Problem

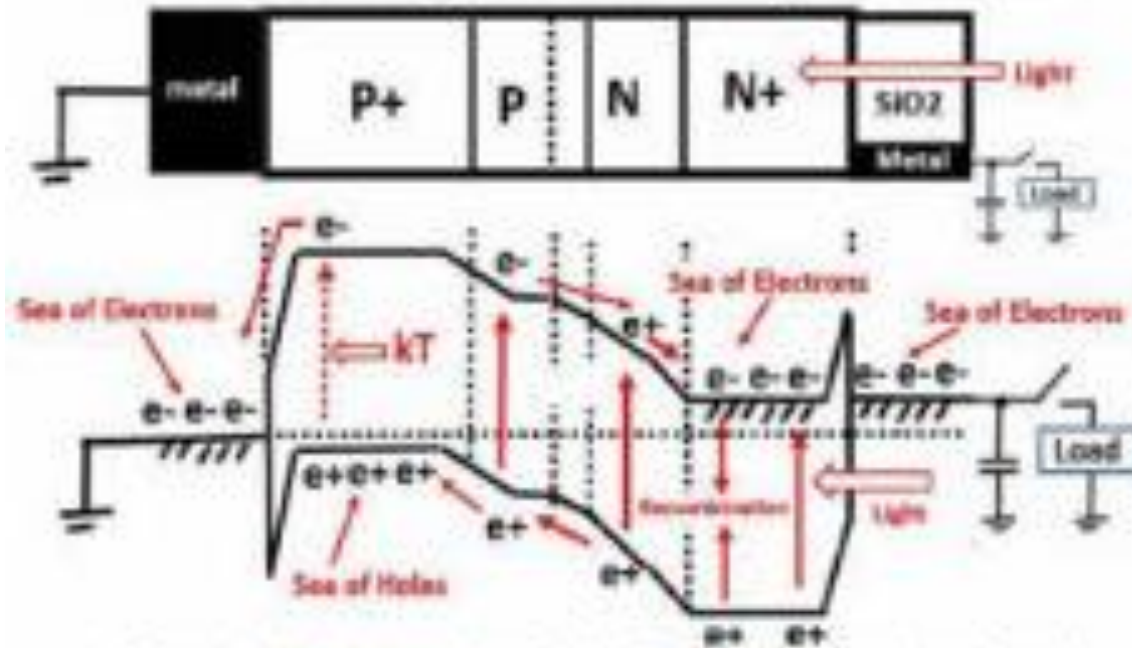

Single Junction N+P type Solar Cell also has a very poor short wave blue light sensitivity.

Hagiwara invented Pinned Photodiode (PPD).

Japanese Patent Applications, JPA1975-127646, JPA1975-127647 and JPA 1975-134985, filed by Yoshiaki Hagiwara at Sony in 1975, show that Hagiwara invented Buried Photodiode (BPD) with the Pinned Surface Hole Accumulation, Pinned Photodiode (PPD) and Hole Accumulation Diode (HAD). It is also evident that Hagiwara invented Global Shutter Scheme of the three level clocking with MOS Capacitor Buffer Memory, clearly shown in JPA 1975-127646 and JPA 1975-127647. It is also evident that Hagiwara et al invented the Electrical Shutter Clocking Scheme by controlling punch-thru action of the in-pixel overflow drain (OFD) voltage as evidenced in JPA 1977-136885.

The N+PNP junction type Dynamic Photo Transistor Structure
 Pinned Photodiode and Sony Hole Accumulation Diode (HAD)
 with the vertical overflow drain (VOD) function
 invented by Hagiwara at Sony in 1975

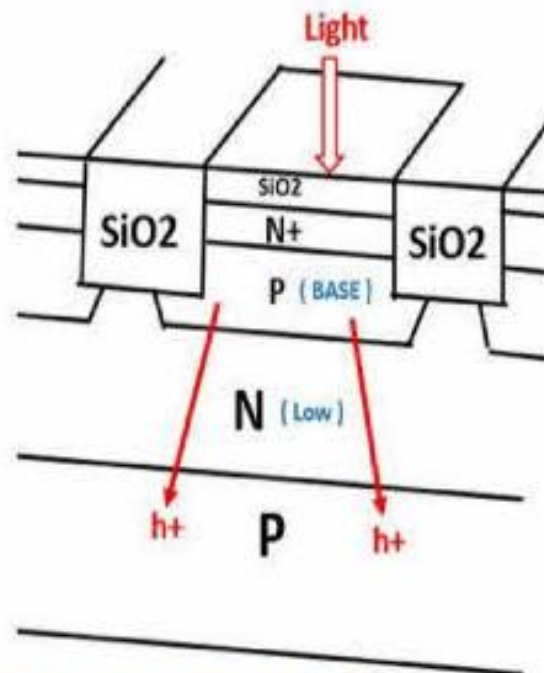
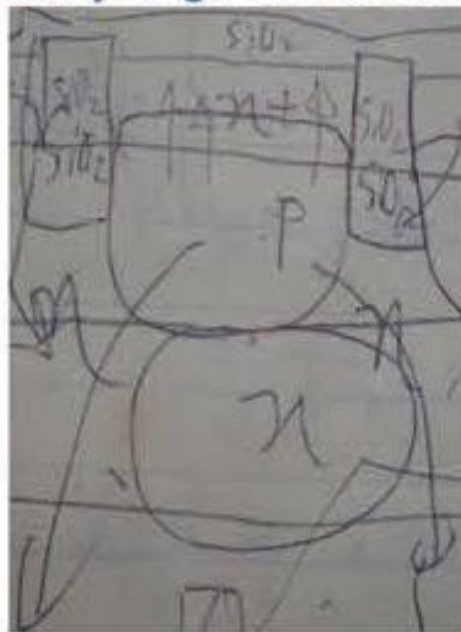
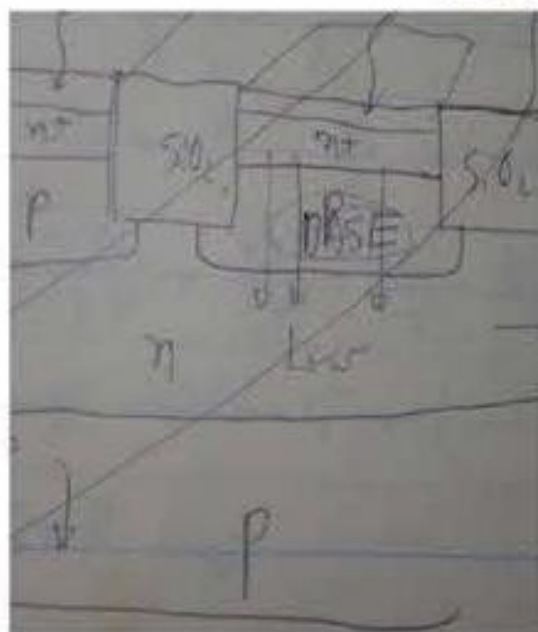

Hagiwara's Lab Note at Sony in February 1975

In 1975 at Sony, Yoshiaki Hagiwara filed three Japanese patents JPA1975-127646, JPA1975-127647 and JPA1975-134985 on the Pinned Surface Photodiode with the VOD function which is later called as Sony Hole Accumulation Diode (HAD).

Hagiwara did not file a patent on the SiO₂ device isolation but this lab note shows that Hagiwara had an idea of forming the Shallow Trench Isolation by the Local Oxidation Method, which was hinted by the LOCOS isolation in 1970s.

Hagiwara invented Pinned Photodiode (PPD).

Japanese Patent Applications, JPA1975-127646, JPA1975-127647 and JPA 1975-134985, filed by Yoshiaki Hagiwara at Sony in 1975, show that Hagiwara invented Buried Photodiode (BPD) with the Pinned Surface Hole Accumulation, Pinned Photodiode (PPD) and Hole Accumulation Diode (HAD). It is also evident that Hagiwara invented Global Shutter Scheme of the three level clocking with MOS Capacitor Buffer Memory, clearly shown in JPA 1975-127646 and JPA 1975-127647. It is also evident that Hagiwara et al invented the Electrical Shutter Clocking Scheme by controlling punch-thru action of the in-pixel overflow drain (OFD) voltage as evidenced in JPA 1977-136885.

Pinned Photodiode must always have the majority carrier accumulation surface layer and also with the minority carriers surface barrier electric field in order to achieve effectively the electron and hole photo pair generation at the majority carrier surface accumulation layer within the depth of less than $0.1 \mu\text{m}$, which results in an excellent short wave blue light sensitivity

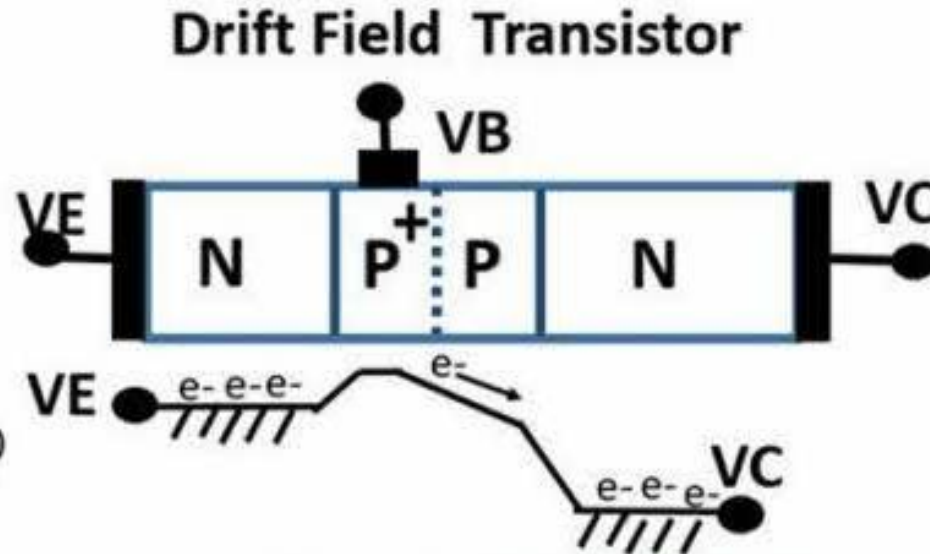
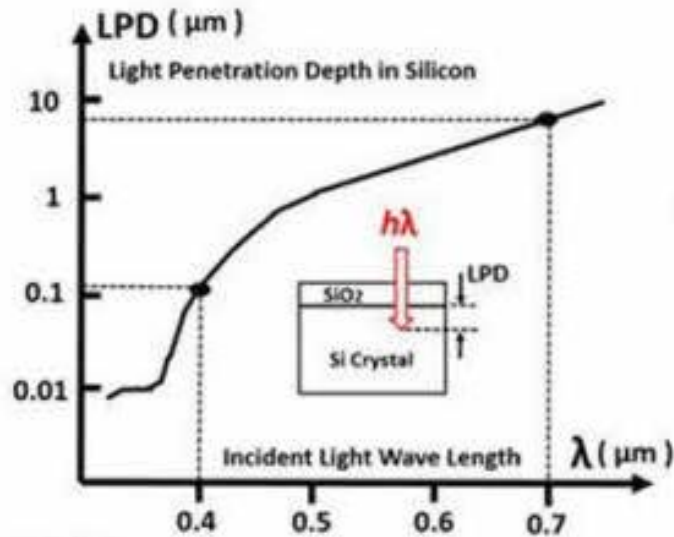

Hagiwara invented Pinned Photodiode (PPD).

Japanese Patent Applications, JPA1975-127646, JPA1975-127647 and JPA 1975-134985, filed by Yoshiaki Hagiwara at Sony in 1975, show that Hagiwara invented Buried Photodiode (BPD) with the Pinned Surface Hole Accumulation, Pinned Photodiode (PPD) and Hole Accumulation Diode (HAD). It is also evident that Hagiwara invented Global Shutter Scheme of the three level clocking with MOS Capacitor Buffer Memory, clearly shown in JPA 1975-127646 and JPA 1975-127647. It is also evident that Hagiwara et al invented the Electrical Shutter Clocking Scheme by controlling punch-thru action of the in-pixel overflow drain (OFD) voltage as evidenced in JPA 1977-136885.

Pinned Photodiode must always have the majority carrier accumulation surface layer and also with the minority carriers surface barrier electric field in order to achieve effectively the electron and hole photo pair generation at the majority carrier surface accumulation layer within the depth of less than $0.1 \mu\text{m}$, which results in an excellent short wave blue light sensitivity

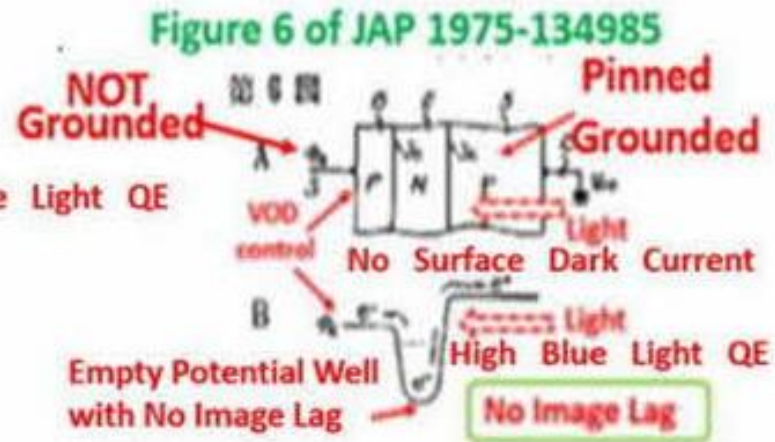
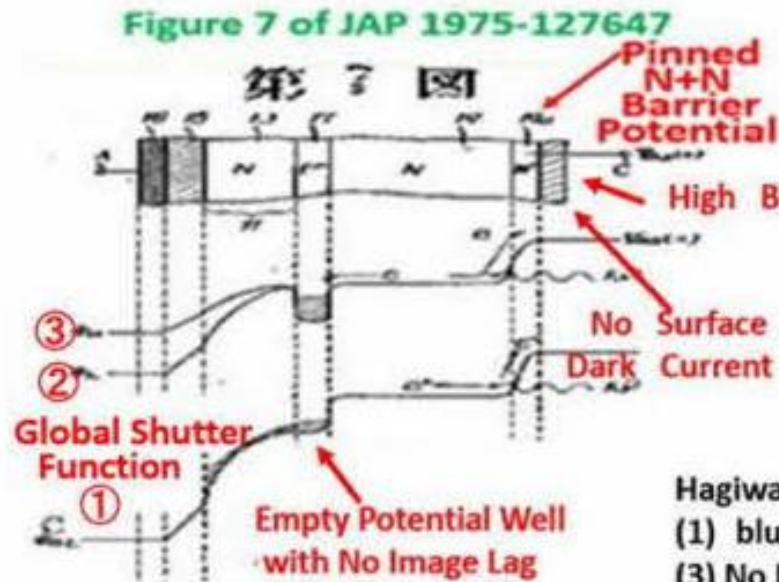

Hagiwara invented PNP junction type PPD in 1975 with (1) blue light 100% QE, (2) No Surface Dark Current and (3) No Image Lag, Complete Charge Transfer features.

Hagiwara invented Pinned Photodiode (PPD).

Japanese Patent Applications, JPA1975-127646, JPA1975-127647 and JPA 1975-134985, filed by Yoshiaki Hagiwara at Sony in 1975, show that Hagiwara invented Buried Photodiode (BPD) with the Pinned Surface Hole Accumulation, Pinned Photodiode (PPD) and Hole Accumulation Diode (HAD). It is also evident that Hagiwara invented Global Shutter Scheme of the three level clocking with MOS Capacitor Buffer Memory, clearly shown in JPA 1975-127646 and JPA 1975-127647. It is also evident that Hagiwara et al invented the Electrical Shutter Clocking Scheme by controlling punch-thru action of the in-pixel overflow drain (OFD) voltage as evidenced in JPA 1977-136885.

Japanese Patent Application JPA 1975-127646

applied by Yoshiaki Hagiwara at Sony on October 23, 1975

File 1975-127646 Filed 1975/10/23
Public 1977-051815 on 1977/04/26

Buried Pinned Photodiode Patent

the NPN Triple Junction type

Dynamic Photo Thyristor

with P-type Charge Carrier (h^+) Buried Channel
CCD/MOS Dynamic Capacitor type Buffer Memory
used for Instant Photo Charge (h^+) Storage
to achieve Global Shutter Function

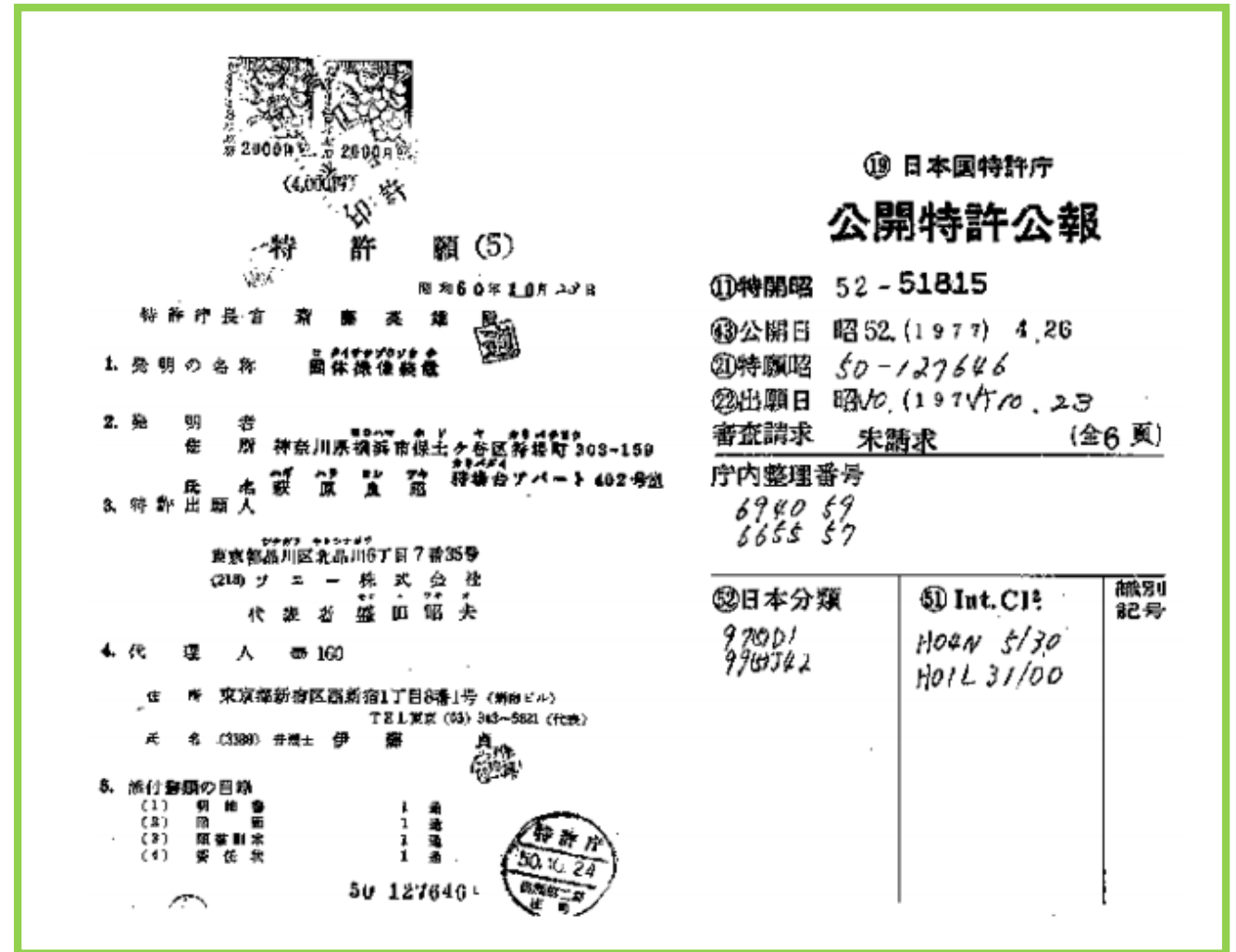
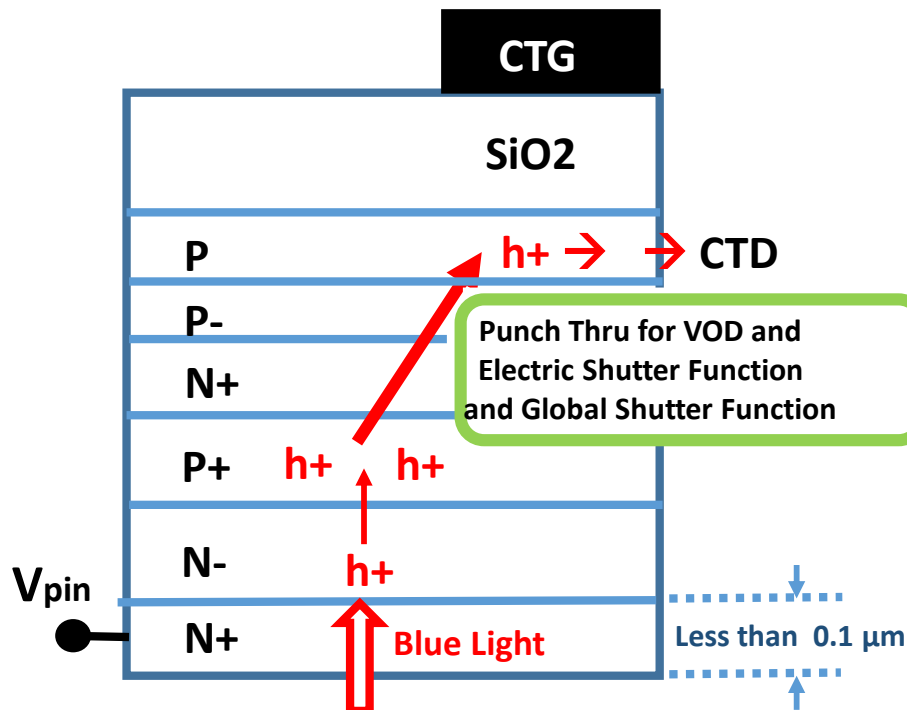

Title Page of JPA 1975-127646
applied by Yoshiaki Hagiwara at Sony in 1975

Japanese Patent Application JPA 1975-127646

applied by Yoshiaki Hagiwara at Sony on October 23, 1975

File 1975-127646 Filed 1975/10/23
Public 1977-051815 on 1977/04/26

Buried Pinned Photodiode Patent

the NPNP Triple Junction type

Dynamic Photo Thyristor

with P-type Charge Carrier (h+) Buried Channel

CCD/MOS Dynamic Capacitor type Buffer Memory

used for Instant Photo Charge (h+) Storage

to achieve Global Shutter Function

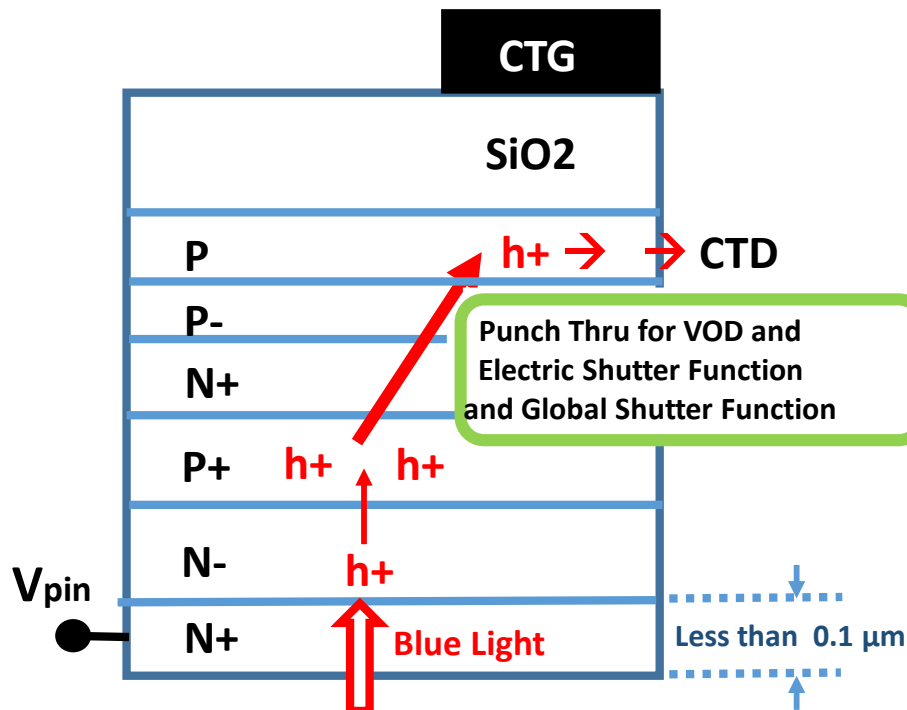

| 明 示 書 | 明 示 書 |
|---------|---|
| 発明の名称 | 固体撮像装置 |
| 特許請求の範囲 | <p>半導体基体の一方の主面側に、絶縁膜を介して電荷転送用電極が後層配列される1の導電型の転送領域が形成され、之に対向し且つ之より上記半導体基体の他方の主面側に上記転送領域との間に他の導電型のベース領域を介して受光領域が形成され、上記ベース領域に所定電圧を印加することにより上記受光領域に蓄積した電荷を上記転送領域に転送し、上記電荷転送用電極に所定のクロック電圧を印加して電荷の転送を行うりようにしたことを特徴とする固体撮像装置。</p> |

Patent Claim of JPA 1975-127646
applied by Yoshiaki Hagiwara at Sony in 1975

Japanese Patent Application JPA 1975-127646

applied by Yoshiaki Hagiwara at Sony on October 23, 1975

File 1975-127646 Filed 1975/10/23
Public 1977-051815 on 1977/04/26

Buried Pinned Photodiode Patent

the NPN Triple Junction type

Dynamic Photo Thyristor

with P-type Charge Carrier (h^+) Buried Channel
CCD/MOS Dynamic Capacitor type Buffer Memory
used for Instant Photo Charge (h^+) Storage
to achieve Global Shutter Function

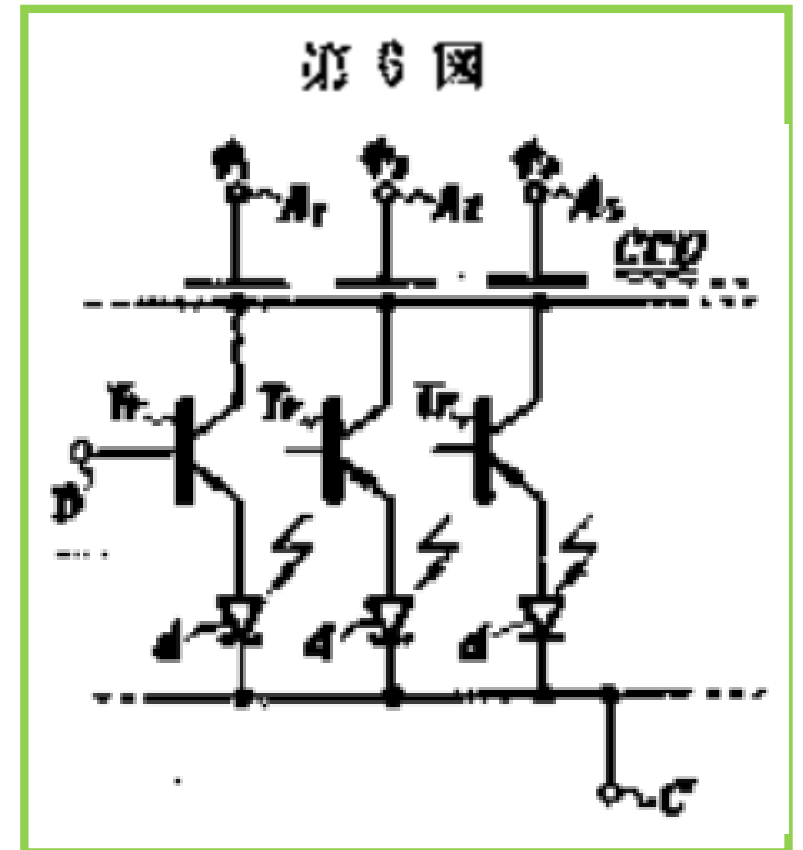
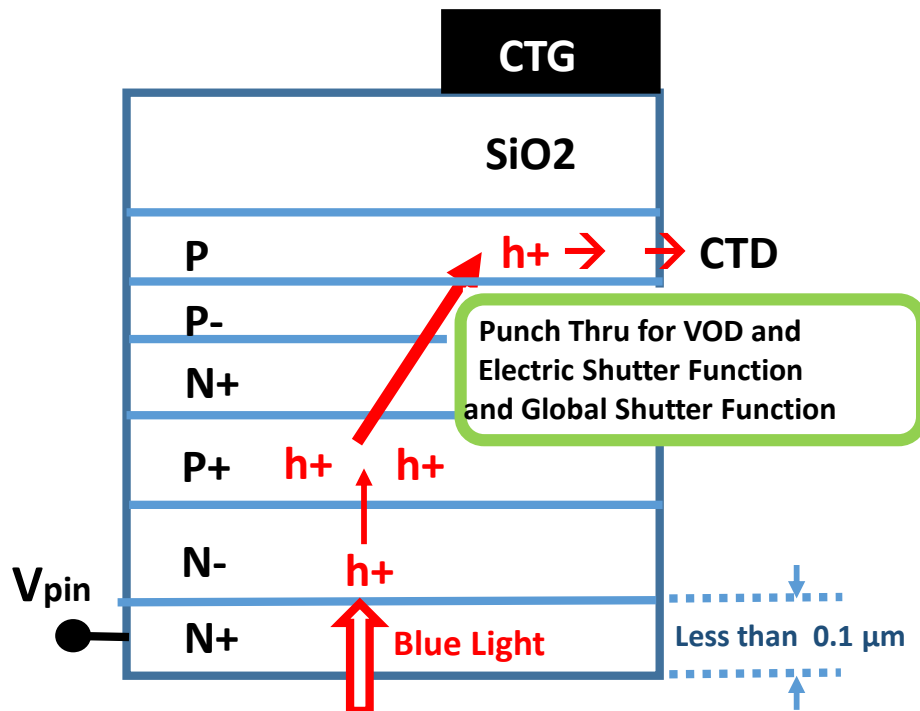

Equivalent Circuit Diagram (Fig. 6)
of Proposed NPN Triple Junction type
Photon Detecting Device (PDD)
drawn in JPA 1975-127646 by Yoshiaki Hagiwara¹³

Japanese Patent Application JPA 1975-127646

applied by Yoshiaki Hagiwara at Sony on October 23, 1975

File 1975-127646 Filed 1975/10/23

Public 1977-051815 on 1977/04/26

Buried Pinned Photodiode Patent

the NPN Triple Junction type

Dynamic Photo Thyristor

with P-type Charge Carrier (h^+) Buried Channel
CCD/MOS Dynamic Capacitor type Buffer Memory
used for Instant Photo Charge (h^+) Storage
to achieve Global Shutter Function

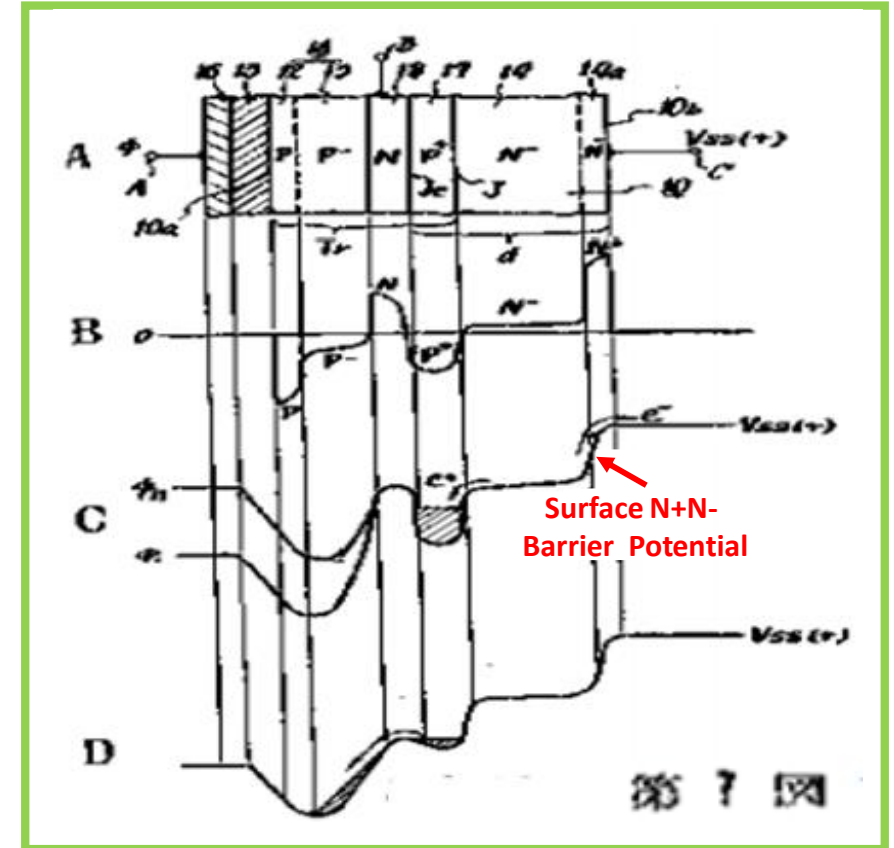
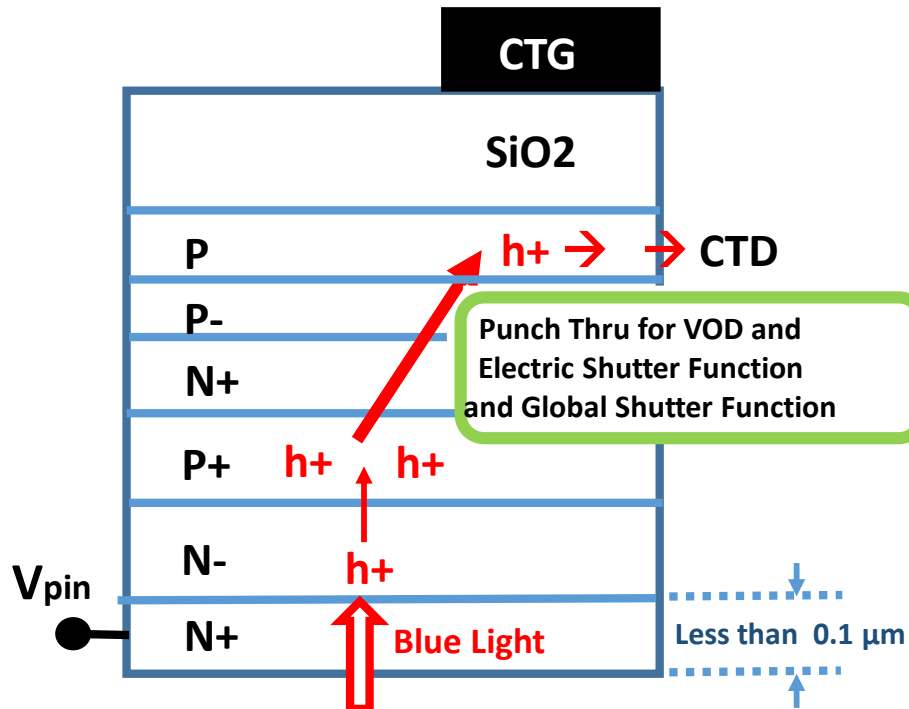

An Example of Device Cross Section (Fig. 7)
of Photon Detecting Device (PDD)
drawn in JPA 1975-127646 by Yoshiaki Hagiwara

Japanese Patent Application JPA 1975-127646

applied by Yoshiaki Hagiwara at Sony on October 23, 1975

File 1975-127646 Filed 1975/10/23
Public 1977-051815 on 1977/04/26

Buried Pinned Photodiode Patent

the NPNP Triple Junction type

Dynamic Photo Thyristor

with P-type Charge Carrier (h^+) Buried Channel

CCD/MOS Dynamic Capacitor type Buffer Memory

used for Instant Photo Charge (h^+) Storage
to achieve Global Shutter Function

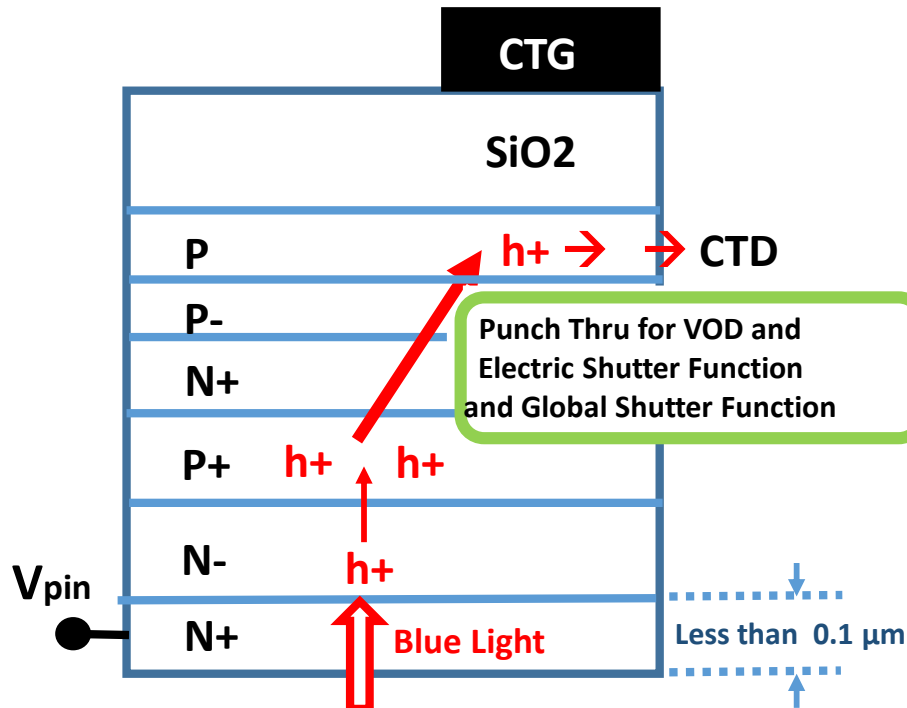

| 明 示 書 | 明 細 書 | 特 許 願 求 書 |
|---------|---|-----------|
| 発明の名称 | 固体撮像装置 | |
| 特許請求の範囲 | <p>半導体基体の一方の主面側に、絶縁膜を介して電荷転送用電極が後層配列される1の導電型の転送領域が形成され、之に対向し且つ之より上記半導体基体の他方の主面側に上記転送領域との間に他の導電型のベース領域を介して受光領域が形成され、上記ベース領域に所定電圧を印加することにより上記受光領域に蓄積した電荷を上記転送領域に転送し、上記電荷転送用電極に所定のクロック電圧を印加して電荷の転送を行うりようにしたことを特徴とする固体撮像装置。</p> | |

Patent Claim of JPA 1975-127646
filed by Yoshiaki Hagiwara at Sony in 1975

Japanese Patent Application JPA 1975-127646

applied by Yoshiaki Hagiwara at Sony on October 23, 1975

Patent Claim in Original Japanese

- 1) 半導体基体(Nsub)の一方の主面側に、
- 2) 絶縁膜(SiO₂)を介して電荷転送装置(CTD)が被着される1の導電型の転送領域(P)が形成され、
- 3) 之(P)に対向して且つ之より上記半導体基体(Nsub)の他方の主面側に上記転送領域(P)との間に他の電導型のベース領域(N)を介して受光領域(P+)が形成され、
- 4) 上記ベース領域(N)に所定の電圧(A)を印加することにより上記受光領域に蓄積した電荷を上記転送領域に転送し、
- 5) 上記電荷転送領域用領域(CTG)に所定のクロック電圧(B)

| 明 細 書 | 明 細 書 |
|---------|--|
| 発明の名称 | 固体撮像装置 |
| 特許請求の範囲 | |
| | 半導体基体の一方の主面側に、絶縁膜を介して電荷転送用電極が被着配列される1の導電型の転送領域が形成され、之に対向し且つ之より上記半導体基体の他方の主面側に上記転送領域との間に他の導電型のベース領域を介して受光領域が形成され、上記ベース領域に所定電圧を印加することにより上記受光領域に蓄積した電荷を上記転送領域に転送し、上記電荷転送用電極に所定のクロック電圧を印加して電荷の転送を行うりようにしたことを特徴とする固体撮像装置。 |

Patent Claim of JPA 1975-127646
filed by Yoshiaki Hagiwara at Sony in 1975

Japanese Patent Application JPA 1975-127646

applied by Yoshiaki Hagiwara at Sony on October 23, 1975

Patent Claim in Original Japanese

- 1) 半導体基体(Nsub)の一方の主面側に、
- 2) 絶縁膜(SiO₂)を介して電荷転送装置(CTD)が被着される1の導電型の転送領域(P)が形成され、
- 3) 之(P)に対向して且つ之より上記半導体基体(Nsub)の他方の主面側に上記転送領域(P)との間に他の電導型のベース領域(N)を介して受光領域(P+)が形成され、
- 4) 上記ベース領域(N)に所定の電圧(A)を印加することにより上記受光領域に蓄積した電荷を上記転送領域に転送し、
- 5) 上記電荷転送領域用領域(CTG(に所定のクロック電圧(B)

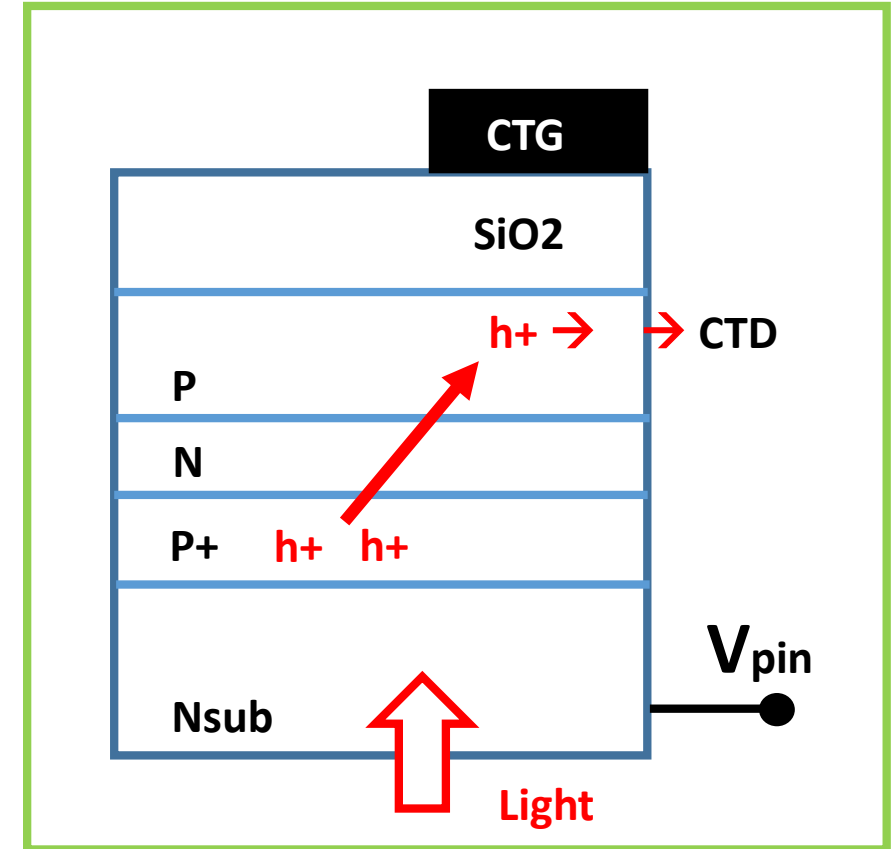

Photon Detecting Device (PDD)
defined in the Patent Claim of
JPA 1975-127646 by Yoshiaki Hagiwara

Japanese Patent Application JPA 1975-127646

applied by Yoshiaki Hagiwara at Sony on October 23, 1975

Patent Claim in Original Japanese

- 1) 半導体基体(Nsub)の一方の主面側に、
- 2) 絶縁膜(SiO₂)を介して電荷転送装置(CTD)が被着される1の導電型の転送領域(P)が形成され、
- 3) 之(P)に対向して且つ之より上記半導体基体(Nsub)の他方の主面側に上記転送領域(P)との間に他の電導型のベース領域(N)を介して受光領域(P+)が形成され、
- 4) 上記ベース領域(N)に所定の電圧(A)を印加することにより上記受光領域に蓄積した電荷を上記転送領域に転送し、
- 5) 上記電荷転送領域用領域(CTG)に所定のクロック電圧(B)

Patent Claim in English Translation

- 1) Along the main surface of a semiconductor substrate (Nsub),
- 2) the charge transfer device (CTD) is placed upon the oxide whereby the type 1 charge transfer region (P) is formed.
- 3) On the opposite side of the region (P), the light detecting region (P+) is formed on the backside substrate (Nsub), with the base region (N) of another type as a bridge.
- 4) By applying a voltage pulse (A) to the base region (N), the charge (h+) stored in the charge detecting region (P+) is transferred to the charge transfer region (P).
- 5) By applying a proper clock voltage (B) to the charge transfer gate (CTG), the charge (h+) is properly transferred further.

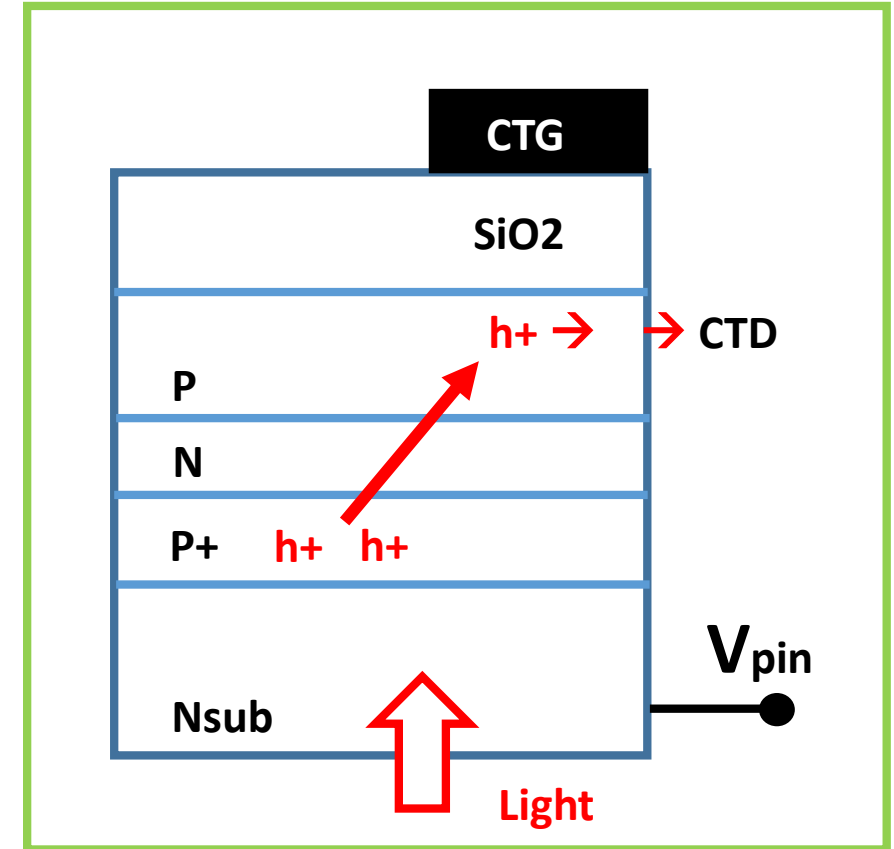

Photon Detecting Device (PDD)
defined in the Patent Claim of
JPA 1975-127646 by Yoshiaki Hagiwara

Japanese Patent Application JPA 1975-127646

applied by Yoshiaki Hagiwara at Sony on October 23, 1975

Patent Claim in Original Japanese

1) 半導体基体(Nsub)の一方の主面側に、

Patent Claim in English Translation

1) Along the main surface of a semiconductor substrate (Nsub),

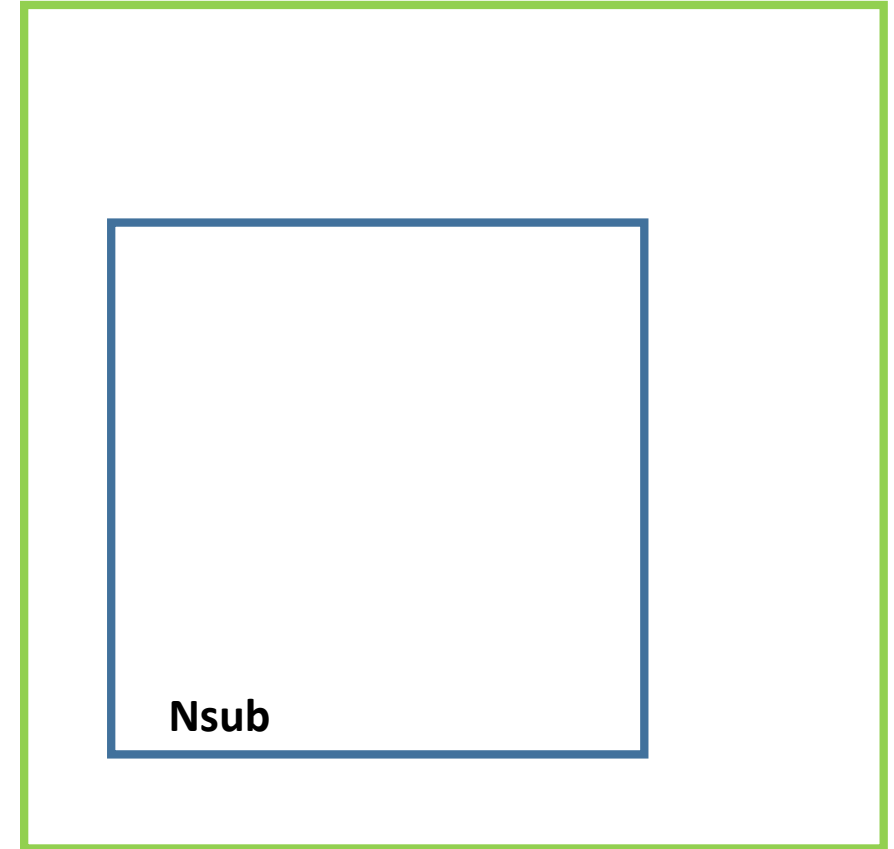

Photon Detecting Device (PDD)
defined in the Patent Claim of
JPA 1975-127646 by Yoshiaki Hagiwara

Japanese Patent Application JPA 1975-127646

applied by Yoshiaki Hagiwara at Sony on October 23, 1975

Patent Claim in Original Japanese

- 1) 半導体基体(Nsub)の一方の主面側に、
- 2) 絶縁膜(SiO₂)を介して電荷転送装置(CTD)が被着される1の導電型の転送領域(P)が形成され、

Patent Claim in English Translation

- 1) Along the main surface of a semiconductor substrate (Nsub),
- 2) the charge transfer device (CTD) is placed upon the oxide whereby the type 1 charge transfer region (P) is formed.

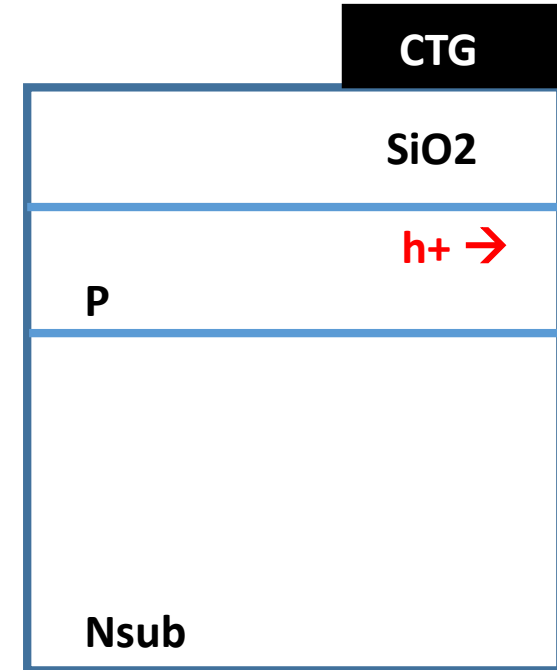

Photon Detecting Device (PDD)
defined in the Patent Claim of
JPA 1975-127646 by Yoshiaki Hagiwara

Japanese Patent Application JPA 1975-127646

applied by Yoshiaki Hagiwara at Sony on October 23, 1975

Patent Claim in Original Japanese

- 1) 半導体基体(Nsub)の一方の主面側に、
- 2) 絶縁膜(SiO₂)を介して電荷転送装置(CTD)が被着される1の導電型の転送領域(P)が形成され、
- 3) 之(P)に対向して且つ之より上記半導体基体(Nsub)の他方の主面側に上記転送領域(P)との間に他の電導型のベース領域(N)を介して受光領域(P+)が形成され、

Patent Claim in English Translation

- 1) Along the main surface of a semiconductor substrate (Nsub),
- 2) the charge transfer device (CTD) is placed upon the oxide whereby the type 1 charge transfer region (P) is formed.
- 3) On the opposite side of the region (P), the light detecting region (P+) is formed on the backside substrate (Nsub), with the base region (N) of another type as a bridge.

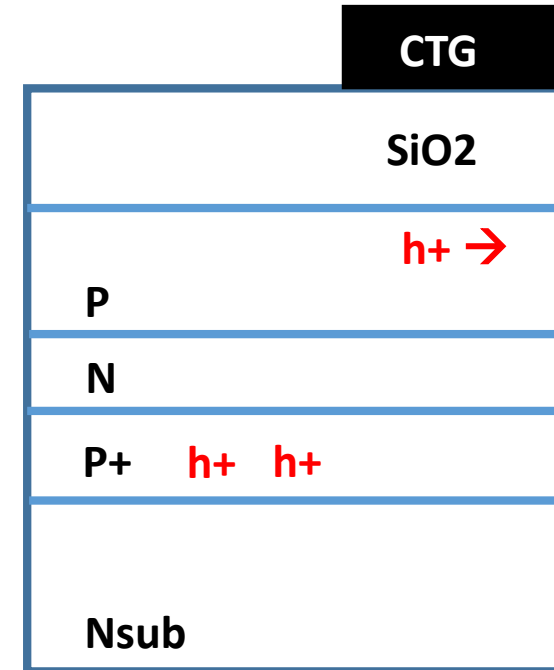

Photon Detecting Device (PDD)
defined in the Patent Claim of
JPA 1975-127646 by Yoshiaki Hagiwara

Japanese Patent Application JPA 1975-127646

applied by Yoshiaki Hagiwara at Sony on October 23, 1975

Patent Claim in Original Japanese

- 1) 半導体基体(Nsub)の一方の主面側に、
- 2) 絶縁膜(SiO₂)を介して電荷転送装置(CTD)が被着される1の導電型の転送領域(P)が形成され、
- 3) 之(P)に対向して且つ之より上記半導体基体(Nsub)の他方の主面側に上記転送領域(P)との間に他の電導型のベース領域(N)を介して受光領域(P+)が形成され、
- 4) 上記ベース領域(N)に所定の電圧(A)を印加することにより上記受光領域に蓄積した電荷を上記転送領域に転送し、

Patent Claim in English Translation

- 1) Along the main surface of a semiconductor substrate (Nsub),
- 2) the charge transfer device (CTD) is placed upon the oxide whereby the type 1 charge transfer region (P) is formed.
- 3) On the opposite side of the region (P), the light detecting region (P+) is formed on the backside substrate (Nsub), with the base region (N) of another type as a bridge.
- 4) By applying a voltage pulse(A) to the base region (N), the charge (h+) stored in the charge detecting region (P+) is transferred to the charge transfer region (P).

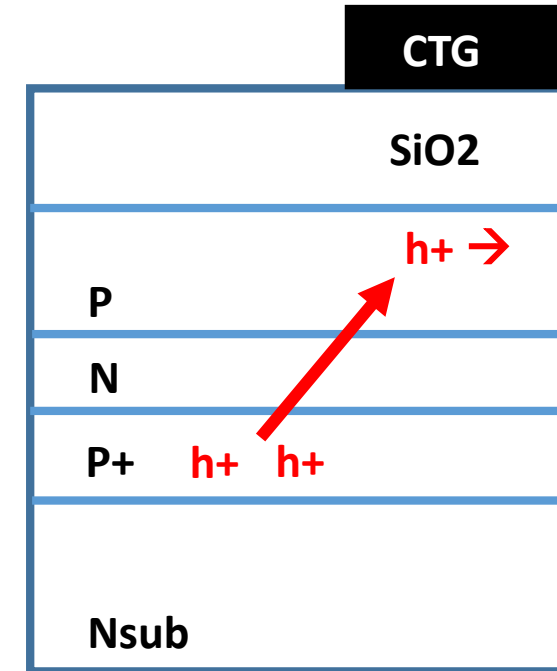

Photon Detecting Device (PDD)
defined in the Patent Claim of
JPA 1975-127646 by Yoshiaki Hagiwara

Japanese Patent Application JPA 1975-127646

applied by Yoshiaki Hagiwara at Sony on October 23, 1975

Patent Claim in Original Japanese

- 1) 半導体基体(Nsub)の一方の主面側に、
- 2) 絶縁膜(SiO₂)を介して電荷転送装置(CTD)が被着される1の導電型の転送領域(P)が形成され、
- 3) 之(P)に対向して且つ之より上記半導体基体(Nsub)の他方の主面側に上記転送領域(P)との間に他の電導型のベース領域(N)を介して受光領域(P+)が形成され、
- 4) 上記ベース領域(N)に所定の電圧(A)を印加することにより上記受光領域に蓄積した電荷を上記転送領域に転送し、
- 5) 上記電荷転送領域用領域(CTG)に所定のクロック電圧(B)

Patent Claim in English Translation

- 1) Along the main surface of a semiconductor substrate (Nsub),
- 2) the charge transfer device (CTD) is placed upon the oxide whereby the type 1 charge transfer region (P) is formed.
- 3) On the opposite side of the region (P), the light detecting region (P+) is formed on the backside substrate (Nsub), with the base region (N) of another type as a bridge.
- 4) By applying a voltage pulse (A) to the base region (N), the charge (h+) stored in the charge detecting region (P+) is transferred to the charge transfer region (P).
- 5) By applying a proper clock voltage (B) to the charge transfer gate (CTG), the charge (h+) is properly transferred further.

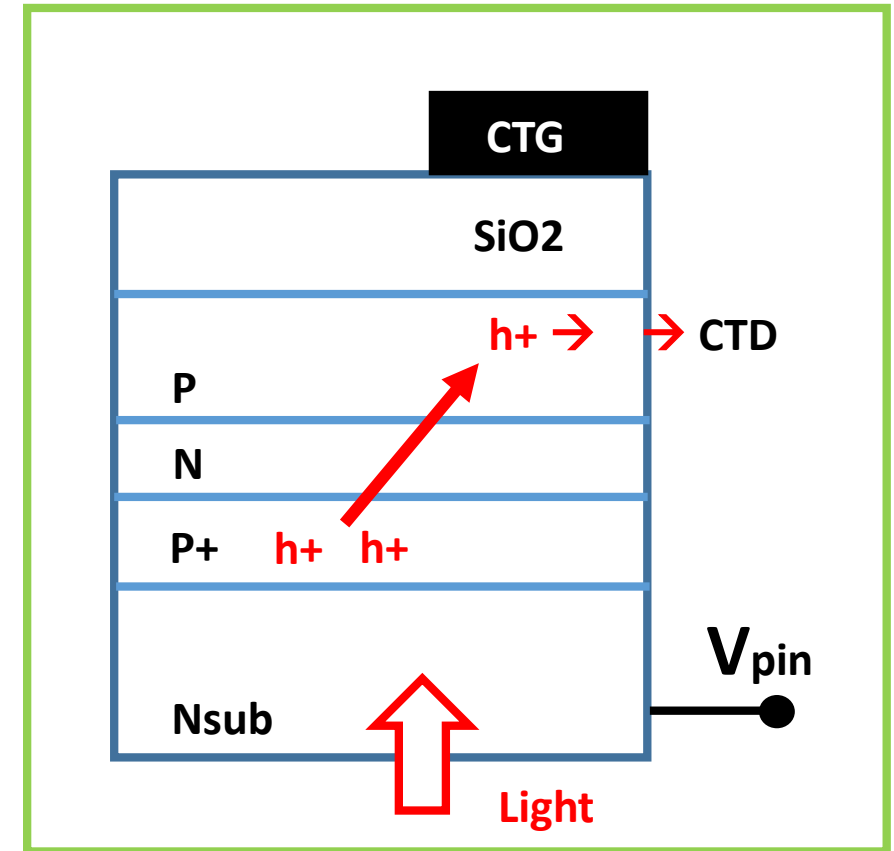

Photon Detecting Device (PDD)
defined in the Patent Claim of
JPA 1975-127646 by Yoshiaki Hagiwara

Japanese Patent Application JPA 1975-127646

applied by Yoshiaki Hagiwara at Sony on October 23, 1975

Patent Claim in Original Japanese

- 1) 半導体基体(Nsub)の一方の主面側に、
- 2) 絶縁膜(SiO₂)を介して電荷転送装置(CTD)が被着される1の導電型の転送領域(P)が形成され、
- 3) 之(P)に対向してかつ之より上記半導体基体(Nsub)の他方の主面側に上記転送領域(P)との間に他の電導型のベース領域(N)を介して受光領域(P+)が形成され、
- 4) 上記ベース領域(N)に所定の電圧(A)を印加することにより上記受光領域に蓄積した電荷を上記転送領域に転送し、
- 5) 上記電荷転送領域用領域(CTG)に所定のクロック電圧(B)

Patent Claim in English Translation

- 1) Along the main surface of a semiconductor substrate (Nsub),
- 2) the charge transfer device (CTD) is placed upon the oxide whereby the type 1 charge transfer region (P) is formed.
- 3) On the opposite side of the region (P), the light detecting region (P+) is formed on the backside substrate (Nsub), with the base region (N) of another type as a bridge.
- 4) By applying a voltage pulse(A) to the base region (N), the charge (h+) stored in the charge detecting region (P+) is transferred to the charge transfer region (P).
- 5) By applying a proper clock voltage (B) to the charge transfer gate (CTG), the charge (h+) is properly transferred further.

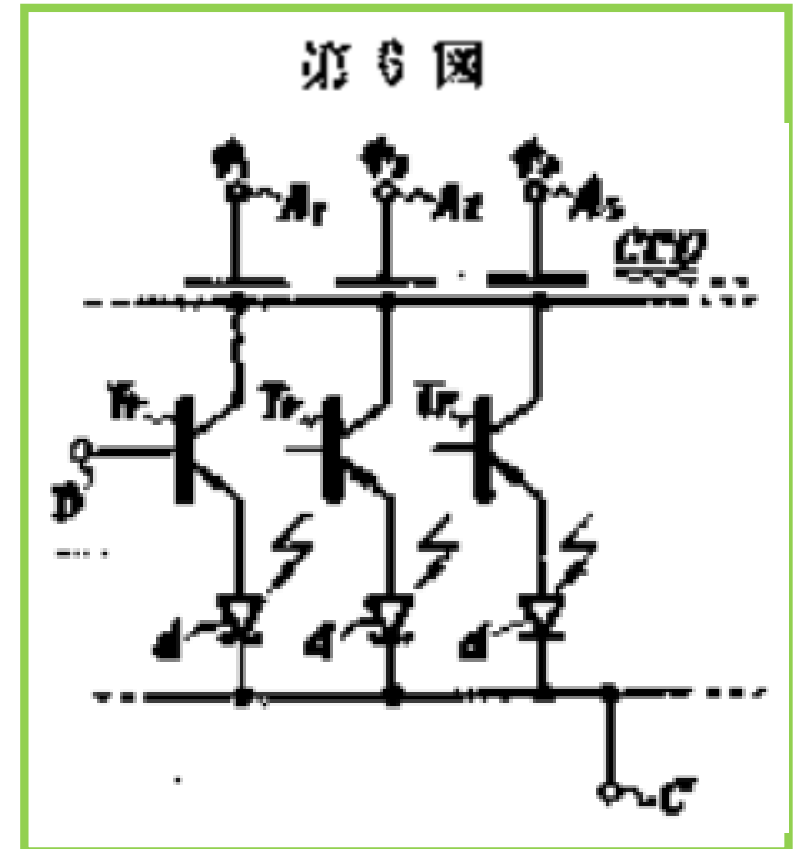

Equivalent Circuit Diagram (Fig. 6)
of Proposed NPN Triple Junction type
Photon Detecting Device (PDD)

drawn in JPA 1975-127646 by Yoshiaki Hagiwara²⁴

Japanese Patent Application JPA 1975-127646

applied by Yoshiaki Hagiwara at Sony on October 23, 1975

Patent Claim in Original Japanese

- 1) 半導体基体(Nsub)の一方の主面側に、
- 2) 絶縁膜(SiO₂)を介して電荷転送装置(CTD)が被着される1の導電型の転送領域(P)が形成され、
- 3) 之(P)に対向して且つ之より上記半導体基体(Nsub)の他方の主面側に上記転送領域(P)との間に他の電導型のベース領域(N)を介して受光領域(P+)が形成され、
- 4) 上記ベース領域(N)に所定の電圧(A)を印加することにより上記受光領域に蓄積した電荷を上記転送領域に転送し、
- 5) 上記電荷転送領域用領域(CTG)に所定のクロック電圧(B)

Patent Claim in English Translation

- 1) Along the main surface of a semiconductor substrate (Nsub),
- 2) the charge transfer device (CTD) is placed upon the oxide whereby the type 1 charge transfer region (P) is formed.
- 3) On the opposite side of the region (P), the light detecting region (P+) is formed on the backside substrate (Nsub), with the base region (N) of another type as a bridge.
- 4) By applying a voltage pulse(A) to the base region (N), the charge (h+) stored in the charge detecting region (P+) is transferred to the charge transfer region (P).
- 5) By applying a proper clock voltage (B) to the charge transfer gate (CTG), the charge (h+) is properly transferred further.

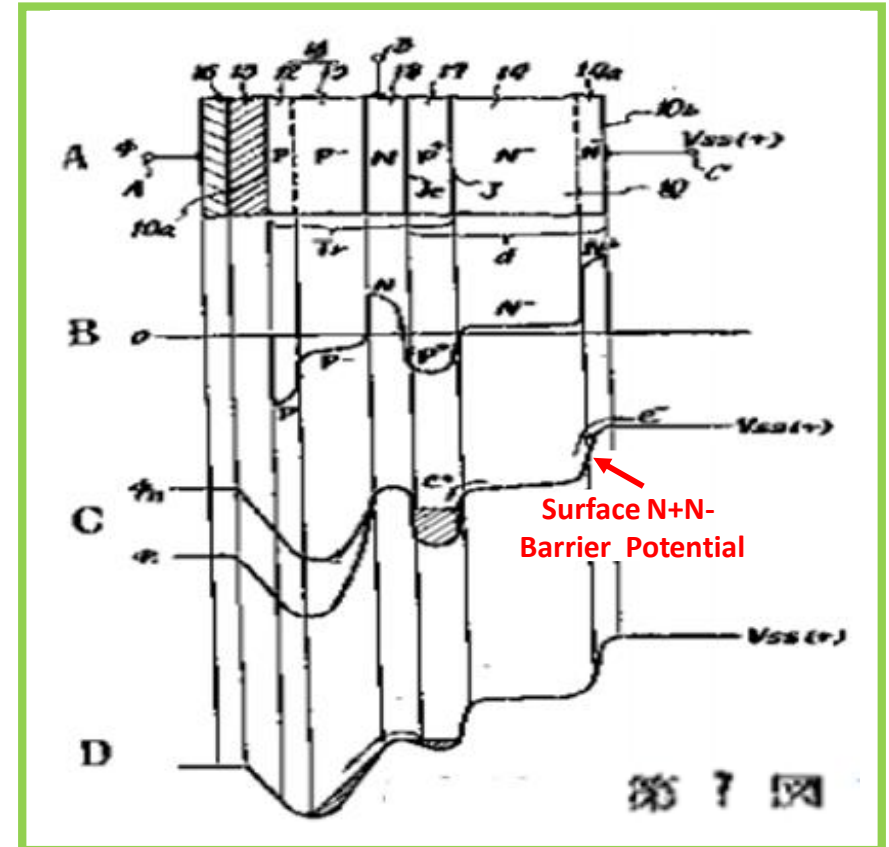

An Example of Device Cross Section (Fig. 7)
of Photon Detecting Device (PDD)
drawn in JPA 1975-127646 by Yoshiaki Hagiwara

Japanese Patent Application JPA 1975-127646

applied by Yoshiaki Hagiwara at Sony on October 23, 1975

Patent Claim in Original Japanese

- 1) 半導体基体(Nsub)の一方の主面側に、
- 2) 絶縁膜(SiO₂)を介して電荷転送装置(CTD)が被着される1の導電型の転送領域(P)が形成され、
- 3) 之(P)に対向して且つ之より上記半導体基体(Nsub)の他方の主面側に上記転送領域(P)との間に他の電導型のベース領域(N)を介して受光領域(P+)が形成され、
- 4) 上記ベース領域(N)に所定の電圧(A)を印加することにより上記受光領域に蓄積した電荷を上記転送領域に転送し、
- 5) 上記電荷転送領域用領域(CTG)に所定のクロック電圧(B)

Patent Claim in English Translation

- 1) Along the main surface of a semiconductor substrate (Nsub),
- 2) the charge transfer device (CTD) is placed upon the oxide whereby the type 1 charge transfer region (P) is formed.
- 3) On the opposite side of the region (P), the light detecting region (P+) is formed on the backside substrate (Nsub), with the base region (N) of another type as a bridge.
- 4) By applying a voltage pulse(A) to the base region (N), the charge (h+) stored in the charge detecting region (P+) is transferred to the charge transfer region (P).
- 5) By applying a proper clock voltage (B) to the charge transfer gate (CTG), the charge (h+) is properly transferred further.

File 1975-127646 Filed 1975/10/23
Public 1977-051815 on 1977/04/26

Buried Pinned Photodiode Patent

the NPNP Triple Junction type
Dynamic Photo Thyristor
with P-type Charge Carrier (h+) Buried Channel
CCD/MOS Dynamic Capacitor type Buffer Memory
used for Instant Photo Charge (h+) Storage
to achieve Global Shutter Function

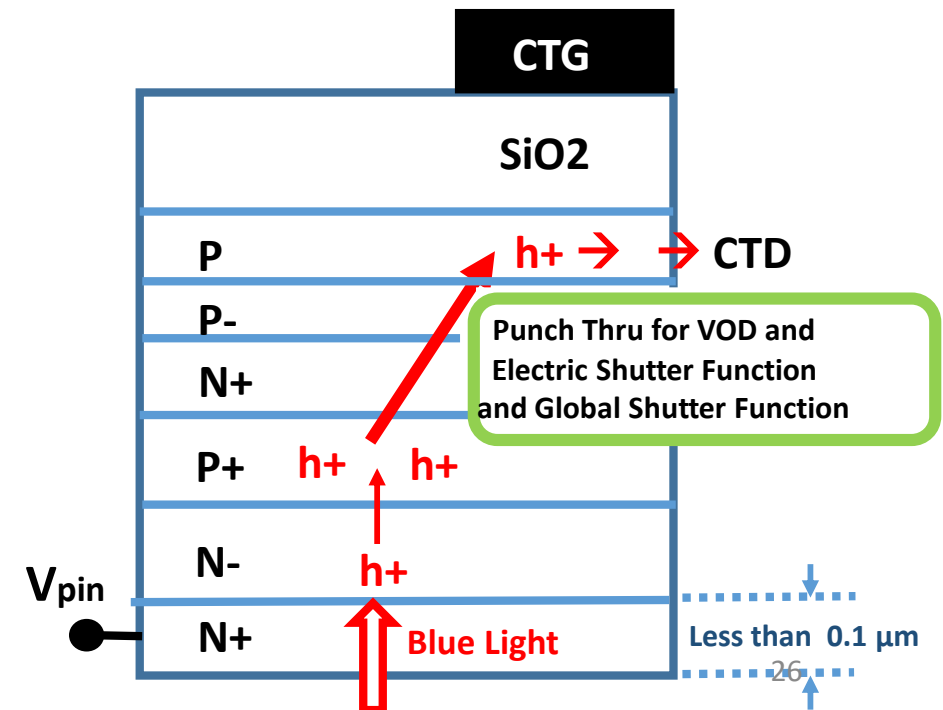

Japanese Patent Application JPA 1975-127647

applied by Yoshiaki Hagiwara at Sony on October 23, 1975

File 1975-127647 Filed 1975/10/23
Public 1977-051816 on 1977/04/26

Buried Pinned Photodiode Patent

the NPN Double Junction type

Dynamic Photo Transistor

with P-type Charge Carrier (h^+) Surface Channel
CCD/MOS Dynamic Capacitor type Buffer Memory
used for Instant Photo Charge (h^+) Storage
to achieve Global Shutter function

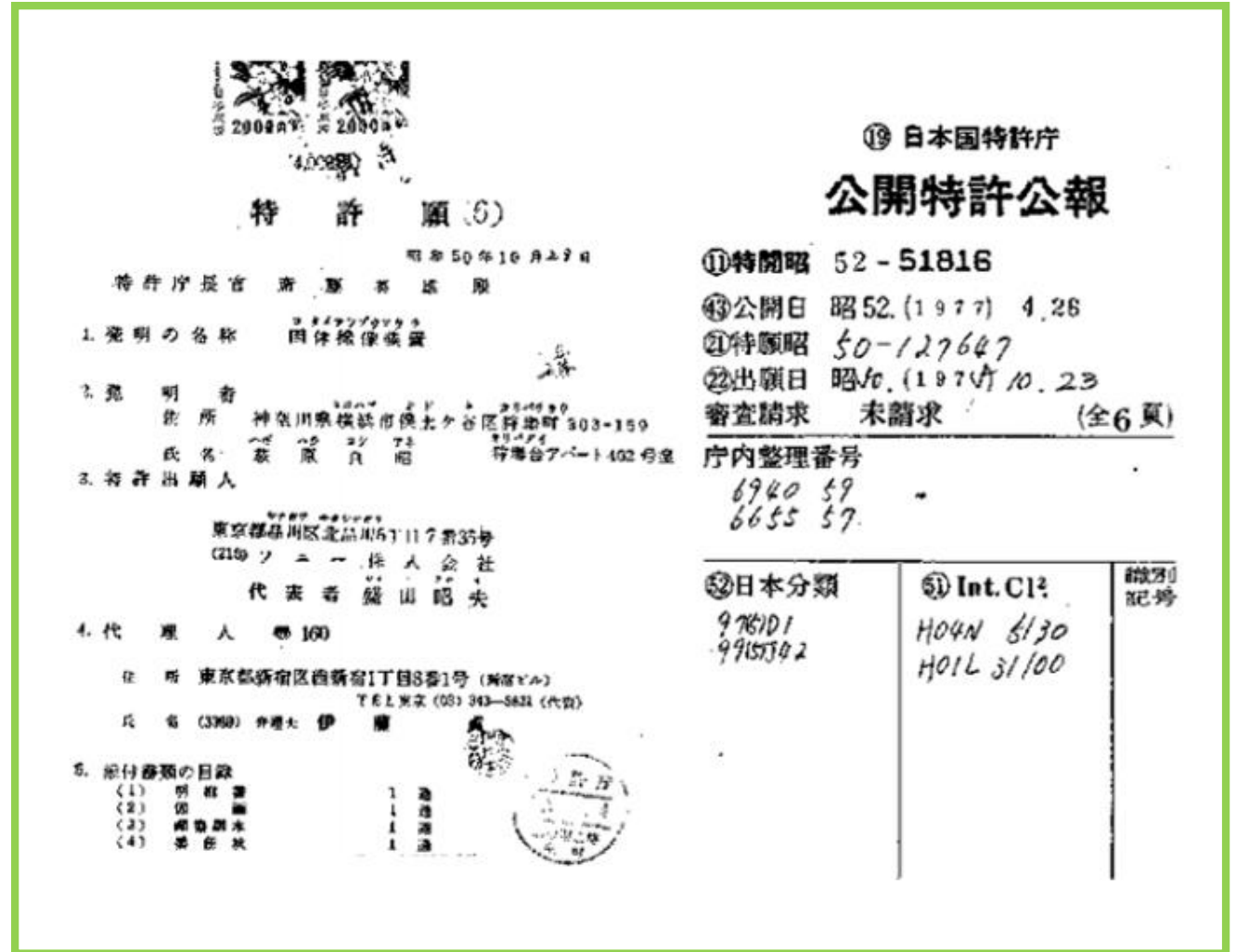
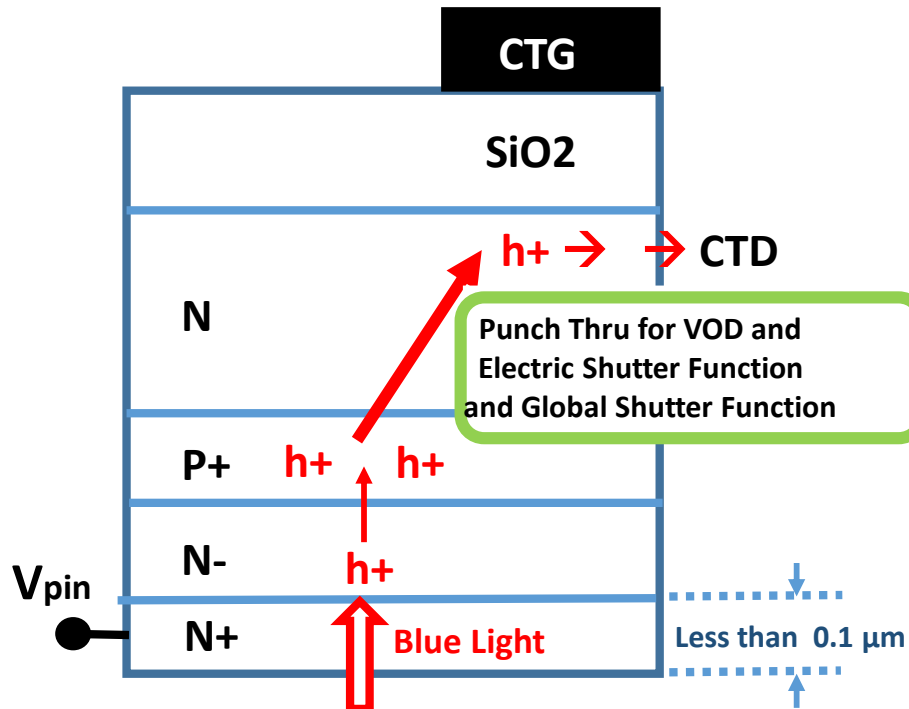

Title Page of JPA 1975-127647
applied by Yoshiaki Hagiwara at Sony in 1975

Japanese Patent Application JPA 1975-127647

applied by Yoshiaki Hagiwara at Sony on October 23, 1975

File 1975-127647 Filed 1975/10/23
Public 1977-051816 on 1977/04/26

Buried Pinned Photodiode Patent

the NPN Double Junction type

Dynamic Photo Transistor

with P-type Charge Carrier (h^+) Surface Channel
CCD/MOS Dynamic Capacitor type Buffer Memory
used for Instant Photo Charge (h^+) Storage
to achieve Global Shutter function

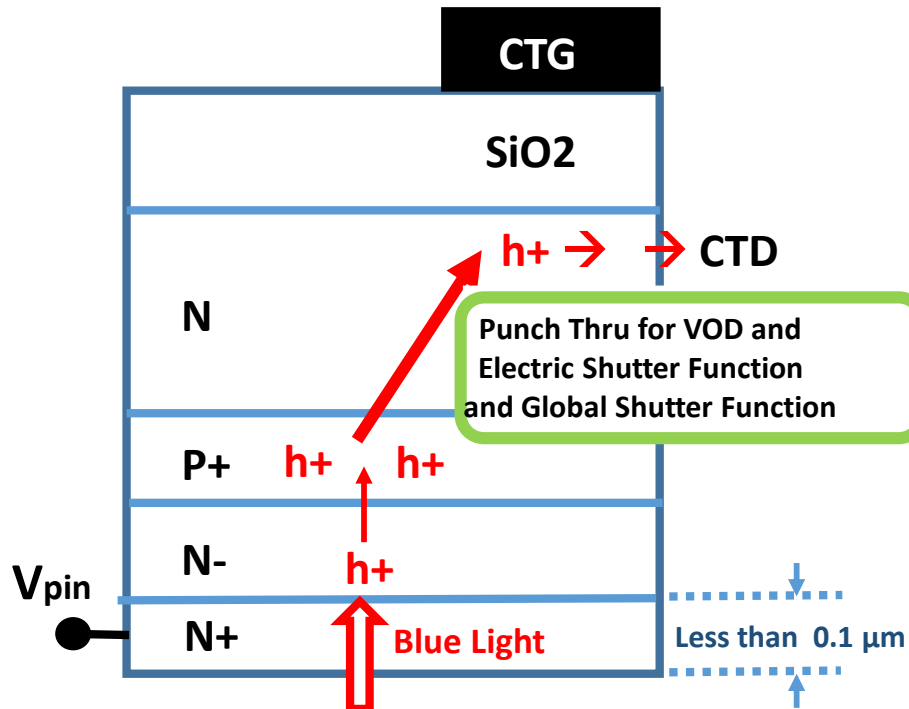

| 明 | 細 | 書 |
|---------|--|---|
| 発明の名称 | 固体撮像装置 | |
| 特許請求の範囲 | <p>半導体基体の一方の主面側に、絶縁膜を介して電荷転送用電極が被着配列される1の導電型の転送領域が形成され、之より上記半導体基体の他方の主面側に上記転送領域に接する他の導電型の領域と被領域に接する1の導電型の領域とより成る受光領域が形成され、上記転送用電極に所要の電圧を印加することにより、上記受光領域に蓄積した電荷を上記転送領域に転送し、上記電荷転送用電極に上記所要の電圧とは異なるクロック電圧を印加して上記基体の上記一方の主面に沿つて電荷の転送を行うようにしたことを特徴とする固体撮像装置。</p> | |

Patent Claim of JPA 1975-127647
applied by Yoshiaki Hagiwara at Sony in 1975

Japanese Patent Application JPA 1975-127647

applied by Yoshiaki Hagiwara at Sony on October 23, 1975

File 1975-127647 Filed 1975/10/23

Public 1977-051816 on 1977/04/26

Buried Pinned Photodiode Patent

the NPN Double Junction type

Dynamic Photo Transistor

with P-type Charge Carrier (h^+) Surface Channel

CCD/MOS Dynamic Capacitor type Buffer Memory

used for Instant Photo Charge (h^+) Storage

to achieve Global Shutter function

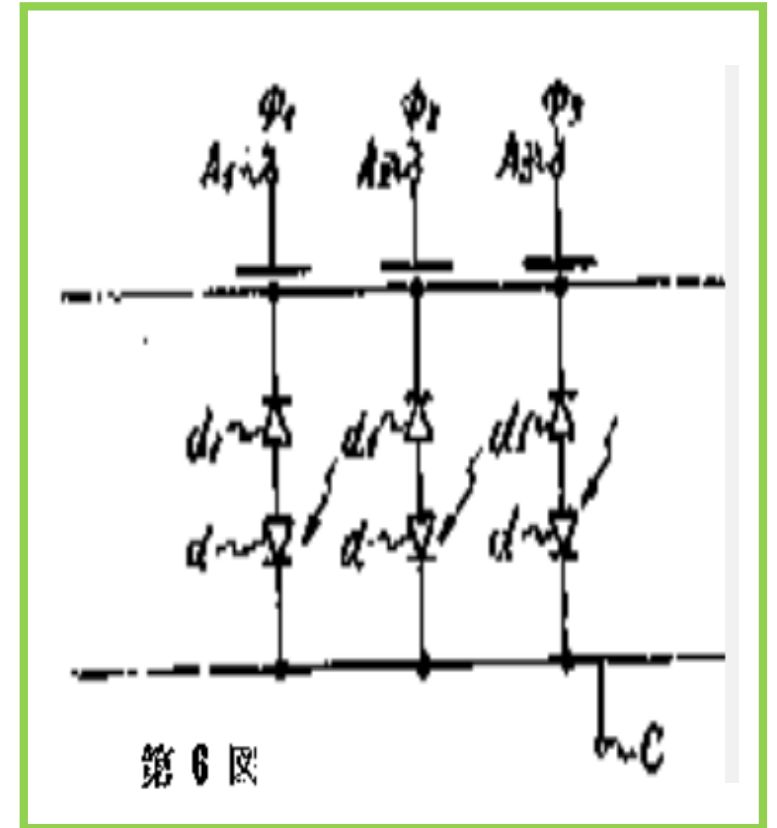
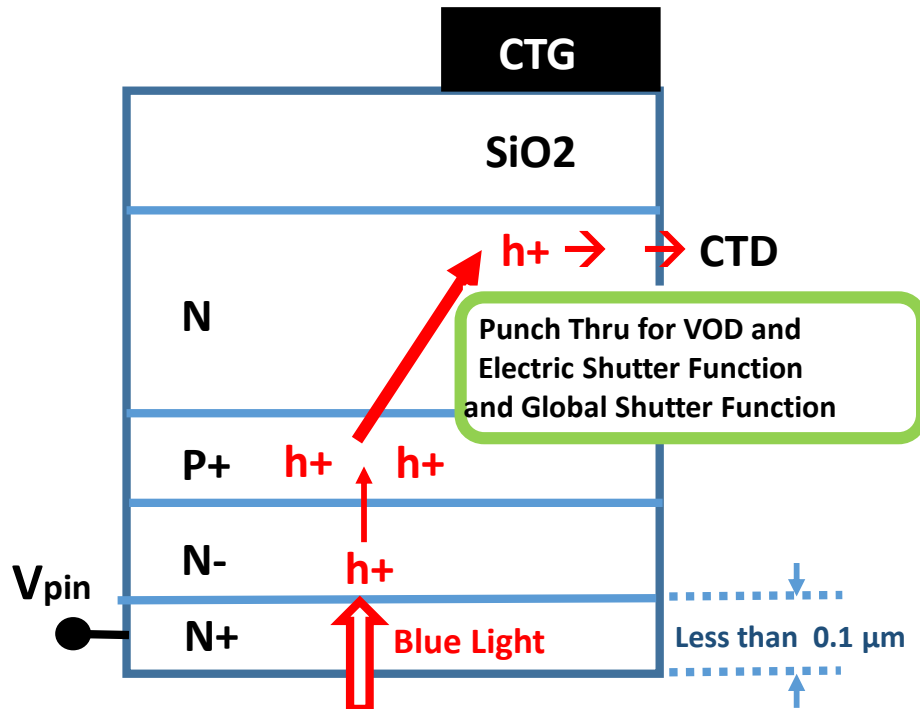

Equivalent Circuit Diagram (Fig. 6)
of Proposed NPN Double Junction type
Photon Detecting Device (PDD)
drawn in JPA 1975-127647 by Yoshiaki Hagiwara

Japanese Patent Application JPA 1975-127647

applied by Yoshiaki Hagiwara at Sony on October 23, 1975

File 1975-127647 Filed 1975/10/23

Public 1977-051816 on 1977/04/26

Buried Pinned Photodiode Patent

the NPN Double Junction type

Dynamic Photo Transistor

with P-type Charge Carrier (h^+) Surface Channel

CCD/MOS Dynamic Capacitor type Buffer Memory

used for Instant Photo Charge (h^+) Storage

to achieve Global Shutter function

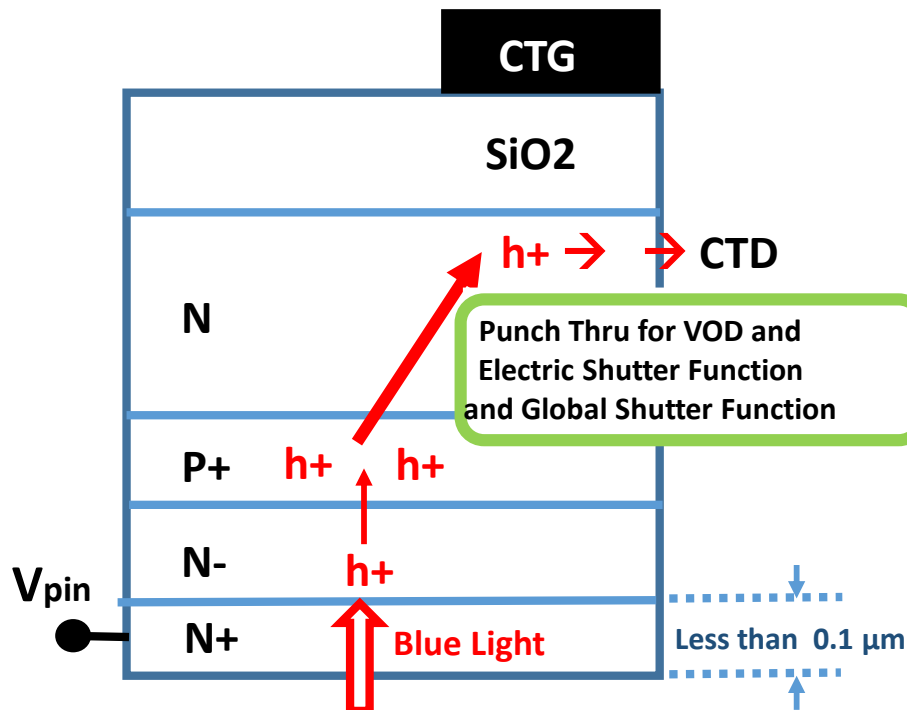

The surface N+N-
Barrier Potential is used
to improve the short wave
the Blue light Sensitivity.

Blue Light cannot
Penetrate more than
0.1 μm in depth
in the silicon crystal.

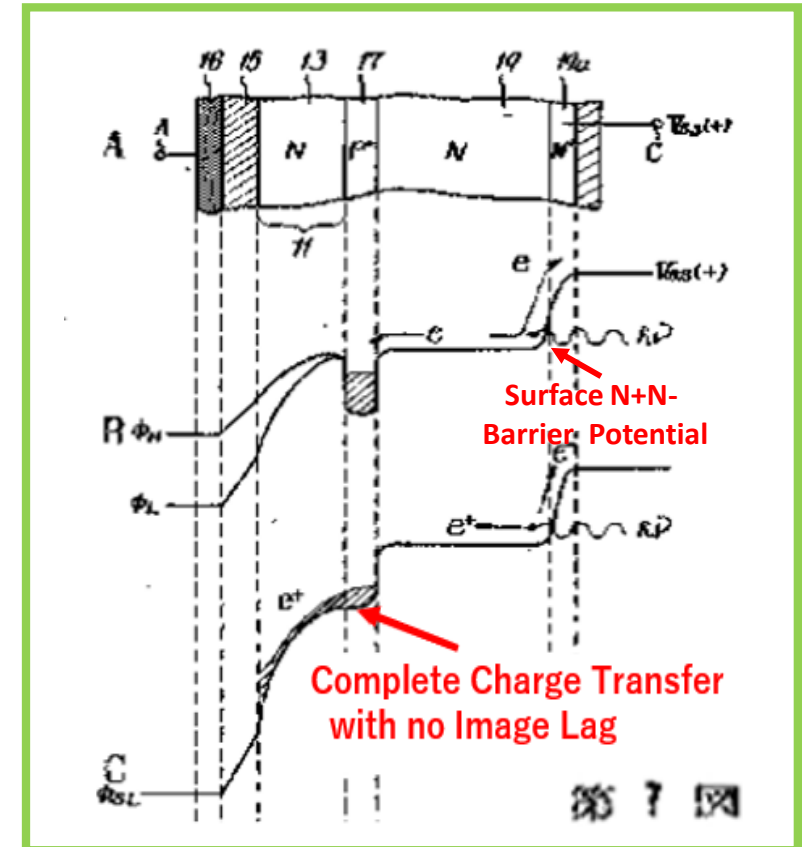

An Example of Device Cross Section (Fig. 7)
of Photon Detecting Device (PDD)
drawn in JPA 1975-127647 by Yoshiaki Hagiwara

Japanese Patent Application JPA 1975-127647

applied by Yoshiaki Hagiwara at Sony on October 23, 1975

Patent Claim in Original Japanese

- 1) 半導体基体(Nsub)の一方の主面側に、
- 2) 絶縁膜(SiO₂)を介して電荷転送用電極(CTG)が被着配列される1の導電型の転送領域(N)が形成され、
- 3) 之(N)より上記半導体基体(Nsub)の他方の主面側に上記転送領域(N)に接する他の導電型の領域と該領域に接する1の導電型の領域(N)とより成る受光領域(P+)が形成され、
- 4) 上記転送用電極(CTG)に所要の電圧(A)を印加することにより、上記受光領域に蓄積した電荷を上記転送領域に転送し、
- 5) 上記電荷転送用電極に上記所要の電圧(A)とは異なるクロック電圧(B)を印加して上記基体の上記一方の主面に沿って電荷の転送を行うようにしたことを特徴とする個体撮像創装置

明 細 書

発明の名称 個体撮像装置

特許請求の範囲

半導体基体の一方の主面側に、絶縁膜を介して電荷転送用電極が被着配列される1の導電型の転送領域が形成され、之より上記半導体基体の他方の主面側に上記転送領域に接する他の導電型の領域と該領域に接する1の導電型の領域とより成る受光領域が形成され、上記転送用電極に所要の電圧を印加することにより、上記受光領域に蓄積した電荷を上記転送領域に転送し、上記電荷転送用電極に上記所要の電圧とは異なるクロック電圧を印加して上記基体の上記一方の主面に沿って電荷の転送を行うようにしたことを特徴とする個体撮像装置。

Patent Claim of JPA 1975-127647

applied by Yoshiaki Hagiwara at Sony in 1975

Japanese Patent Application JPA 1975-127647

applied by Yoshiaki Hagiwara at Sony on October 23, 1975

Patent Claim in Original Japanese

- 1) 半導体基体(Nsub)の一方の主面側に、
- 2) 絶縁膜(SiO₂)を介して電荷転送用電極(CTG)が被着配列される1の導電型の転送領域(N)が形成され、
- 3) 之(N)より上記半導体基体(Nsub)の他方の主面側に上記転送領域(N)に接する他の導電型の領域と該領域に接する1の導電型の領域(N)とより成る受光領域(P+)が形成され、
- 4) 上記転送用電極(CTG)に所要の電圧(A)を印加することにより、上記受光領域に蓄積した電荷を上記転送領域に転送し、
- 5) 上記電荷転送用電極に上記所要の電圧(A)とは異なるクロック電圧(B)を印加して上記基体の上記一方の主面に沿って電荷の転送を行うようにしたことを特徴とする個体撮像創装置

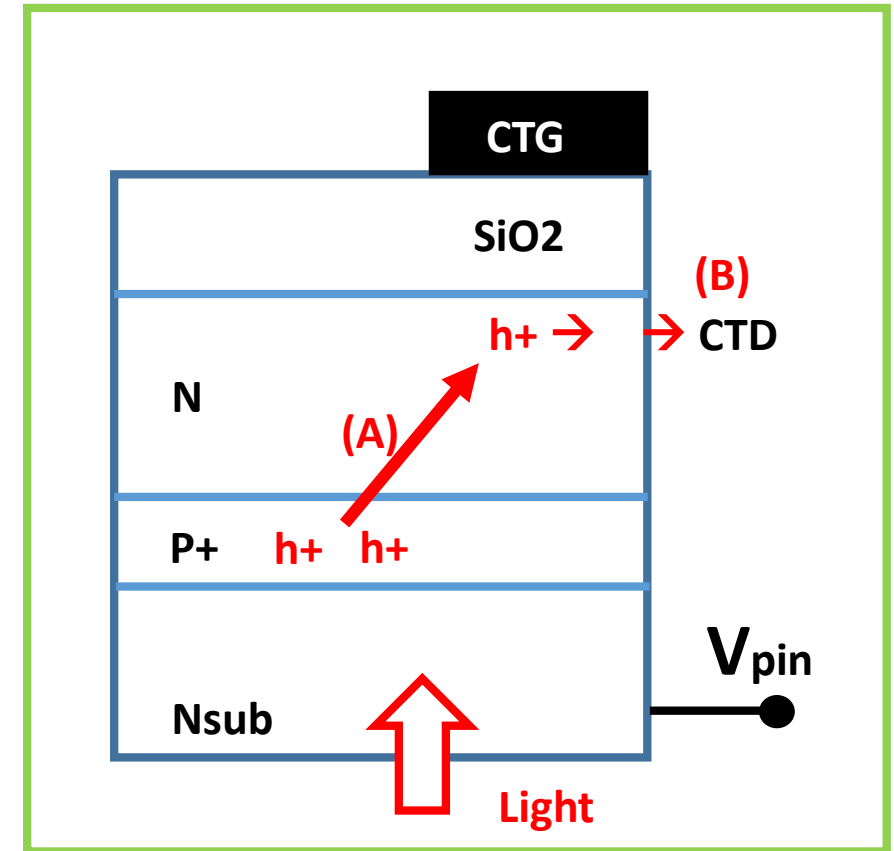

Photon Detecting Device (PDD)
defined in the Patent Claim of
JPA 1975-127647 by Yoshiaki Hagiwara

Japanese Patent Application JPA 1975-127647

applied by Yoshiaki Hagiwara at Sony on October 23, 1975

Patent Claim in Original Japanese

1) 半導体基体(Nsub)の一方の主面側に、

Patent Claim in English Translation

1) Along the main surface of a semiconductor substrate (Nsub),

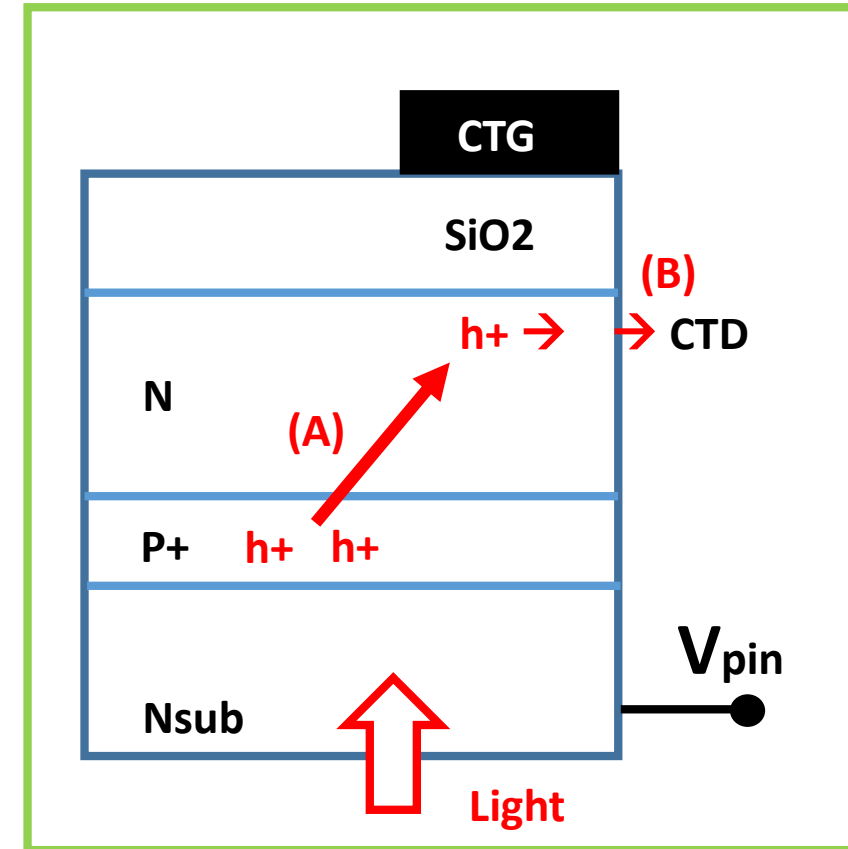

Photon Detecting Device (PDD)
defined in the Patent Claim of
JPA 1975-127647 by Yoshiaki Hagiwara

Japanese Patent Application JPA 1975-127647

applied by Yoshiaki Hagiwara at Sony on October 23, 1975

Patent Claim in Original Japanese

- 1) 半導体基体(Nsub)の一方の主面側に、
- 2) 絶縁膜(SiO₂)を介して電荷転送用電極(CTG)が被着配列される1の導電型の転送領域(N)が形成され、

Patent Claim in English Translation

- 1) Along the main surface of a semiconductor substrate (Nsub),
- 2) the charge transfer gates (CTG) is placed upon the oxide, under which the type 1 charge transfer region (N) is formed.

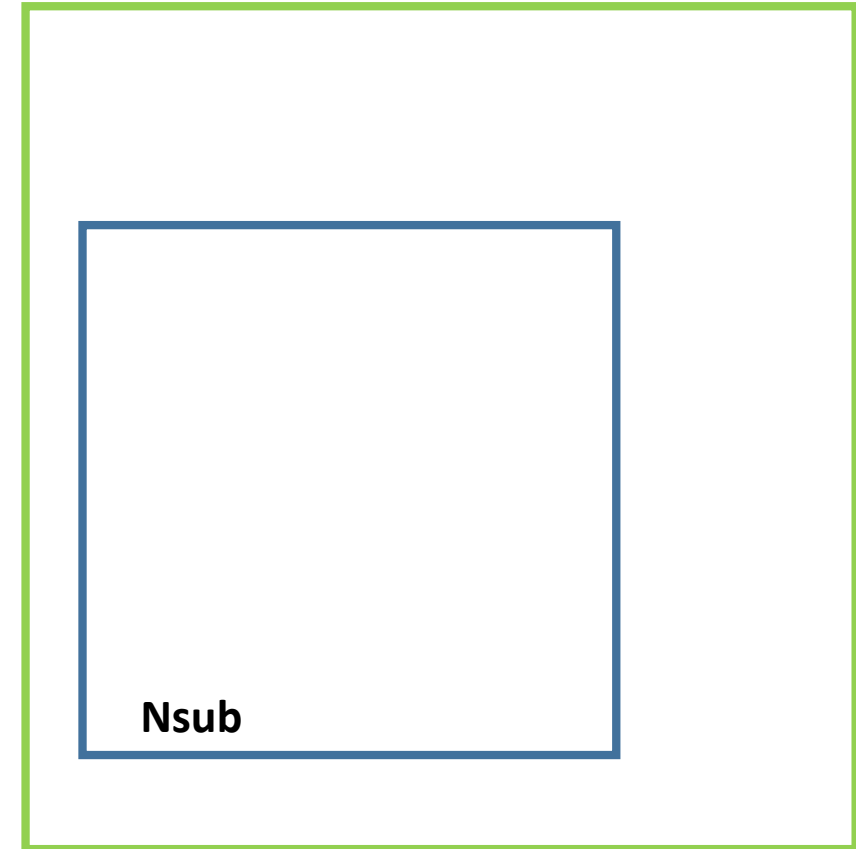

Photon Detecting Device (PDD)
defined in the Patent Claim of
JPA 1975-127647 by Yoshiaki Hagiwara

Japanese Patent Application JPA 1975-127647

applied by Yoshiaki Hagiwara at Sony on October 23, 1975

Patent Claim in Original Japanese

- 1) 半導体基体(Nsub)の一方の主面側に、
- 2) 絶縁膜(SiO₂)を介して電荷転送用電極(CTG)が被着配列される1の導電型の転送領域(N)が形成され、
- 3) 之(N)より上記半導体基体(Nsub)の他方の主面側に上記転送領域(N)に接する他の導電型の領域と該領域に接する1の導電型の領域(N)とより成る受光領域(P+)が形成され、

Patent Claim in English Translation

- 1) Along the main surface of a semiconductor substrate (Nsub),
- 2) the charge transfer gates (CTG) is placed upon the oxide, under which the type 1 charge transfer region (N) is formed.
- 3) The light detecting region (P+) is formed in the backside of the substrate which is closely placed with both the surface charge transfer region (N) and the back side surface of the substrate (Nsub).

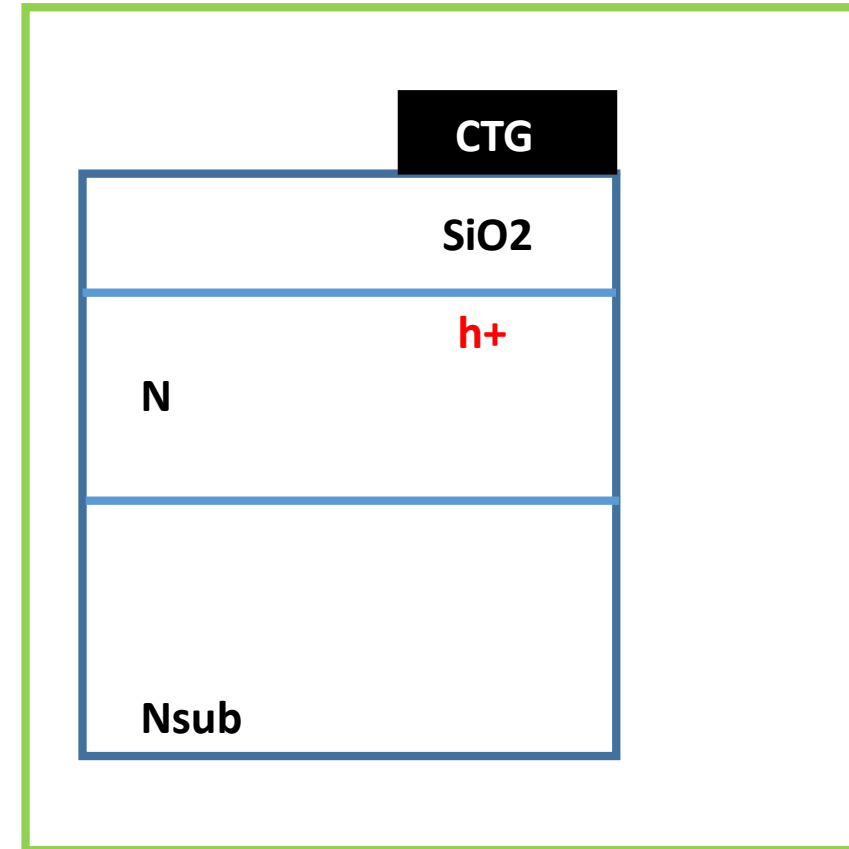

Photon Detecting Device (PDD)
defined in the Patent Claim of
JPA 1975-127647 by Yoshiaki Hagiwara

Japanese Patent Application JPA 1975-127647

applied by Yoshiaki Hagiwara at Sony on October 23, 1975

Patent Claim in Original Japanese

- 1) 半導体基体(Nsub)の一方の主面側に、
- 2) 絶縁膜(SiO₂)を介して電荷転送用電極(CTG)が被着配列される1の導電型の転送領域(N)が形成され、
- 3) 之(N)より上記半導体基体(Nsub)の他方の主面側に上記転送領域(N)に接する他の導電型の領域と該領域に接する1の導電型の領域(N)とより成る受光領域(P+)が形成され、
- 4) 上記転送用電極(CTG)に所要の電圧(A)を印加することにより、上記受光領域に蓄積した電荷を上記転送領域に転送し、

Patent Claim in English Translation

- 1) Along the main surface of a semiconductor substrate (Nsub),
- 2) the charge transfer gates (CTG) is placed upon the oxide, under which the type 1 charge transfer region (N) is formed.
- 3) The light detecting region (P+) is formed in the backside of the substrate which is closely placed with both the surface charge transfer region (N) and the back side surface of the substrate (Nsub).
- 4) By applying a voltage pulse(A) to the Charge Transfer Gate (CTG) the charge (h+) stored in the charge detecting region (P+) is transferred to the surface charge transfer region (N).

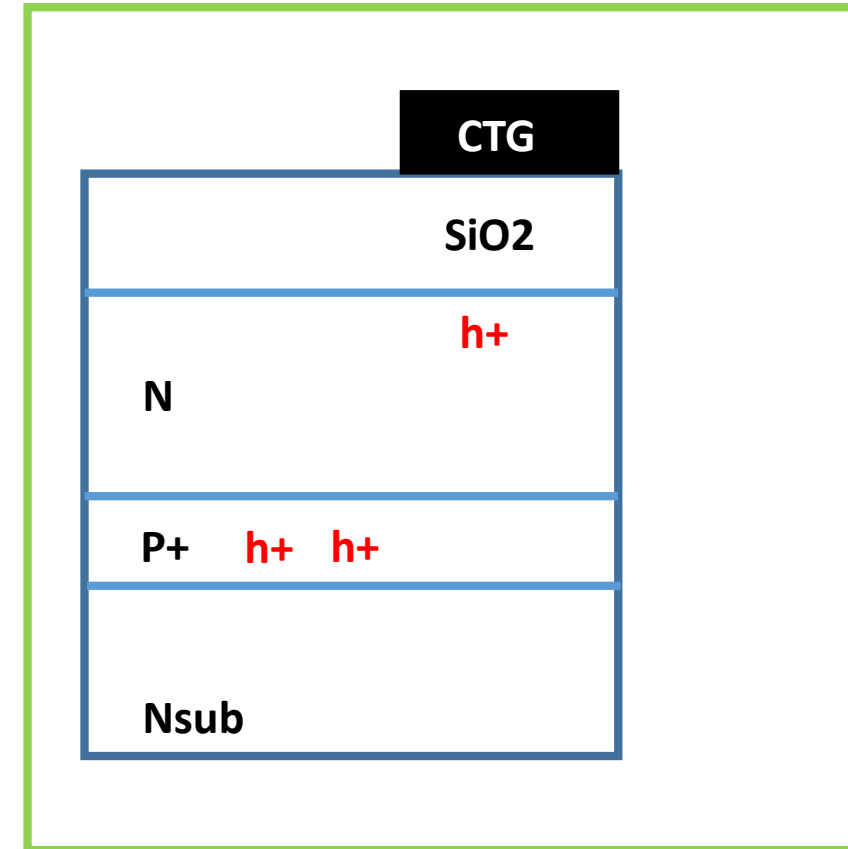

Photon Detecting Device (PDD)
defined in the Patent Claim of
JPA 1975-127647 by Yoshiaki Hagiwara

Japanese Patent Application JPA 1975-127647

applied by Yoshiaki Hagiwara at Sony on October 23, 1975

Patent Claim in Original Japanese

- 1) 半導体基体(Nsub)の一方の主面側に、
- 2) 絶縁膜(SiO₂)を介して電荷転送用電極(CTG)が被着配列される1の導電型の転送領域(N)が形成され、
- 3) 之(N)より上記半導体基体(Nsub)の他方の主面側に上記転送領域(N)に接する他の導電型の領域と該領域に接する1の導電型の領域(N)とより成る受光領域(P+)が形成され、
- 4) 上記転送用電極(CTG)に所要の電圧(A)を印加することにより、上記受光領域に蓄積した電荷を上記転送領域に転送し、
- 5) 上記電荷転送用電極に上記所要の電圧(A)とは異なるクロック電圧(B)を印加して上記基体の上記一方の主面に沿って電荷の転送を行うようにしたことを特徴とする個体撮像創装置

Patent Claim in English Translation

- 1) Along the main surface of a semiconductor substrate (Nsub),
- 2) the charge transfer gates (CTG) is placed upon the oxide, under which the type 1 charge transfer region (N) is formed.
- 3) The light detecting region (P+) is formed in the backside of the substrate which is closely placed with both the surface charge transfer region (N) and the back side surface of the substrate (Nsub).
- 4) By applying a voltage pulse(A) to the Charge Transfer Gate (CTG) the charge (h+) stored in the charge detecting region (P+) is transferred to the surface charge transfer region (N).
- 5) By applying a another deferent clock voltage (B) to the charge transfer gate (CTG), the charge (h+) is transferred further along the main surface of the substrate.

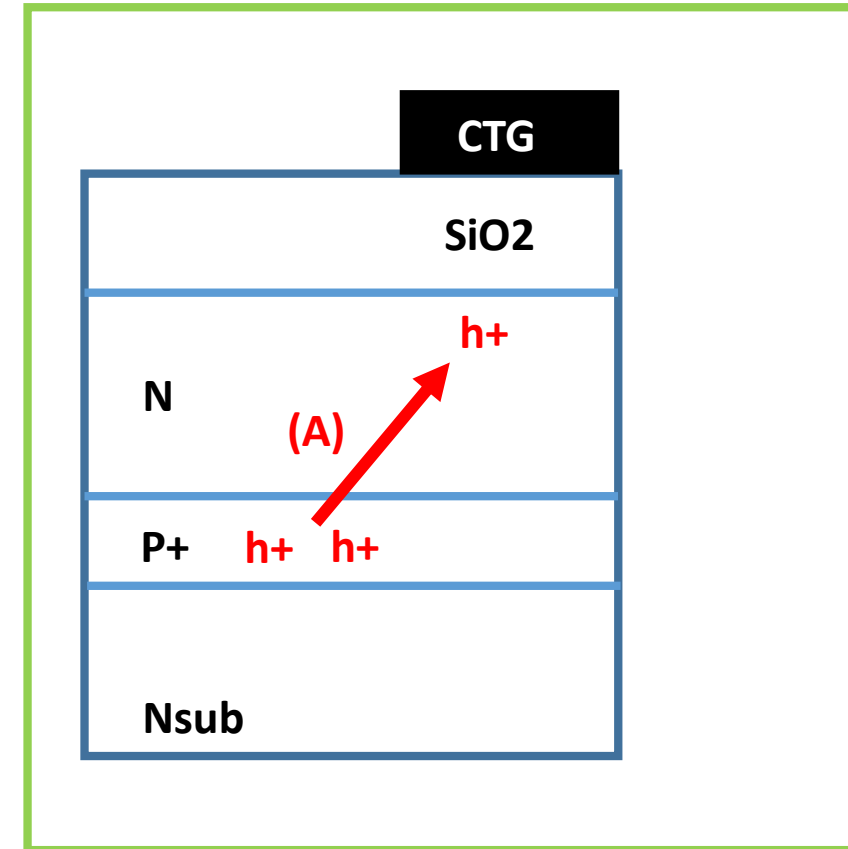

Photon Detecting Device (PDD)
defined in the Patent Claim of
JPA 1975-127647 by Yoshiaki Hagiwara

Japanese Patent Application JPA 1975-127647

applied by Yoshiaki Hagiwara at Sony on October 23, 1975

Patent Claim in Original Japanese

- 1) 半導体基体(Nsub)の一方の主面側に、
- 2) 絶縁膜(SiO₂)を介して電荷転送用電極(CTG)が被着配列される1の導電型の転送領域(N)が形成され、
- 3) 之(N)より上記半導体基体(Nsub)の他方の主面側に上記転送領域(N)に接する他の導電型の領域と該領域に接する1の導電型の領域(N)とより成る受光領域(P+)が形成され、
- 4) 上記転送用電極(CTG)に所要の電圧(A)を印加することにより、上記受光領域に蓄積した電荷を上記転送領域に転送し、
- 5) 上記電荷転送用電極に上記所要の電圧(A)とは異なるクロック電圧(B)を印加して上記基体の上記一方の主面に沿って電荷の転送を行うようにしたことを特徴とする個体撮像創装置

Patent Claim in English Translation

- 1) Along the main surface of a semiconductor substrate (Nsub),
- 2) the charge transfer gates (CTG) is placed upon the oxide, under which the type 1 charge transfer region (N) is formed.
- 3) The light detecting region (P+) is formed in the backside of the substrate which is closely placed with both the surface charge transfer region (N) and the back side surface of the substrate (Nsub).
- 4) By applying a voltage pulse(A) to the Charge Transfer Gate (CTG) the charge (h+) stored in the charge detecting region (P+) is transferred to the surface charge transfer region (N).
- 5) By applying a another deferent clock voltage (B) to the charge transfer gate (CTG), the charge (h+) is transferred further along the main surface of the substrate.

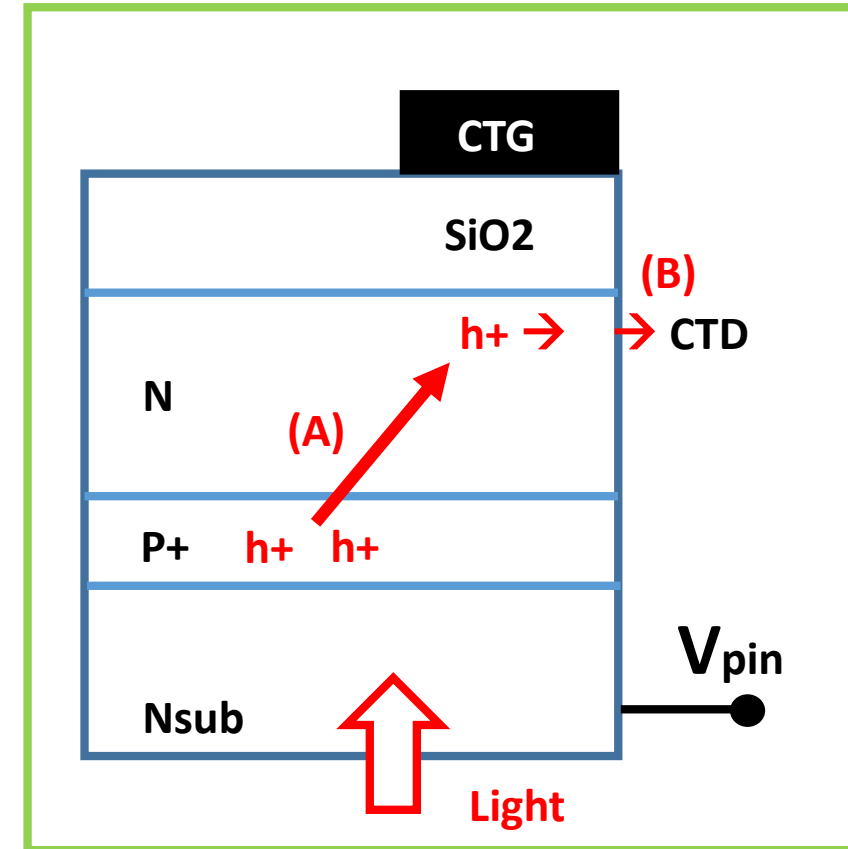

Photon Detecting Device (PDD)
defined in the Patent Claim of
JPA 1975-127647 by Yoshiaki Hagiwara

Japanese Patent Application JPA 1975-127647

applied by Yoshiaki Hagiwara at Sony on October 23, 1975

Patent Claim in Original Japanese

- 1) 半導体基体(Nsub)の一方の主面側に、
- 2) 絶縁膜(SiO₂)を介して電荷転送用電極(CTG)が被着配列される1の導電型の転送領域(N)が形成され、
- 3) 之(N)より上記半導体基体(Nsub)の他方の主面側に上記転送領域(N)に接する他の導電型の領域と該領域に接する1の導電型の領域(N)とより成る受光領域(P+)が形成され、
- 4) 上記転送用電極(CTG)に所要の電圧(A)を印加することにより、上記受光領域に蓄積した電荷を上記転送領域に転送し、
- 5) 上記電荷転送用電極に上記所要の電圧(A)とは異なるクロック電圧(B)を印加して上記基体の上記一方の主面に沿って電荷の転送を行うようにしたことを特徴とする個体撮像創装置

Patent Claim in English Translation

- 1) Along the main surface of a semiconductor substrate (Nsub),
- 2) the charge transfer gates (CTG) is placed upon the oxide, under which the type 1 charge transfer region (N) is formed.
- 3) The light detecting region (P+) is formed in the backside of the substrate which is closely placed with both the surface charge transfer region (N) and the back side surface of the substrate (Nsub).
- 4) By applying a voltage pulse(A) to the Charge Transfer Gate (CTG) the charge (h+) stored in the charge detecting region (P+) is transferred to the surface charge transfer region (N).
- 5) By applying a another deferent clock voltage (B) to the charge transfer gate (CTG), the charge (h+) is transferred further along the main surface of the substrate.

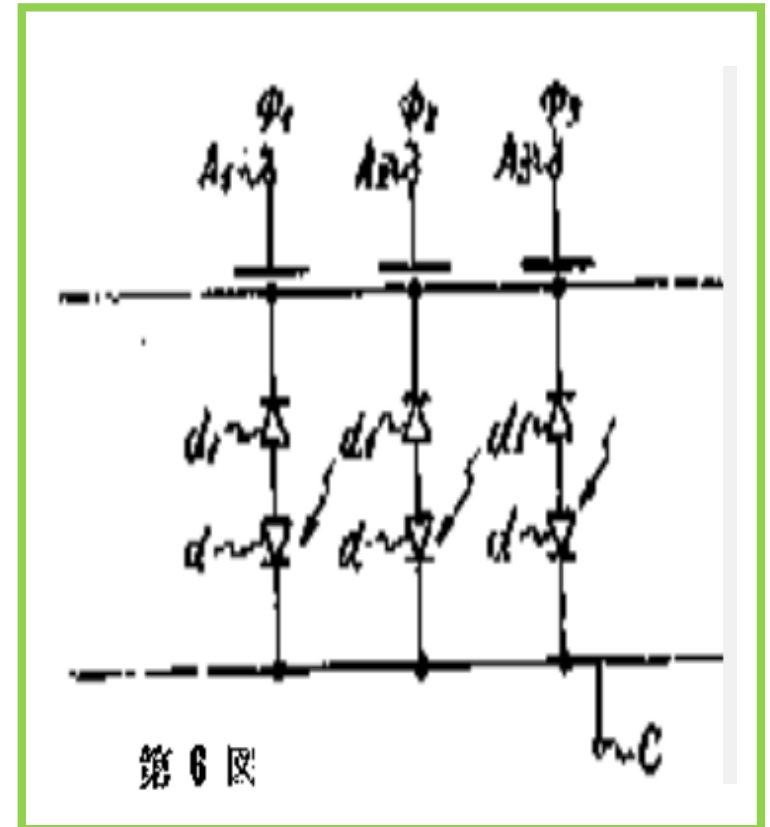

Equivalent Circuit Diagram (Fig. 6)
of Proposed NPN Double Junction type
Photon Detecting Device (PDD)
drawn in JPA 1975-127647 by Yoshiaki Hagiwara

Japanese Patent Application JPA 1975-127647

applied by Yoshiaki Hagiwara at Sony on October 23, 1975

Patent Claim in Original Japanese

- 1) 半導体基体(Nsub)の一方の主面側に、
- 2) 絶縁膜(SiO₂)を介して電荷転送用電極(CTG)が被着配列される1の導電型の転送領域(N)が形成され、
- 3) 之(N)より上記半導体基体(Nsub)の他方の主面側に上記転送領域(N)に接する他の導電型の領域と該領域に接する1の導電型の領域(N)とより成る受光領域(P+)が形成され、
- 4) 上記転送用電極(CTG)に所要の電圧(A)を印加することにより、上記受光領域に蓄積した電荷を上記転送領域に転送し、
- 5) 上記電荷転送用電極に上記所要の電圧(A)とは異なるクロック電圧(B)を印加して上記基体の上記一方の主面に沿って電荷の転送を行うようにしたことを特徴とする個体撮像創装置

Patent Claim in English Translation

- 1) Along the main surface of a semiconductor substrate (Nsub),
- 2) the charge transfer gates (CTG) is placed upon the oxide, under which the type 1 charge transfer region (N) is formed.
- 3) The light detecting region (P+) is formed in the backside of the substrate which is closely placed with both the surface charge transfer region (N) and the back side surface of the substrate (Nsub).
- 4) By applying a voltage pulse(A) to the Charge Transfer Gate (CTG) the charge (h+) stored in the charge detecting region (P+) is transferred to the surface charge transfer region (N).
- 5) By applying a another deferent clock voltage (B) to the charge transfer gate (CTG), the charge (h+) is transferred further along the main surface of the substrate.

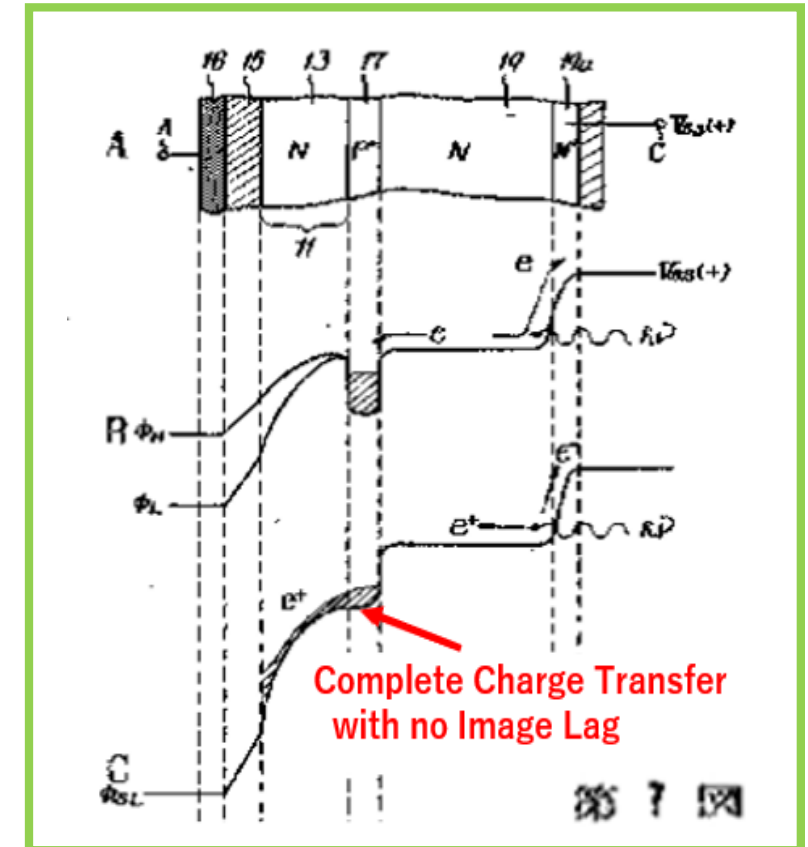

An Example of Device Cross Section (Fig. 7)
of Photon Detecting Device (PDD)
drawn in JPA 1975-127647 by Yoshiaki Hagiwara

Japanese Patent Application JPA 1975-127647

applied by Yoshiaki Hagiwara at Sony on October 23, 1975

Patent Claim in Original Japanese

- 1) 半導体基体(Nsub)の一方の主面側に、
- 2) 絶縁膜(SiO₂)を介して電荷転送用電極(CTG)が被着配列される1の導電型の転送領域(N)が形成され、
- 3) 之(N)より上記半導体基体(Nsub)の他方の主面側に上記転送領域(N)に接する他の導電型の領域と該領域に接する1の導電型の領域(N)とより成る受光領域(P+)が形成され、
- 4) 上記転送用電極(CTG)に所要の電圧(A)を印加することにより、上記受光領域に蓄積した電荷を上記転送領域に転送し、
- 5) 上記電荷転送用電極に上記所要の電圧(A)とは異なるクロック電圧(B)を印加して上記基体の上記一方の主面に沿って電荷の転送を行うようにしたことを特徴とする個体撮像創装置

Patent Claim in English Translation

- 1) Along the main surface of a semiconductor substrate (Nsub),
- 2) the charge transfer gates (CTG) is placed upon the oxide, under which the type 1 charge transfer region (N) is formed.
- 3) The light detecting region (P+) is formed in the backside of the substrate which is closely placed with both the surface charge transfer region (N) and the back side surface of the substrate (Nsub).
- 4) By applying a voltage pulse(A) to the Charge Transfer Gate (CTG) the charge (h+) stored in the charge detecting region (P+) is transferred to the surface charge transfer region (N).
- 5) By applying a another deferent clock voltage (B) to the charge transfer gate (CTG), the charge (h+) is transferred further along the main surface of the substrate.

File 1975-127647 Filed 1975/10/23
Public 1977-051816 on 1977/04/26

Buried Pinned Photodiode Patent

the NPN Double Junction type
Dynamic Photo Transistor

with P-type Charge Carrier (h+) Surface Channel
CCD/MOS Dynamic Capacitor type Buffer Memory
used for Instant Photo Charge (h+) Storage
to achieve Global Shutter function

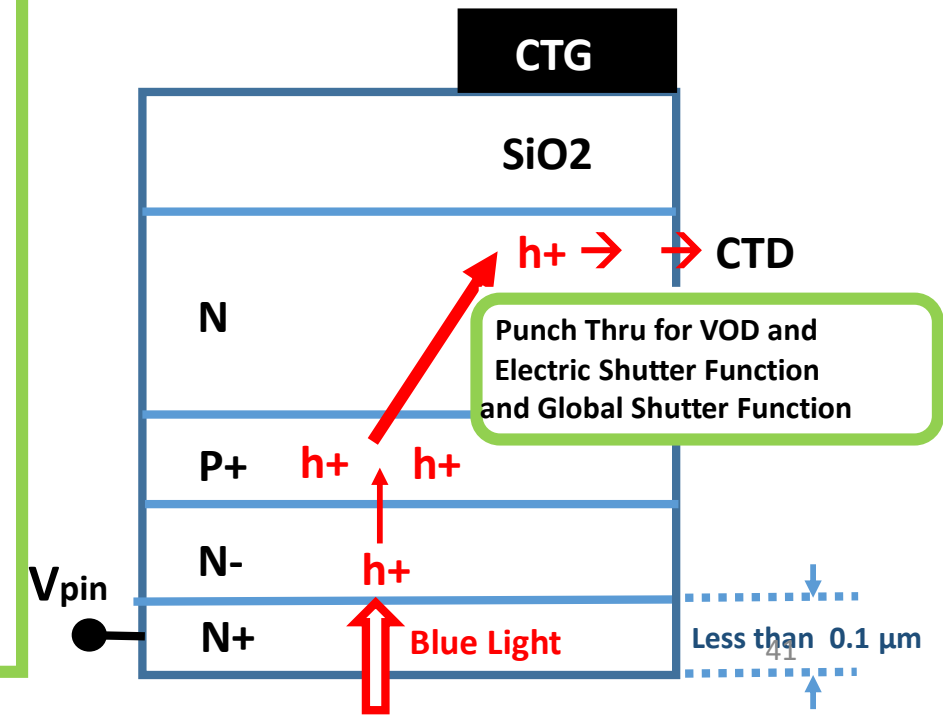

Japanese Patent Application JPA 1975-134985

applied by Yoshiaki Hagiwara at Sony on November 10, 1975

File 1975-134985 Filed 1975/11/10
Public 1977-058414 on 1977/05/13

Buried Pinned Photodiode Patent
the PNP Double Junction type
Dynamic Photo Transistor

with the Vertical Overflow Drain (VOD) Function

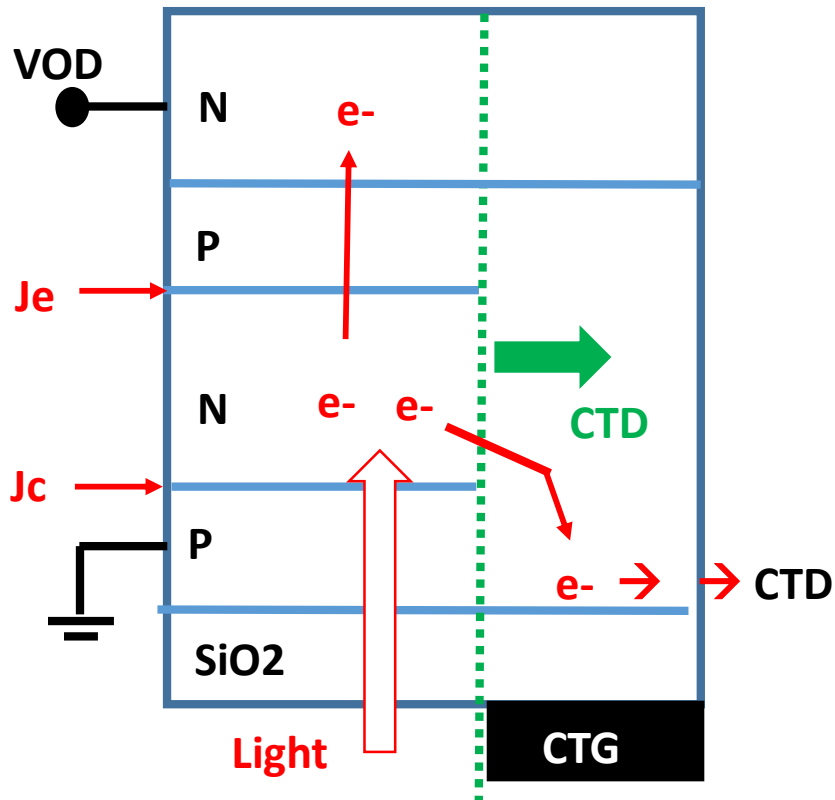

 特許願 (1)
 昭和50年11月10日
 特許庁長官 斎藤英雄殿

1. 発明の名称 コイオンソウソウチ
 固体撮像装置

2. 発明者 ヨコハマ ノド ヤ カリバチヨウ
 住 所 神奈川県横浜市保土ヶ谷区狩場町 303の159
カリバチイ
 狩場台アパート402号室

3. 特許出願人 ハギヘラ ヨシアキ
 氏名 萩原 良昭
ソニー株式会社
 東京都品川区北品川6丁目7番35号
 (218) ソニー株式会社
 代表者 盛田 昭夫

4. 代理人 豊 160
 住 所 東京都新宿区西新宿1丁目8番1号 (新宿ビル)
TEL 東京 (03) 343-5821 (代表)
 氏名 (3388) 弁護士 伊 藤 貞

5. 添付書類の目録
 (1) 明細書 1 通
 (2) 図面 1 通
 (3) 願書原本 1 通
 (4) 委任状 1 通

⑱ 日本国特許庁
公開特許公報
 ①特開昭 52-58414
 ③公開日 昭52.(1977) 5.13
 ②特願昭 50-134985
 ②出願日 昭50.(1975) 11.10
 審査請求 未請求 (全4頁)
 庁内整理番号
 6940 59
 6655 57

| | | |
|---------------------------|--|------|
| ⑤2日本分類 97G01 97G042 | ⑤1 Int.Cl. ² H04N 5/30 H01L 31/00 | 識別記号 |
|---------------------------|--|------|

Title Page of JPA 1975-134985
applied by Yoshiaki Hagiwara at Sony in 1975

Japanese Patent Application JPA 1975-134985

applied by Yoshiaki Hagiwara at Sony on November 10, 1975

File 1975-134985 Filed 1975/11/10
Public 1977-058414 on 1977/05/13

Buried Pinned Photodiode Patent
the PNP Double Junction type
Dynamic Photo Transistor

with the Vertical Overflow Drain (VOD) Function

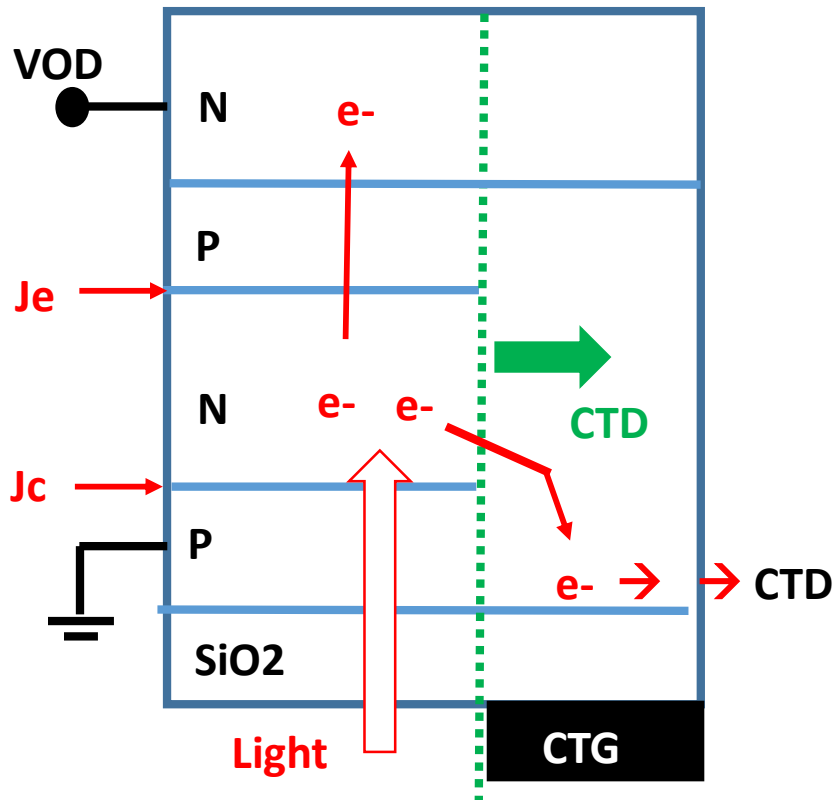

発明の名称 固体撮像装置

特許請求の範囲

半導体基体に、第1導電型の第1半導体領域と、之の上に形成された第2導電型の第2半導体領域とが形成されて光感知部と之よりの電荷を転送する電荷転送部とが上記半導体基体の主面に沿り如く配置されて成る固体撮像装置に於いて、上記光感知部の上記第2半導体領域に整流性接合が形成され、該接合をエミッタ接合とし、上記第1及び第2半導体領域間の接合をコレクタ接合とするトランジスタを形成し、該トランジスタのベースとなる上記第2半導体領域に光学像に応じた電荷を蓄積し、ここに蓄積された電荷を上記転送部に移行させて、その転送を行うようにしたことを特徴とする固体撮像装置。

Patent Claim of JPA 1975-134985

applied by Yoshiaki Hagiwara at Sony in 1975

Japanese Patent Application JPA 1975-134985

applied by Yoshiaki Hagiwara at Sony on November 10, 1975

File 1975-134985 Filed 1975/11/10
Public 1977-058414 on 1977/05/13

Buried Pinned Photodiode Patent
the PNP Double Junction type
Dynamic Photo Transistor

with the Vertical Overflow Drain (VOD) Function

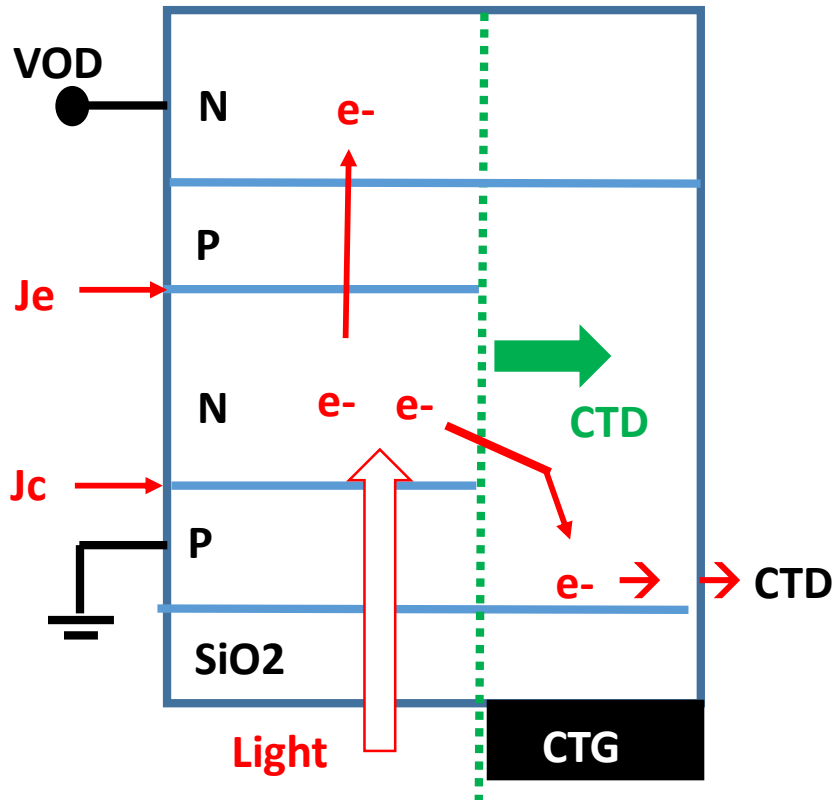

An example of Metal/Semiconductor Junction type
Photon Detector device (PDD)

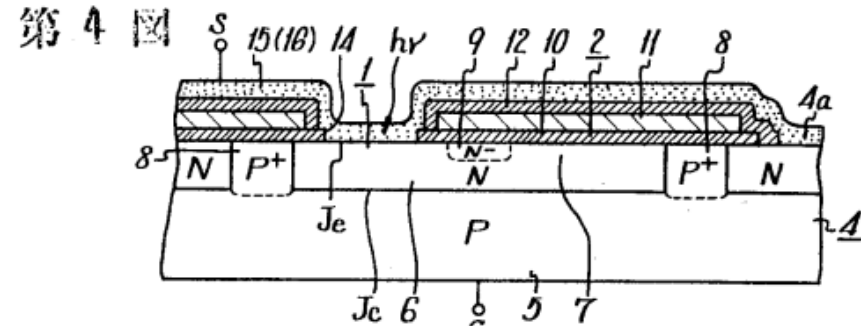

Another Example of PNP Double Junction type
Photon Detector device (PDD)
with the Pinned Surface by Metal Contact with VOD function

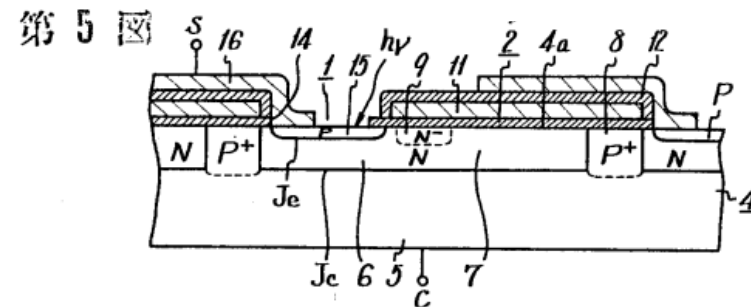

Two Examples of Device Cross Section (Fig. 4 and Fig. 5)
of Photon Detecting Device (PDD)
drawn in JPA 1975-127647 by Yoshiaki Hagiwara

Japanese Patent Application JPA 1975-134985

applied by Yoshiaki Hagiwara at Sony on November 10, 1975

File 1975-134985 Filed 1975/11/10
Public 1977-058414 on 1977/05/13

Buried Pinned Photodiode Patent
the PNP Double Junction type
Dynamic Photo Transistor

with the Vertical Overflow Drain (VOD) Function

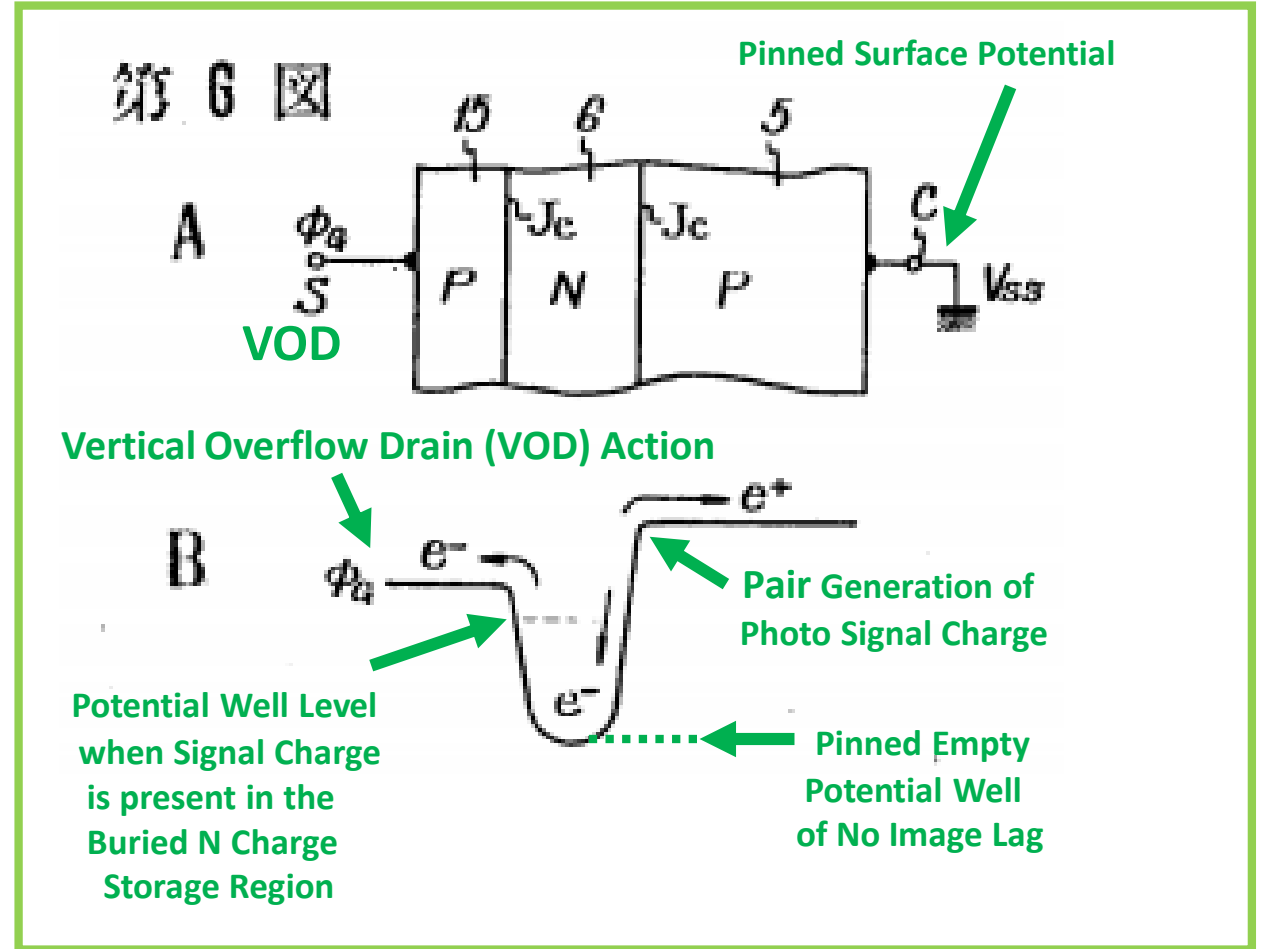
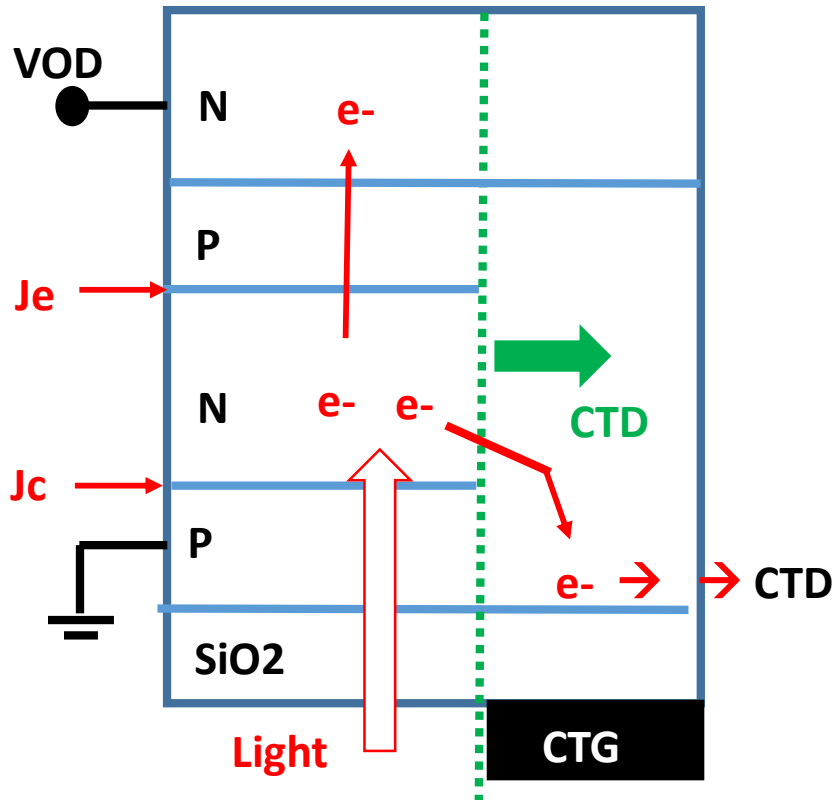

An Example of Device Cross Section (Fig. 6)
of Photon Detecting Device (PDD)
drawn in JPA 1975-134985 by Yoshiaki Hagiwara

Japanese Patent Application JPA 1975-134985

applied by Yoshiaki Hagiwara at Sony on November 10, 1975

File 1975-134985 Filed 1975/11/10
Public 1977-058414 on 1977/05/13

Buried Pinned Photodiode Patent
the PNP Double Junction type
Dynamic Photo Transistor

with the Vertical Overflow Drain (VOD) Function

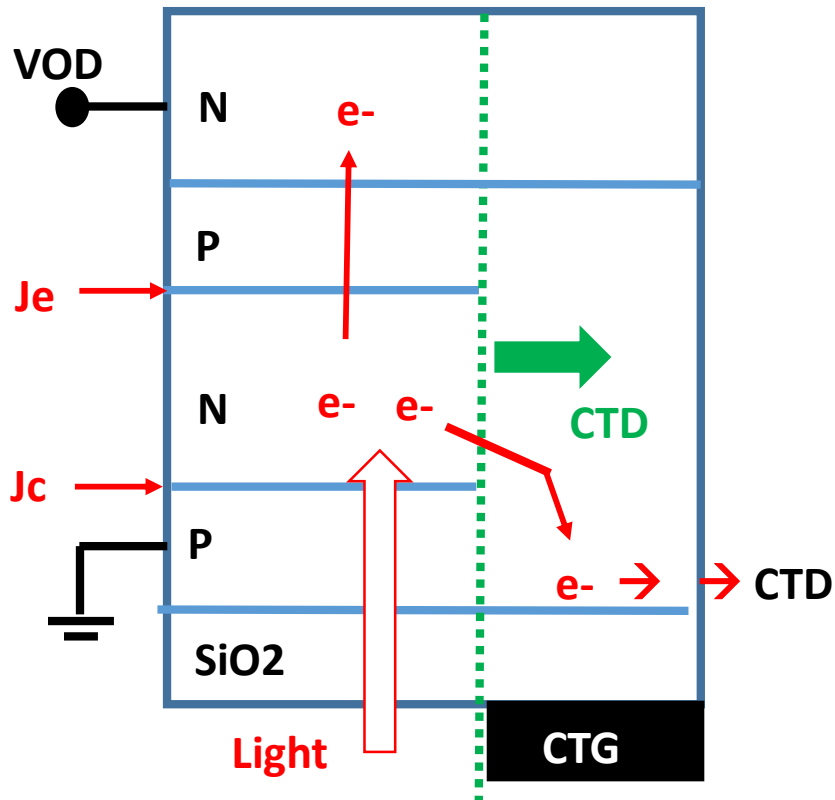

発明の名称 固体撮像装置

特許請求の範囲

半導体基体に、第1導電型の第1半導体領域と、
之の上に形成された第2導電型の第2半導体領域
とが形成されて光感知部と之よりの電荷を転送する
電荷転送部とが上記半導体基体の主面に沿り如く
配置されて成る固体撮像装置に於いて、上記光感
知部の上記第2半導体領域に整流性接合が形成さ
れ、該接合をエミッタ接合とし、上記第1及び第
2半導体領域間の接合をコレクタ接合とするトラ
ンジスタを形成し、該トランジスタのベースとな
る上記第2半導体領域に光学像に応じた電荷を蓄
積し、ここに蓄積された電荷を上記転送部に移行
させて、その転送を行うりようにしたことを特徴と
する固体撮像装置。

Patent Claim of JPA 1975-134985

applied by Yoshiaki Hagiwara at Sony in 1975

Japanese Patent Application JPA 1975-134985

applied by Yoshiaki Hagiwara at Sony on November 10, 1975

Patent Claim in Original Japanese

- 1) 半導体基体(N)に、
- 2) 第1導電型の第1半導体領域(P)と、
之の上に形成された第2導電型の
第2半導体領域(N)とが形成されて
- 3) 光感知部(NP)と之よりの電荷を転送
する電荷転送部(CTD)とが上記半導
体基体の主面に沿う如く配置されて
成る個体撮像装置に於いて
- 4) 上記光感知部(NP)の上記第2半導体領
域(N)に整流性接合が形成され、該接合
をエミッタ接合(Je)とし、
- 5) 上記第1及び第2半導体領域間の接合
をコレクタ接合(Jc)とするトランジ
スタ(PNP)を形成し、
- 6) 該トランジスタ(PNP)のベースとなる上記
第2半導体領域(N)に光学像に応じた電
荷を蓄積し
- 7) ここ(N)に蓄積された電荷を上記転送
部に移行させて、その転送を行うよう
にしたことを特徴とする個体撮像装置

発明の名称 固体撮像装置

特許請求の範囲

半導体基体に、第1導電型の第1半導体領域と、
之の上に形成された第2導電型の第2半導体領域
とが形成されて光感知部と之よりの電荷を転送する
電荷転送部とが上記半導体基体の主面に沿う如く
配置されて成る固体撮像装置に於いて、上記光感
知部の上記第2半導体領域に整流性接合が形成さ
れ、該接合をエミッタ接合とし、上記第1及び第
2半導体領域間の接合をコレクタ接合とするトラ
ンジスタを形成し、該トランジスタのベースとな
る上記第2半導体領域に光学像に応じた電荷を蓄
積し、ここに蓄積された電荷を上記転送部に移行
させて、その転送を行うようにしたことを特徴と
する固体撮像装置。

Patent Claim of JPA 1975-134985

applied by Yoshiaki Hagiwara at Sony in 1975

Japanese Patent Application JPA 1975-134985

applied by Yoshiaki Hagiwara at Sony on November 10, 1975

Patent Claim in Original Japanese

- 1) 半導体基体(N)に、
- 2) 第1導電型の第1半導体領域(P)と、
之の上に形成された第2導電型の
第2半導体領域(N)とが形成されて
- 3) 光感知部(NP)と之よりの電荷を転送
する電荷転送部(CTD)とが上記半導
体基体の主面に沿う如く配置されて
成る個体撮像装置に於いて
- 4) 上記光感知部(NP)の上記第2半導体領
域(N)に整流性接合が形成され、該接合
をエミッタ接合(Je)とし、
- 5) 上記第1及び第2半導体領域間の接合
をコレクタ接合(Jc)とするトランジ
スタ(PNP)を形成し、
- 6) 該トランジスタ(PNP)のベースとなる上記
第2半導体領域(N)に光学像に応じた電
荷を蓄積し
- 7) ここ(N)に蓄積された電荷を上記転送
部に移行させて、その転送を行うよう
にしたことを特徴とする個体撮像装置

File 1975-134985 Filed 1975/11/10
Public 1977-058414 on 1977/05/13

Buried Pinned Photodiode Patent
the PNP Double Junction type
Dynamic Photo Transistor
with the Vertical Overflow Drain (VOD) Function

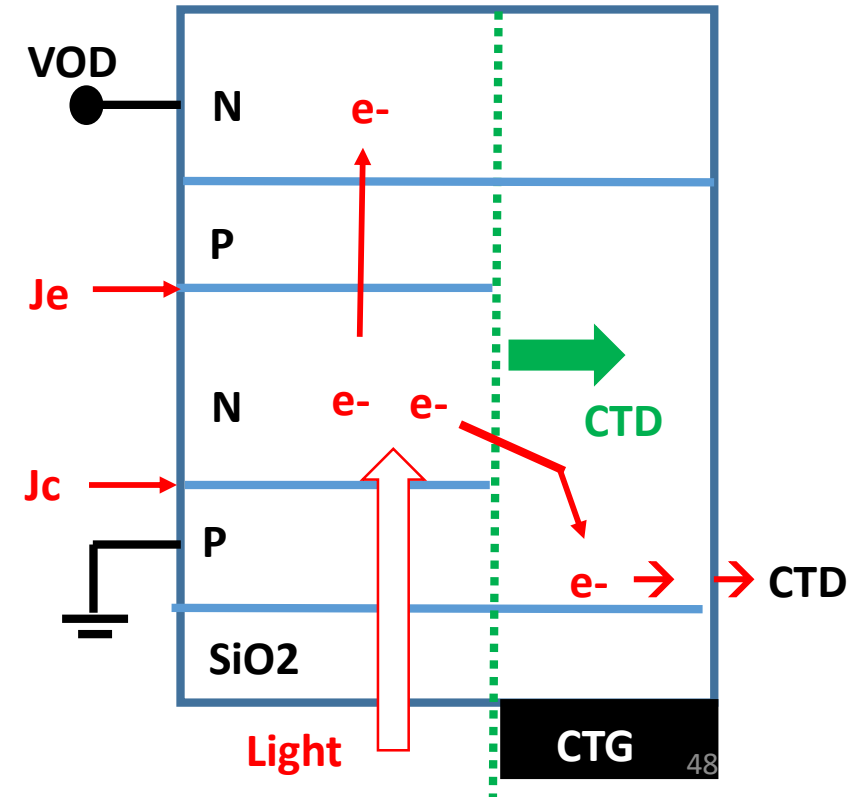

Japanese Patent Application JPA 1975-134985

applied by Yoshiaki Hagiwara at Sony on November 10, 1975

Patent Claim in Original Japanese

- 1) 半導体基体(N)に、
- 2) 第1導電型の第1半導体領域(P)と、
之の上に形成された第2導電型の
第2半導体領域(N)とが形成されて
- 3) 光感知部(NP)と之よりの電荷を転送
する電荷転送部(CTD)とが上記半導
体基体の主面に沿う如く配置されて
成る個体撮像装置に於いて
- 4) 上記光感知部(NP)の上記第2半導体領
域(N)に整流性接合が形成され、該接合
をエミッタ接合(Je)とし、
- 5) 上記第1及び第2半導体領域間の接合
をコレクタ接合(Jc)とするトランジ
スタ(PNP)を形成し、
- 6) 該トランジスタ(PNP)のベースとなる上記
第2半導体領域(N)に光学像に応じた電
荷を蓄積し
- 7) ここ(N)に蓄積された電荷を上記転送
部に移行させて、その転送を行うよう
にしたことを特徴とする個体撮像装置

Patent Claim in English Translation

- 1) In the semiconductor basic body (N),
- 2) the first region (P) of the first impurity is formed,
and on which the second region
(N) of the second impurity type is formed.
- 3) The photo sensor (NP) so defined forms
a solid state image sensor with Charge
Transfer Device (CTD) placed along the surface of
the semiconductor basic body.
- 4) A rectifying emitter junction (Je) is
formed on the second region (N) of
the photo sensor (NP).
- 5) The junction between the first region
(P) and the second region (N).being
as the collector junction (Jc) of the
transistor (PNP),
- 6) the second region (N)becomes the base region of
the transistor (PNP) which
stores the photo charge according to
the photo image.
- 7) And the charge stored in this region (N)
is transferred to the Charge Transfer Device
(CTD).

File 1975-134985 Filed 1975/11/10
Public 1977-058414 on 1977/05/13

Buried Pinned Photodiode Patent
the PNP Double Junction type
Dynamic Photo Transistor
with the Vertical Overflow Drain (VOD) Function

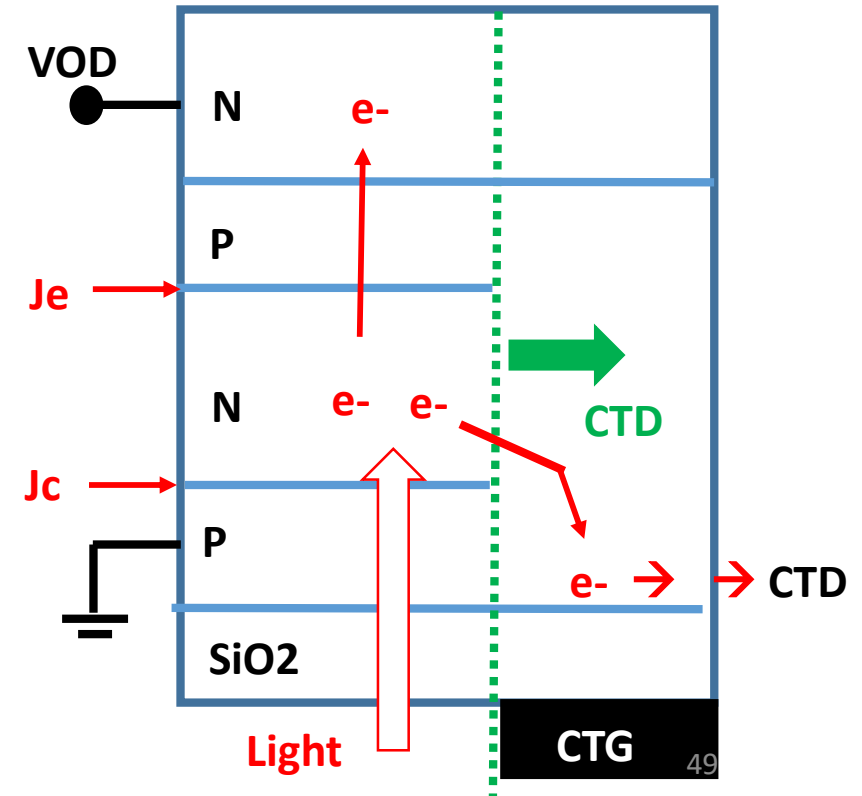

Japanese Patent Application JPA 1975-134985

applied by Yoshiaki Hagiwara at Sony on November 10, 1975

Patent Claim in Original Japanese

1) 半導体基体(N)に、

Patent Claim in English Translation

1) In the semiconductor basic body (N),

File 1975-134985 Filed 1975/11/10
Public 1977-058414 on 1977/05/13

Buried Pinned Photodiode Patent
the PNP Double Junction type
Dynamic Photo Transistor
with the Vertical Overflow Drain (VOD) Function

N

Japanese Patent Application JPA 1975-134985

applied by Yoshiaki Hagiwara at Sony on November 10, 1975

Patent Claim in Original Japanese

- 1) 半導体基体(N)に、
- 2) 第1導電型の第1半導体領域(P)と、
之の上に形成された第2導電型の
第2半導体領域(N)とが形成されて

Patent Claim in English Translation

- 1) In the semiconductor basic body (N),
- 2) the first region (P) of the first impurity is formed,
and on which the second region
(N) of the second impurity type is formed.

File 1975-134985 Filed 1975/11/10
Public 1977-058414 on 1977/05/13

Buried Pinned Photodiode Patent
the PNP Double Junction type
Dynamic Photo Transistor
with the Vertical Overflow Drain (VOD) Function

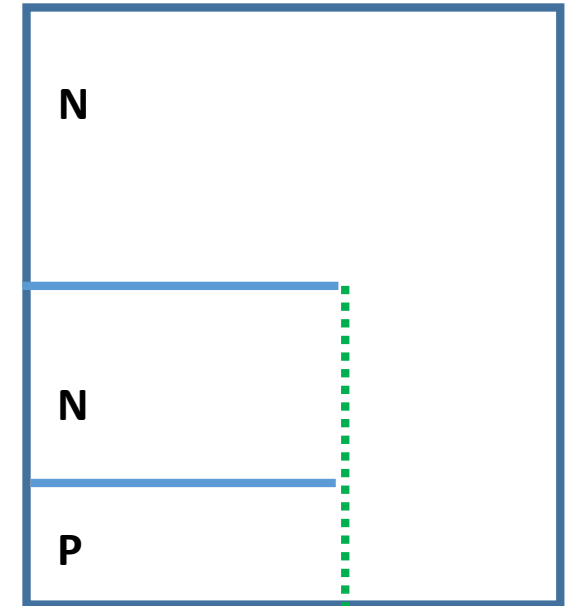

Japanese Patent Application JPA 1975-134985

applied by Yoshiaki Hagiwara at Sony on November 10, 1975

Patent Claim in Original Japanese

- 1) 半導体基体(N)に、
- 2) 第1導電型の第1半導体領域(P)と、
之の上に形成された第2導電型の
第2半導体領域(N)とが形成されて
- 3) 光感知部(NP)と之よりの電荷を転送
する電荷転送部(CTD)とが上記半導
体基体の主面に沿う如く配置されて
成る個体撮像装置に於いて

Patent Claim in English Translation

- 1) In the semiconductor basic body (N),
- 2) the first region (P) of the first impurity is formed,
and on which the second region
(N) of the second impurity type is formed.
- 3) The photo sensor (NP) so defined forms
a solid state image sensor with Charge
Transfer Device (CTD) placed along the surface of
the semiconductor basic body.

File 1975-134985 Filed 1975/11/10
Public 1977-058414 on 1977/05/13

Buried Pinned Photodiode Patent
the PNP Double Junction type
Dynamic Photo Transistor
with the Vertical Overflow Drain (VOD) Function

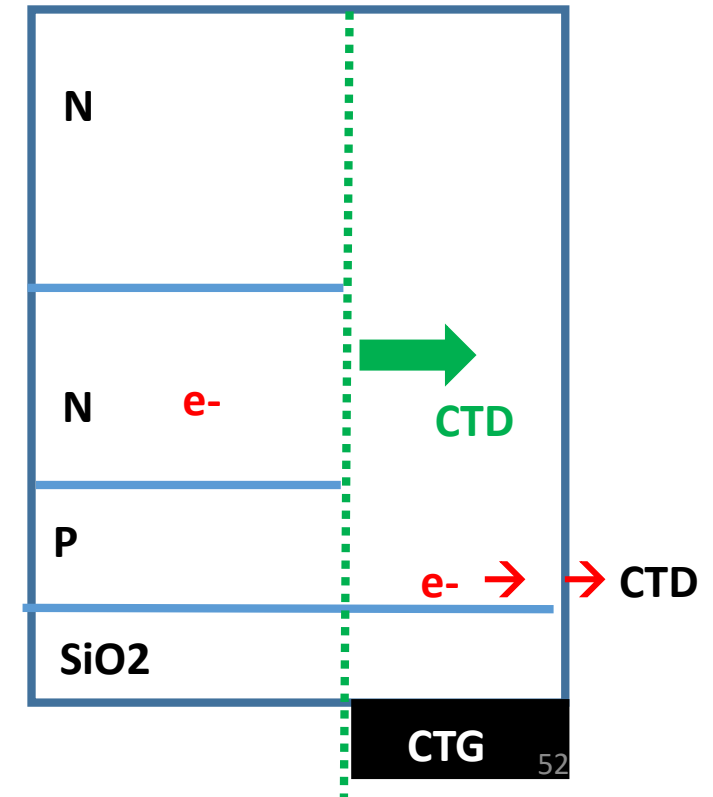

Japanese Patent Application JPA 1975-134985

applied by Yoshiaki Hagiwara at Sony on November 10, 1975

Patent Claim in Original Japanese

- 1) 半導体基体(N)に、
- 2) 第1導電型の第1半導体領域(P)と、
之の上に形成された第2導電型の
第2半導体領域(N)とが形成されて
- 3) 光感知部(NP)と之よりの電荷を転送
する電荷転送部(CTD)とが上記半導
体基体の主面に沿う如く配置されて
成る個体撮像装置に於いて
- 4) 上記光感知部(NP)の上記第2半導体領
域(N)に整流性接合が形成され、該接合
をエミッタ接合(Je)とし、

Patent Claim in English Translation

- 1) In the semiconductor basic body (N),
- 2) the first region (P) of the first impurity is formed,
and on which the second region
(N) of the second impurity type is formed.
- 3) The photo sensor (NP) so defined forms
a solid state image sensor with Charge
Transfer Device (CTD) placed along the surface of
the semiconductor basic body.
- 4) A rectifying emitter junction (Je) is
formed on the second region (N) of
the photo sensor (NP).

File 1975-134985 Filed 1975/11/10
Public 1977-058414 on 1977/05/13

Buried Pinned Photodiode Patent
the PNP Double Junction type
Dynamic Photo Transistor
with the Vertical Overflow Drain (VOD) Function

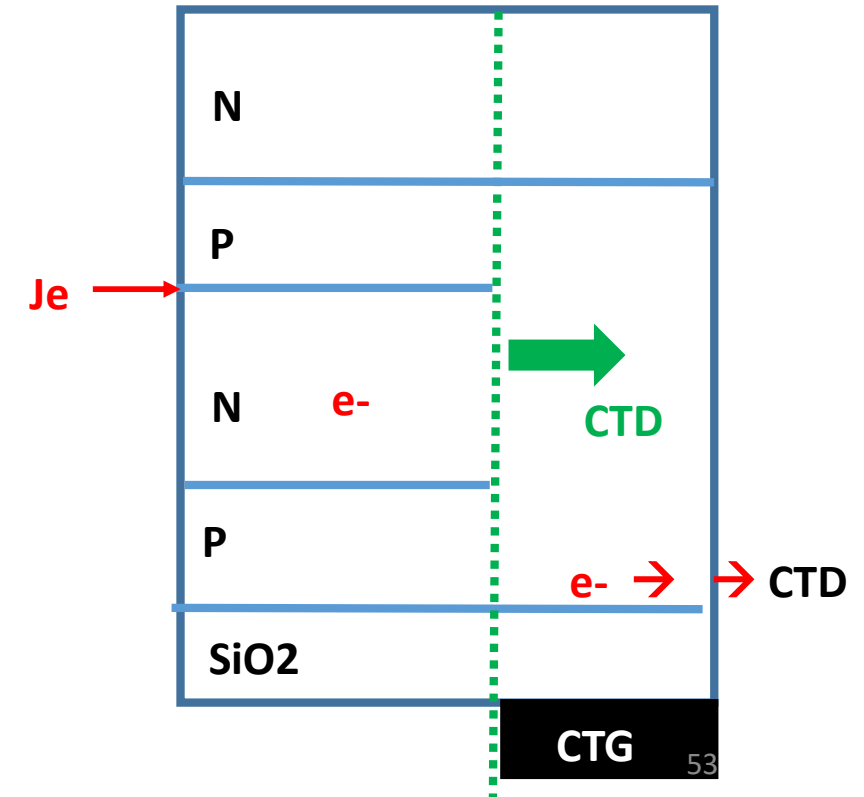

Japanese Patent Application JPA 1975-134985

applied by Yoshiaki Hagiwara at Sony on November 10, 1975

Patent Claim in Original Japanese

- 1) 半導体基体(N)に、
- 2) 第1導電型の第1半導体領域(P)と、
之の上に形成された第2導電型の
第2半導体領域(N)とが形成されて
- 3) 光感知部(NP)と之よりの電荷を転送
する電荷転送部(CTD)とが上記半導
体基体の主面に沿う如く配置されて
成る個体撮像装置に於いて
- 4) 上記光感知部(NP)の上記第2半導体領
域(N)に整流性接合が形成され、該接合
をエミッタ接合(Je)とし、
- 5) 上記第1及び第2半導体領域間の接合
をコレクタ接合(Jc)とするトランジ
スタ(PNP)を形成し、

Patent Claim in English Translation

- 1) In the semiconductor basic body (N),
- 2) the first region (P) of the first impurity is formed,
and on which the second region
(N) of the second impurity type is formed.
- 3) The photo sensor (NP) so defined forms
a solid state image sensor with Charge
Transfer Device (CTD) placed along the surface of
the semiconductor basic body.
- 4) A rectifying emitter junction (Je) is
formed on the second region (N) of
the photo sensor (NP).
- 5) The junction between the first region
(P) and the second region (N).being
as the collector junction (Jc) of the
transistor (PNP),

File 1975-134985 Filed 1975/11/10
Public 1977-058414 on 1977/05/13

Buried Pinned Photodiode Patent
the PNP Double Junction type
Dynamic Photo Transistor
with the Vertical Overflow Drain (VOD) Function

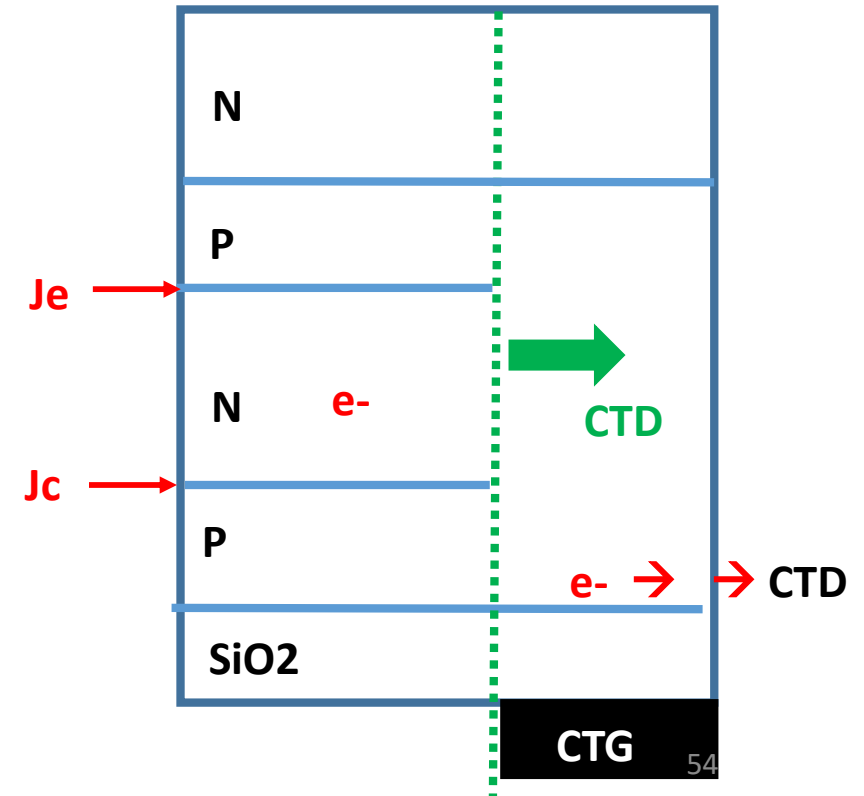

Japanese Patent Application JPA 1975-134985

applied by Yoshiaki Hagiwara at Sony on November 10, 1975

Patent Claim in Original Japanese

- 1) 半導体基体(N)に、
- 2) 第1導電型の第1半導体領域(P)と、
之の上に形成された第2導電型の
第2半導体領域(N)とが形成されて
- 3) 光感知部(NP)と之よりの電荷を転送
する電荷転送部(CTD)とが上記半導
体基体の主面に沿う如く配置されて
成る個体撮像装置に於いて
- 4) 上記光感知部(NP)の上記第2半導体領
域(N)に整流性接合が形成され、該接合
をエミッタ接合(Je)とし、
- 5) 上記第1及び第2半導体領域間の接合
をコレクタ接合(Jc)とするトランジ
スタ(PNP)を形成し、
- 6) 該トランジスタ(PNP)のベースとなる上記
第2半導体領域(N)に光学像に応じた電
荷を蓄積し

Patent Claim in English Translation

- 1) In the semiconductor basic body (N),
- 2) the first region (P) of the first impurity is formed,
and on which the second region
(N) of the second impurity type is formed.
- 3) The photo sensor (NP) so defined forms
a solid state image sensor with Charge
Transfer Device (CTD) placed along the surface of
the semiconductor basic body.
- 4) A rectifying emitter junction (Je) is
formed on the second region (N) of
the photo sensor (NP).
- 5) The junction between the first region
(P) and the second region (N).being
as the collector junction (Jc) of the
transistor (PNP),
- 6) the second region (N) becomes the base region of
the transistor (PNP) which
stores the photo charge according to
the photo image.

File 1975-134985 Filed 1975/11/10
Public 1977-058414 on 1977/05/13

Buried Pinned Photodiode Patent
the PNP Double Junction type
Dynamic Photo Transistor
with the Vertical Overflow Drain (VOD) Function

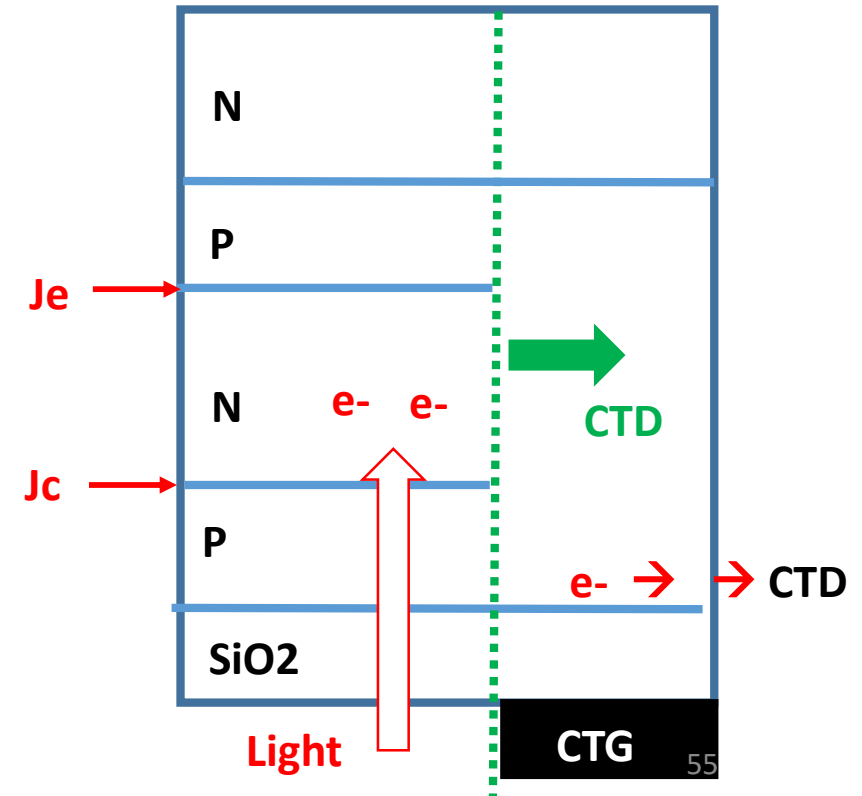

Japanese Patent Application JPA 1975-134985

applied by Yoshiaki Hagiwara at Sony on November 10, 1975

Patent Claim in Original Japanese

- 1) 半導体基体(N)に、
- 2) 第1導電型の第1半導体領域(P)と、
之の上に形成された第2導電型の
第2半導体領域(N)とが形成されて
- 3) 光感知部(NP)と之よりの電荷を転送
する電荷転送部(CTD)とが上記半導
体基体の主面に沿う如く配置されて
成る個体撮像装置に於いて
- 4) 上記光感知部(NP)の上記第2半導体領
域(N)に整流性接合が形成され、該接合
をエミッタ接合(Je)とし、
- 5) 上記第1及び第2半導体領域間の接合
をコレクタ接合(Jc)とするトランジ
スタ(PNP)を形成し、
- 6) 該トランジスタ(PNP)のベースとなる上記
第2半導体領域(N)に光学像に応じた電
荷を蓄積し
- 7) ここ(N)に蓄積された電荷を上記転送
部に移行させて、その転送を行うよう
にしたことを特徴とする個体撮像装置

Patent Claim in English Translation

- 1) In the semiconductor basic body (N),
- 2) the first region (P) of the first impurity is formed,
and on which the second region
(N) of the second impurity type is formed.
- 3) The photo sensor (NP) so defined forms
a solid state image sensor with Charge
Transfer Device (CTD) placed along the surface of
the semiconductor basic body.
- 4) A rectifying emitter junction (Je) is
formed on the second region (N) of
the photo sensor (NP).
- 5) The junction between the first region
(P) and the second region (N).being
as the collector junction (Jc) of the
transistor (PNP),
- 6) the second region (N) becomes the base region of
the transistor (PNP) which
stores the photo charge according to
the photo image.
- 7) And the charge stored in this region (N)
is transferred to the Charge Transfer Device
(CTD).

File 1975-134985 Filed 1975/11/10
Public 1977-058414 on 1977/05/13

Buried Pinned Photodiode Patent
the PNP Double Junction type
Dynamic Photo Transistor
with the Vertical Overflow Drain (VOD) Function

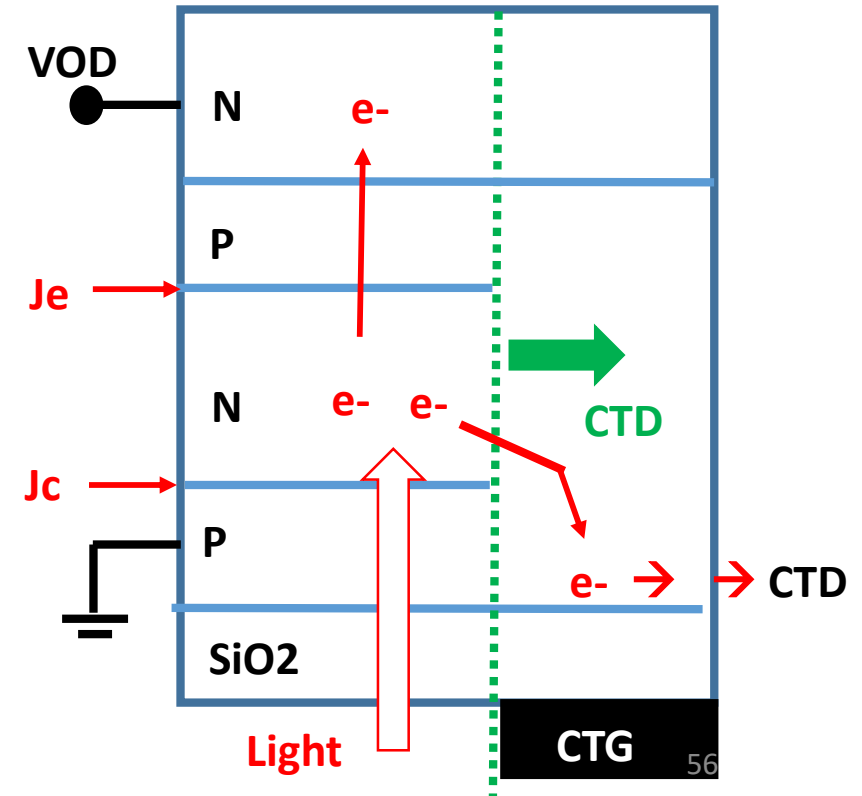

SONY HAD (Pinned Photodiode) Publications at the International Solid State Device Conference in 1978 and the Tokyo & New York SONY Press Conference in 1980

The original Pinned Photodiode (PPD) structure was invented by Hagiwara at Sony in 1975. The first one-chip color video camera with a FT CCD image sensor with P+NP junction type Pinned Photodiode (PPD) was reported by Sony in 1980 at Tokyo Press Conference by Iwama Kazuo of Sony president, and at New York Press conference by Morita Akio of Sony chairman.

Sony original 570H x 498 V one-chip FT CCD Image Sensor with Pinned Photodiode, July 1980



On July 1980, Iwama Kazuo at Sony Tokyo Press Conference and Morita Akio at New York Press Conference announced the one chip CCD video camera with the 8 mm VTR in one box.

See the Original 1978 Publication of the Pinned Photodiode Sensor

Y. Daimon-Hagiwara, M. Abe, and C. Okada, "A 380Hx488V CCD imager with narrow channel transfer gates," Proceedings of the 10th Conference on Solid State Devices, Tokyo, 1978; Japanese Journal of Applied Physics, vol. 18, supplement 18-1, pp. 335-340, 1979

High quality picture of SONY CMOS Imager is also based on SONY HAD (Pinned Photodiode).

Hagiwara invented Pinned Photodiode (PPD).

Japanese Patent Applications, JPA1975-127646, JPA1975-127647 and JPA 1975-134985, filed by Yoshiaki Hagiwara at Sony in 1975, show that Hagiwara invented Buried Photodiode (BPD) with the Pinned Surface Hole Accumulation, Pinned Photodiode (PPD) and Hole Accumulation Diode (HAD). It is also evident that Hagiwara invented Global Shutter Scheme of the three level clocking with MOS Capacitor Buffer Memory, clearly shown in JPA 1975-127646 and JPA 1975-127647. It is also evident that Hagiwara et al invented the Electrical Shutter Clocking Scheme by controlling punch-thru action of the in-pixel overflow drain (OFD) voltage as evidenced in JPA 1977-136885.

The most important idea of the P+NP Double Junction Buried Pinned Photodiode proposed by Hagiwara in the 1975-134985 Japanese Patent Application is the virtual complete charge transfer operation with no image lag which does not need the conventional double polysilicon overlapping CCD process with very poor productivity.

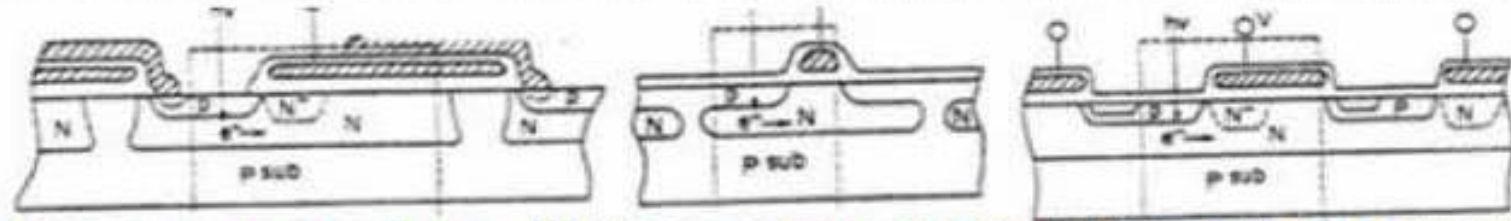

(1) Hagiwara 1975 P+NP PPD JPA 1975-134985 (2) Hagiwara 1978 P+NP PPD SSDM1978 paper (3) Henecek 1979 P+NP PPD

This may have a problem ??
The reason is explained below.

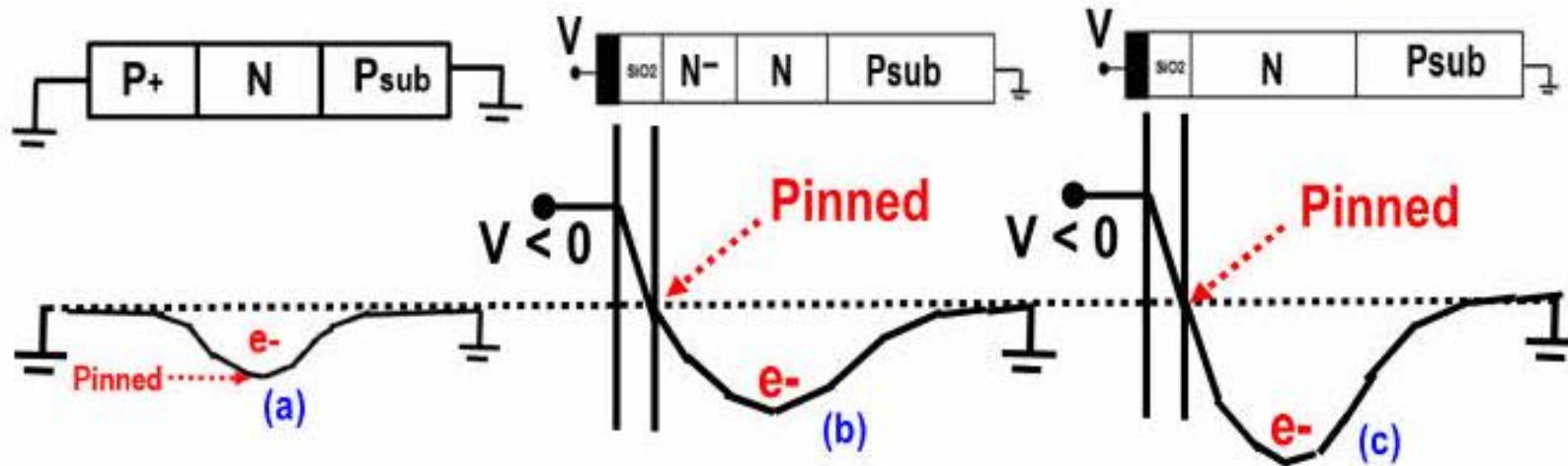

Even though the gate voltage $V < 0$ is set at a strong negative value, the silicon surface potential will be in the hole accumulation condition with the Pinned grounded voltage level. The buried channel CCD potentials (b) and (c) are always deeper than the Pinned Empty Potential (a) of the Pinned Photodiode.

Hagiwara invented Pinned Photodiode (PPD).

Japanese Patent Applications, JPA1975-127646, JPA1975-127647 and JPA 1975-134985, filed by Yoshiaki Hagiwara at Sony in 1975, show that Hagiwara invented Buried Photodiode (BPD) with the Pinned Surface Hole Accumulation, Pinned Photodiode (PPD) and Hole Accumulation Diode (HAD). It is also evident that Hagiwara invented Global Shutter Scheme of the three level clocking with MOS Capacitor Buffer Memory, clearly shown in JPA 1975-127646 and JPA 1975-127647. It is also evident that Hagiwara et al invented the Electrical Shutter Clocking Scheme by controlling punch-thru action of the in-pixel overflow drain (OFD) voltage as evidenced in JPA 1977-136885.

Fig. 5 of the Japanese Patent Application JPA 1975-134985 shows the P+NP double junction type Pinned Photodiode with the VOD function

PPD needs P+ Channel Stops.

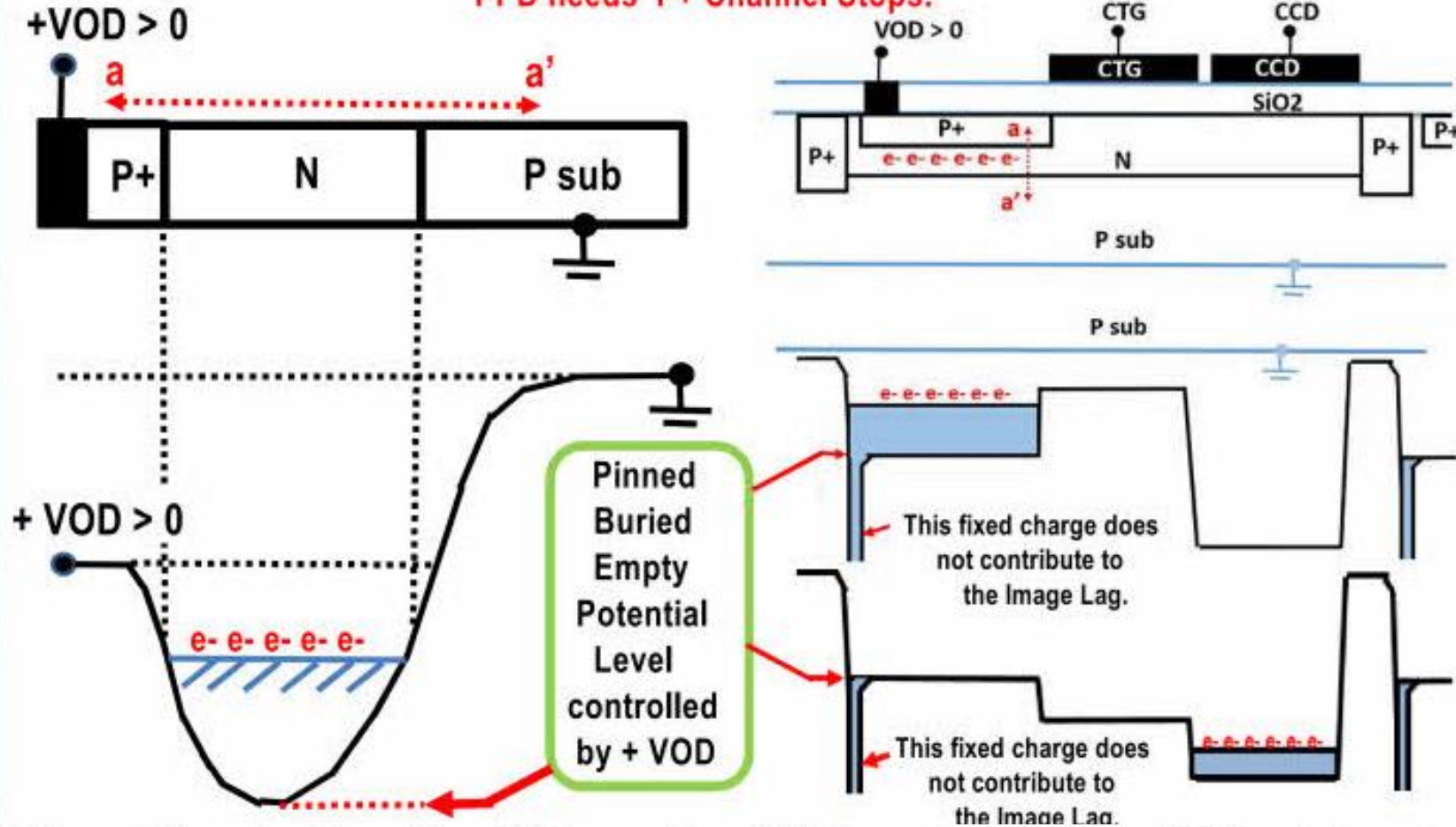

VOD metal contact is optional. If the surface VOD is not needed, the VOD metal contact can be deleted and the surface P+ can be connected to the adjacent P+ channel stops.

Hagiwara invented Pinned Photodiode (PPD).

Japanese Patent Applications, JPA1975-127646, JPA1975-127647 and JPA 1975-134985, filed by Yoshiaki Hagiwara at Sony in 1975, show that Hagiwara invented Buried Photodiode (BPD) with the Pinned Surface Hole Accumulation, Pinned Photodiode (PPD) and Hole Accumulation Diode (HAD). It is also evident that Hagiwara invented Global Shutter Scheme of the three level clocking with MOS Capacitor Buffer Memory, clearly shown in JPA 1975-127646 and JPA 1975-127647. It is also evident that Hagiwara et al invented the Electrical Shutter Clocking Scheme by controlling punch-thru action of the in-pixel overflow drain (OFD) voltage as evidenced in JPA 1977-136885.

Hagiwara invented Pinned Photodiode (PPD).

Japanese Patent Applications, JPA1975-127646, JPA1975-127647 and JPA 1975-134985, filed by Yoshiaki Hagiwara at Sony in 1975, show that Hagiwara invented Buried Photodiode (BPD) with the Pinned Surface Hole Accumulation, Pinned Photodiode (PPD) and Hole Accumulation Diode (HAD). It is also evident that Hagiwara invented Global Shutter Scheme of the three level clocking with MOS Capacitor Buffer Memory, clearly shown in JPA 1975-127646 and JPA 1975-127647. It is also evident that Hagiwara et al invented the Electrical Shutter Clocking Scheme by controlling punch-thru action of the in-pixel overflow drain (OFD) voltage as evidenced in JPA 1977-136885.

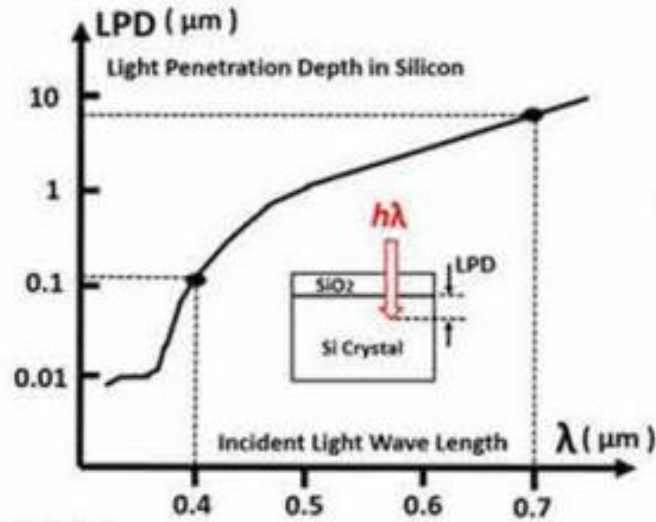

Drift Field Transistor

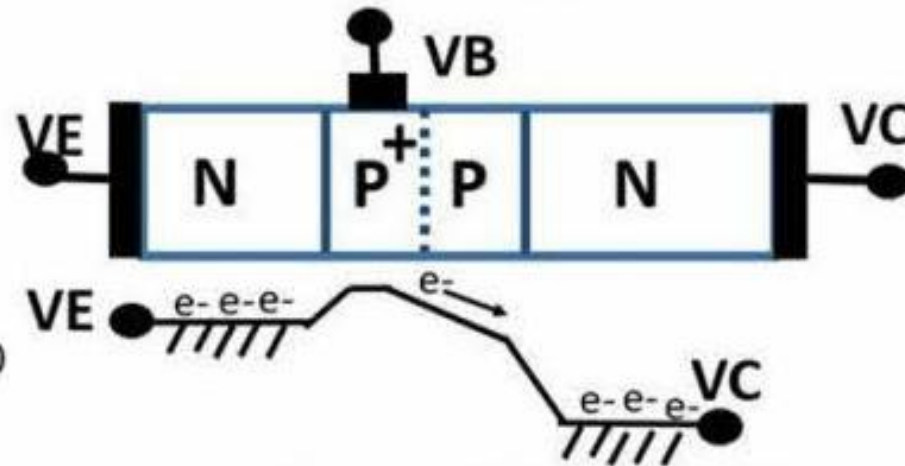
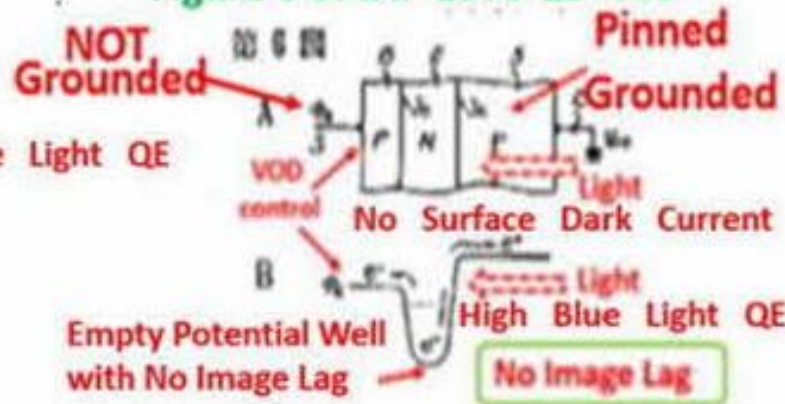

Figure 7 of JAP 1975-127647

Figure 6 of JAP 1975-134985



Hagiwara invented PNP junction type PPD in 1975 with (1) blue light 100% QE, (2) No Surface Dark Current and (3) No Image Lag, Complete Charge Transfer features.

Back Light Illumination
Sony CMOS Image Sensor (2020)

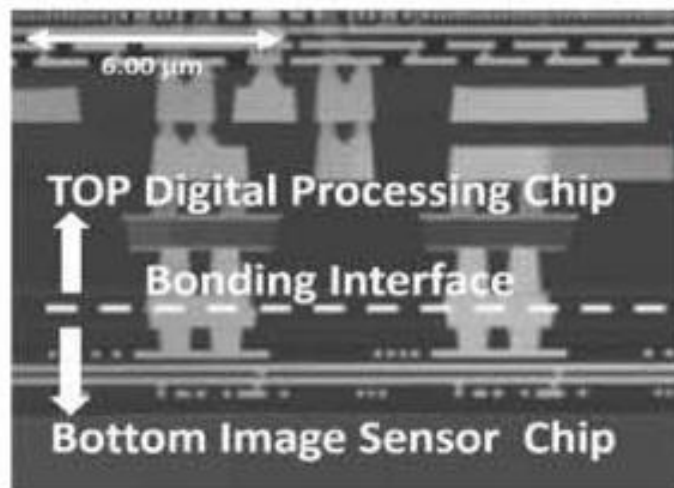

Multi-chips three dimensional LSI chip

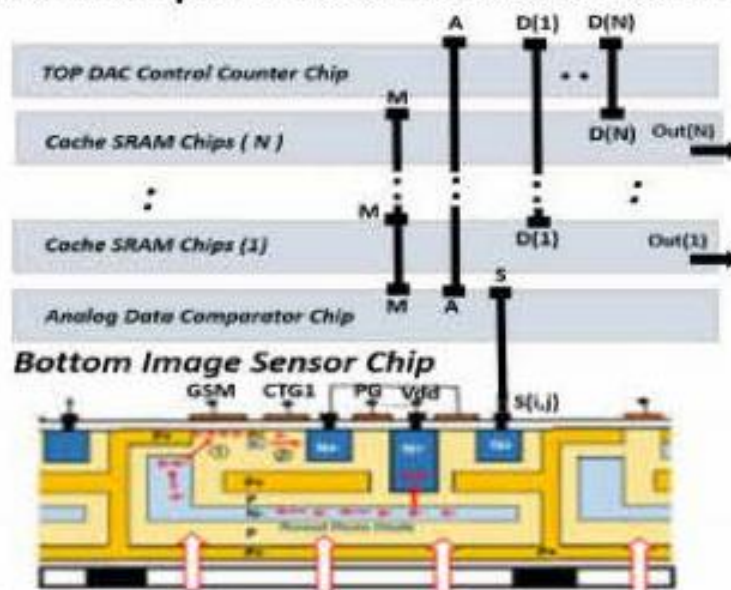
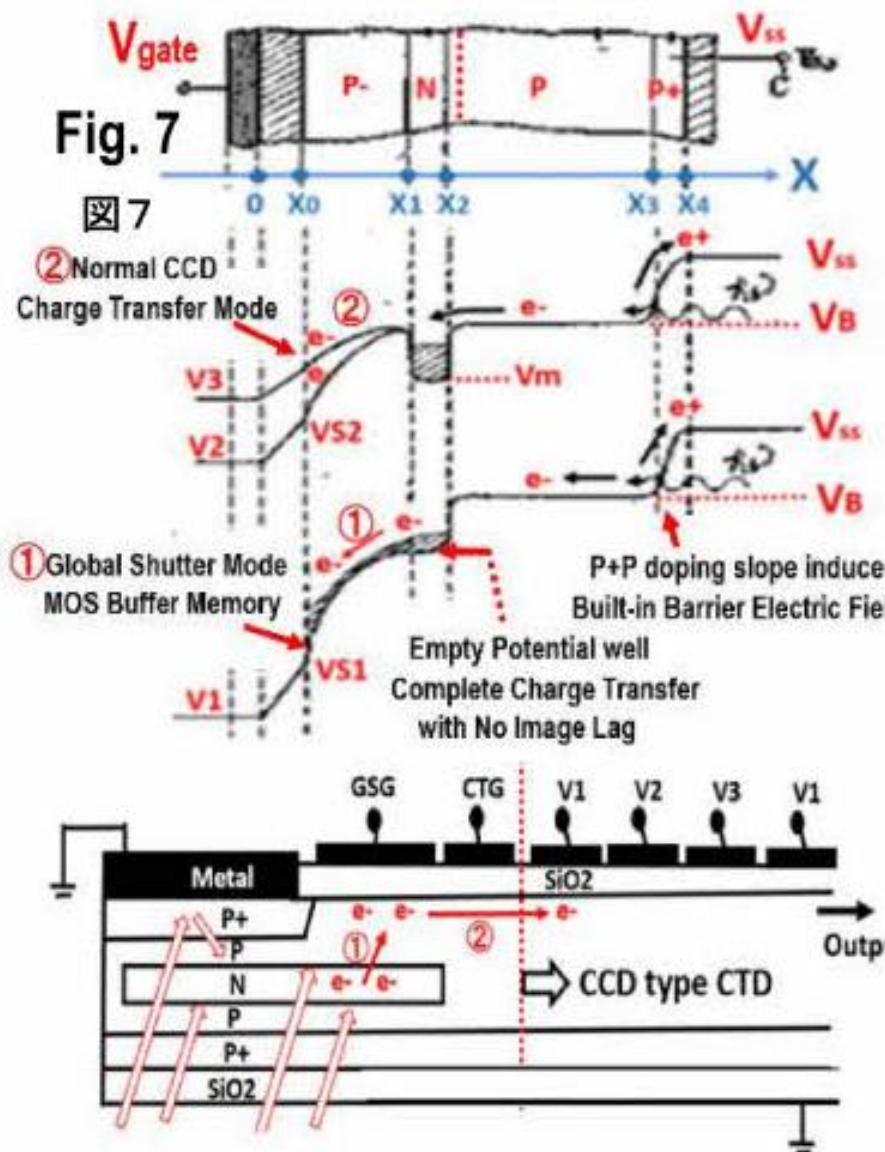

Image Sensor Story

P+PNPP+ Junction Buried Pinned Photodiode
for Back Light (JAP 1975-127647)



Hagiwara invented Pinned Photodiode (PPD).

Japanese Patent Applications, JPA1975-127646, JPA1975-127647 and JPA 1975-134985, filed by Yoshiaki Hagiwara at Sony in 1975, show that Hagiwara invented Buried Photodiode (BPD) with the Pinned Surface Hole Accumulation, Pinned Photodiode (PPD) and Hole Accumulation Diode (HAD). It is also evident that Hagiwara invented Global Shutter Scheme of the three level clocking with MOS Capacitor Buffer Memory, clearly shown in JPA 1975-127646 and JPA 1975-127647. It is also evident that Hagiwara et al invented the Electrical Shutter Clocking Scheme by controlling punch-thru action of the in-pixel overflow drain (OFD) voltage as evidenced in JPA 1977-136885.

Fossum insulted in his 2014 paper Sony and Hagiwara 1975 PPD invention.

Indeed, Hagiwara invented PPD with VOD and the virtual charge transfer in 1975 !!

IEEE JOURNAL OF THE ELECTRON DEVICES SOCIETY, VOL. 2, NO. 3, MAY 2014

23

Sony HAD (PPD+VOD) does not use LOCOS !!!

A Review of the Pinned Photodiode for CCD and CMOS Image Sensors

Eric R. Fossum, *Fellow, IEEE*, and Donald B. Hondongwa, *Student Member, IEEE*

Many people now said this is a fake paper !

False

C. Other Contributions to the PPD Invention

The PPD structure, while invented for low lag ILT CCD application, shares a strong resemblance to the Hynecck virtual-phase CCD structure, with the exception of the VOD. The two inventions were solving different problems with essentially the same device structure and operating principles.

In 1975, Hagiwara at Sony filed a patent application on bipolar structures for CCDs in which a *ppp* vertical structure was disclosed, among several structures [24]. The top *p* layer was connected by metal to a bias used to control full-well capacity and the *n*-type base layer was proposed for carrier storage. In an unusual paper, Hagiwara, in 1996, revisited the 1975 invention and claimed it was essentially the invention of both the virtual phase CCD and the NEC low-lag structures, as well as the basis of the Sony so-called "Hole Accumulation Diode," or HAD structure [25]. However, the 1975 application

False

did not address complete charge transfer, lag or anti-blooming properties found in the NEC low-lag device, and does not seem to contain the built-in potential step and charge transfer device aspects of the virtual-phase CCD. Hagiwara repeats these claims in a 2001 paper [26] and shows a VOD structure that is not found in the 1975 patent application. Sony did not seem to pursue the HAD structure until well after the NEC paper was published. However, the "narrow-gate" CCD with an open *p*-type surface region for improved QE also disclosed in the 1975 application was reported in more detail by Hagiwara et al. at Sony in 1978 [27]. A similar structure was used extensively by Philips [28].

The PPD, as it is most commonly used today, bears the strongest resemblance to the Teranishi et al. ILT CCD device. Thus, these days Teranishi is considered as the primary inventor of the modern PPD [29].

The surface P+ layer is NOT connected to the LOCOS P+ layer. The surface P+ layer may be floating and this photodiode may have serious image lag.

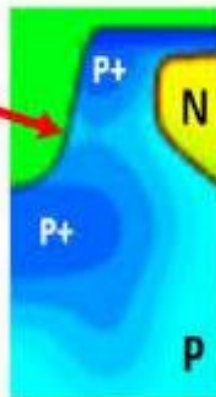

Serious Image Lag ?

NOT connected

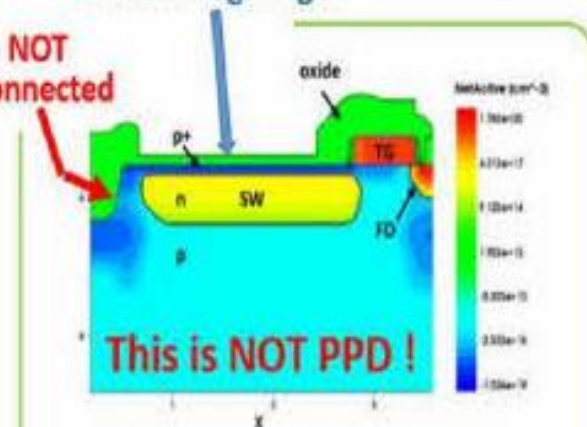

Fig. 4. Example of a pinned photodiode implemented in a CMOS image sensor showing doping concentrations. (Dimensional units are microns).

This is NOT PPD !

Hagiwara invented Pinned Photodiode (PPD).

Japanese Patent Applications, JPA1975-127646, JPA1975-127647 and JPA 1975-134985, filed by Yoshiaki Hagiwara at Sony in 1975, show that Hagiwara invented Buried Photodiode (BPD) with the Pinned Surface Hole Accumulation, Pinned Photodiode (PPD) and Hole Accumulation Diode (HAD). It is also evident that Hagiwara invented Global Shutter Scheme of the three level clocking with MOS Capacitor Buffer Memory, clearly shown in JPA 1975-127646 and JPA 1975-127647. It is also evident that Hagiwara et al invented the Electrical Shutter Clocking Scheme by controlling punch-thru action of the in-pixel overflow drain (OFD) voltage as evidenced in JPA 1977-136885.

Hagiwara in 1975 invented PPD with VOD and the virtual charge transfer. Study the Japanese Patents 1975-127646, 1975-127647 and 1975-134985.

Difference of Pinned Photodiode and Buried Photodiode

Pinned Photodiode must have the P+ heavy doped channel stops nearby.

Pinned Photodiode must be a buried photodiode.

Pinned Photodiode must not have the edge barrier to the Charge Transfer Gate

Pinned Buried Photodiode
does not have the edge barrier

Buried Photodiode
with the edge barrier

Bucket Brigade Device (BBD)
with Serious Image Lag

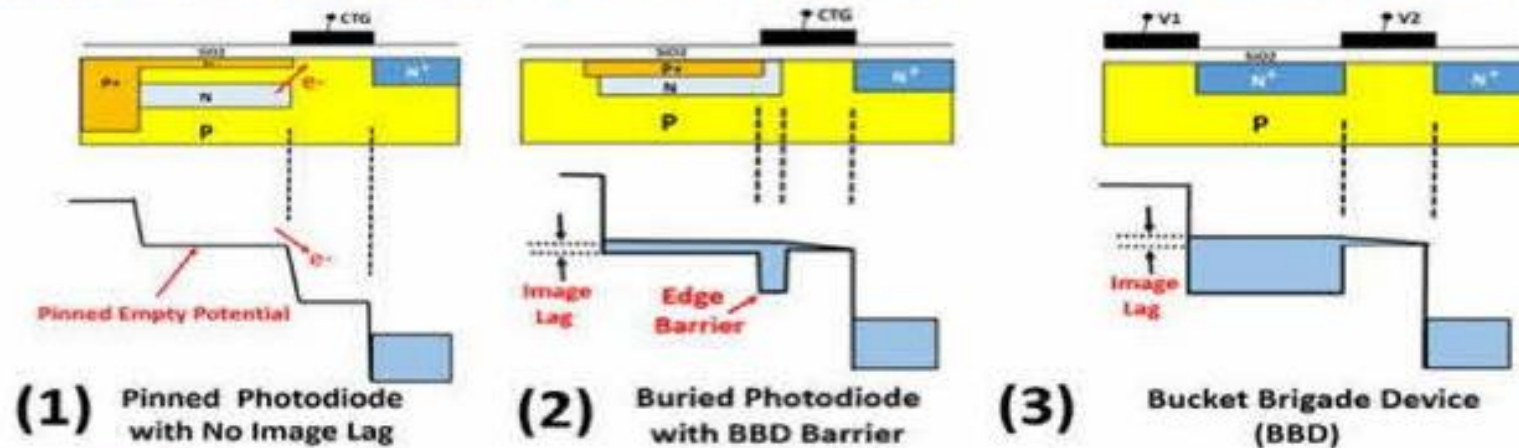

The surface P+ region may not be pinned, being isolated from the LOCOS P+ channel stop region by the buried N storage region.

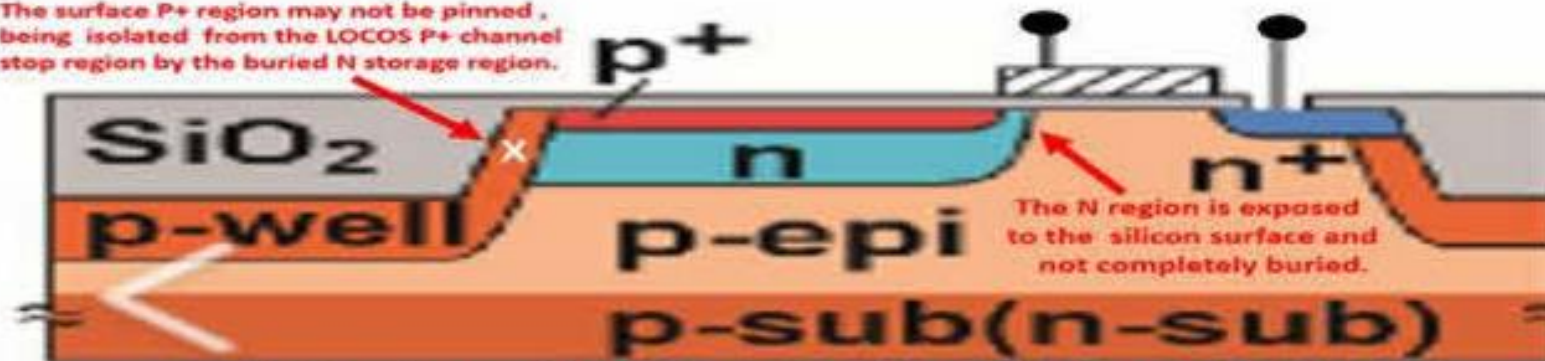

This photodiode is not Pinned Photodiode since the N storage region is not completely buried.

Hagiwara invented Pinned Photodiode (PPD).

Japanese Patent Applications, JPA1975-127646, JPA1975-127647 and JPA 1975-134985, filed by Yoshiaki Hagiwara at Sony in 1975, show that Hagiwara invented Buried Photodiode (BPD) with the Pinned Surface Hole Accumulation, Pinned Photodiode (PPD) and Hole Accumulation Diode (HAD). It is also evident that Hagiwara invented Global Shutter Scheme of the three level clocking with MOS Capacitor Buffer Memory, clearly shown in JPA 1975-127646 and JPA 1975-127647. It is also evident that Hagiwara et al invented the Electrical Shutter Clocking Scheme by controlling punch-thru action of the in-pixel overflow drain (OFD) voltage as evidenced in JPA 1977-136885.

Albert J.P. Theuwissen, Jan T.J. Bosiers, Edwin Roks, "The Hole Role", an invited paper at IEDM2005, Washington DC, Techn. Dig. , 2005.

But in the case that parts of the depleted n-type CCD channels are not covered by gate material, their surface potential is undefined ! Such a structure will suffer from charge transport issues during operation, because charge can be trapped in local potential pockets. The effect can be solved by defining the potential in the open areas through an extension of the p⁺ channel stopper. A simple self-aligned implant of 2×10^{13} /cm² boron ions is sufficient to extend the channel stop areas to the gate edge and consequently fix the potential in the open areas [2]. The result after this self-aligned implant is shown in Figure 3. The presence of enough holes plays a crucial role in fixing the potential for the regions "beyond control" of the gates. (Is this structure the mother of the pinned-photodiode or buried diode or hole-accumulation device ?)

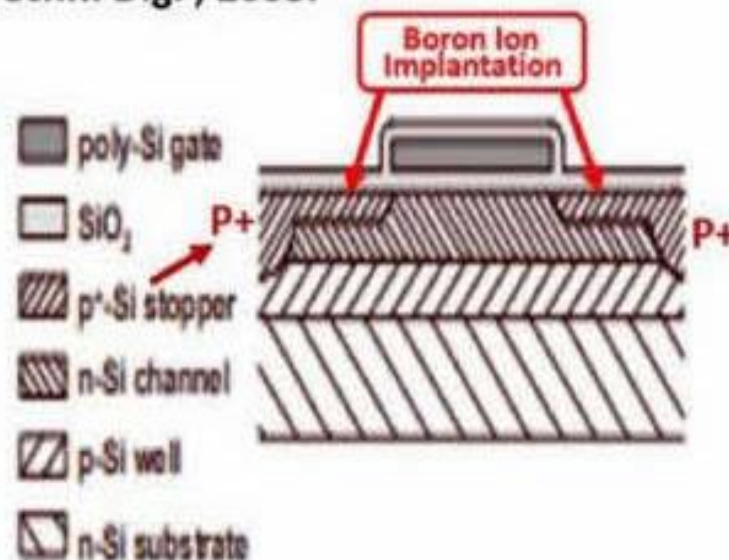

Figure 3. Cross section of a buried-channel CCD on n-Si substrate including light windows and pinned interface potential in the non-covered CCD channels (the cross section is made perpendicular to the CCD channel).

[2] Y. Daimon-Hagiwara et.al., Proc. 10th Conf. on Solid-State Devices, Tokyo, 1978, pp.335-340,

Hagiwara invented Pinned Photodiode (PPD).

Japanese Patent Applications, JPA1975-127646, JPA1975-127647 and JPA 1975-134985, filed by Yoshiaki Hagiwara at Sony in 1975, show that Hagiwara invented Buried Photodiode (BPD) with the Pinned Surface Hole Accumulation, Pinned Photodiode (PPD) and Hole Accumulation Diode (HAD). It is also evident that Hagiwara invented Global Shutter Scheme of the three level clocking with MOS Capacitor Buffer Memory, clearly shown in JPA 1975-127646 and JPA 1975-127647. It is also evident that Hagiwara et al invented the Electrical Shutter Clocking Scheme by controlling punch-thru action of the in-pixel overflow drain (OFD) voltage as evidenced in JPA 1977-136885.

Difference between Buried Photodiode and Pinned Photodiode

What is the difference between Buried Photodiode and Pinned Photodiode? I understand that the P+/N/P structure where the P+ and P layers have the same potential is the Pinned Photodiode. So what is the buried Photodiode?

<https://electronics.stackexchange.com/questions/83018/difference-between-buried-photodiode-and-pinned-photodiode>

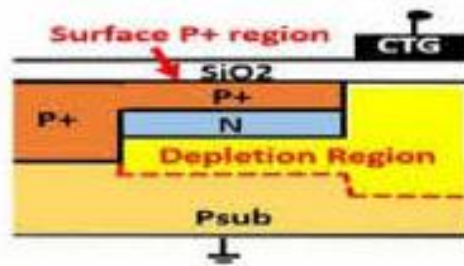

In 1975 the first PPD was invented by Hagiwara at Sony and used in ILT CCD PDs by Hamazaki at Sony in 1987.

PPD must have the P+ channel stops nearby to pin the surface P+ layer.

This is a commonly misunderstood misused set of terminologies.

First off these are not PIN Photodiodes - which stands for P - Intrinsic - N. These have large depletion regions for higher internal QE (Quantum Efficiency) and faster response. You can't make an array with this design though.

Pinning, refers to fermi-level pinning or pinning to a certain voltage level. Or also the forcing or prevention of the fermi-level/voltage from moving in energy space.

You can get surface state pinning from the dangling Si/SiO₂ bonds providing trapping centers. A buried PD (Photodiode) has a shallow implant that forces the charge carriers away from these surface traps. The Si/SiO₂ surface contributes to increased leakage (dark current) and noise (particularly 1/f noise from trapping/de-trapping). So confusingly a buried PD avoids pinning of the fermi-level at the surface.

A pinned PD is by necessity a buried PD, but not all buried PD's are pinned. The first Pinned PD was invented by Hagiwara at Sony and is used in ILT CCD PD's, these same PD's and the principles behind this complete transfer of charge are used in most CMOS imagers built today.

A pinned PD is designed to have the collection region deplete out when reset. AS the PD depletes it becomes disconnected from the readout circuit and if designed properly will drain all charge out of the collection region (accomplishing complete charge transfer). An interesting side effect is that the capacitance of the PD drops to effectively zero and therefore the KTC noise $q_n = \sqrt{KTC}$ also goes to zero. When you design the depletion of the PD to deplete at a certain voltage you are pinning that PD to that voltage. That is where the term comes from.

I've edited this Answer to acknowledge Hagiwara-san's contribution. It has long been incorrectly attributed to Teranishi and to Fossum (in CMOS image sensors)

Hagiwara invented Pinned Photodiode (PPD).

Japanese Patent Applications, JPA1975-127646, JPA1975-127647 and JPA 1975-134985, filed by Yoshiaki Hagiwara at Sony in 1975, show that Hagiwara invented Buried Photodiode (BPD) with the Pinned Surface Hole Accumulation, Pinned Photodiode (PPD) and Hole Accumulation Diode (HAD). It is also evident that Hagiwara invented Global Shutter Scheme of the three level clocking with MOS Capacitor Buffer Memory, clearly shown in JPA 1975-127646 and JPA 1975-127647. It is also evident that Hagiwara et al invented the Electrical Shutter Clocking Scheme by controlling punch-thru action of the in-pixel overflow drain (OFD) voltage as evidenced in JPA 1977-136885.

Semiconductor History Museum of Japan

<https://www.shmj.or.jp/english/pdf/dis/exhibi1005E>.

In 1975, Sony proposed using a PNP transistor as the photodetector [3]. By providing a P + layer (emitter) for the light incident section, the sensor electrode that covers the entire light receiving surface of the photodiode can be eliminated, greatly improving the light sensitivity. This P + layer was also a proposal to reduce the dark current and image lag which became the basis of the pinned photodiode.

In 1978, Sony presented a 93,000-pixel FT (Frame Transfer) -CCD image sensor compliant with the Analog TV Broadcasting Standard (SDTV) for the first time in the world [5], using the photodiode with the same structure as above. Sony succeeded in 1981 in trial production of a VTR-integrated color movie camera using a 2 / 3-inch 280,000-pixel FT-CCD image sensor by further improvement of this technology [6].

The Pinned Photodiode is a photodiode in which the entire N layer is covered with a P layer. The part of the P layer on the light incident surface is heavily doped P+ (Fig-1). Kodak named this structure Pinned Photodiode in 1984 because the P + surface of the light incident surface was pinned to the substrate potential. This device has features such as high light sensitivity, wide dynamic range, image lag free, much smaller dark current due to reduced influence of GR center on the light receiving surface, and no white scars.

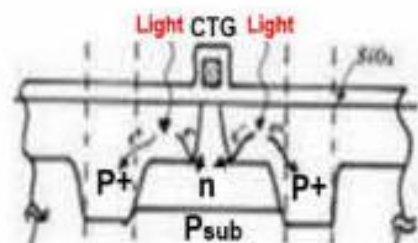

Pinned Photodiode reported at SSDM 1978

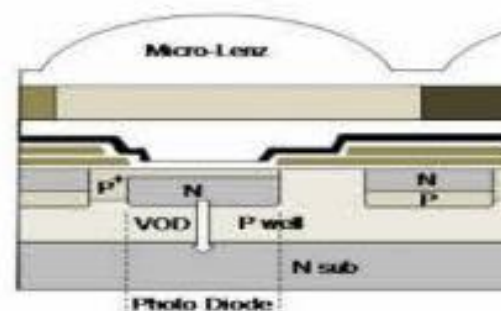
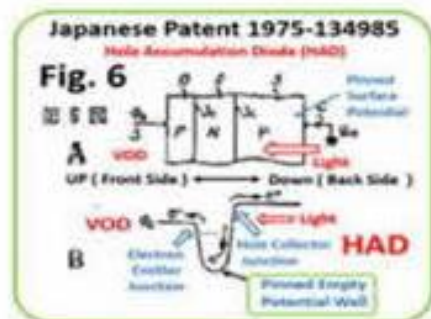

References:

- [1] M. Hamasaki, T. Suzuki, Y. Kagawa, K. Ishikawa, K. Miyata and H. Kambe, "An IT-CCD imager with electronically variable shutter speed", Technical Report of The Institute of Image Information and Television Engineers, vol. 12, no. 12, pp. 31-36, (1988)
- [3] Y. Hagiwara, Japanese Patent JP1975-134985
- [5] Y. Hagiwara, M. Abe, and C. Okada, "A 380H x 488V CCD imager with narrow channel transfer gates", Proc. The 10th Conference on Solid State Devices, Tokyo, (1978); Japanese Journal of Applied Physics, vol. 18, Supplements 18-1, pp. 335-340, (1979)
- [6] I. Kajino, M. Shimada, Y. Nakada, Y. Hirata and Y. Hagiwara, "Single Chip Color Camera Using Narrow channel CCD Imager with Over Flow Drain", Technical Report of The Institute of Image Information and Television Engineers, vol. 5, no. 29, pp.

Hagiwara invented Pinned Photodiode (PPD).

Japanese Patent Applications, JPA1975-127646, JPA1975-127647 and JPA 1975-134985, filed by Yoshiaki Hagiwara at Sony in 1975, show that Hagiwara invented Buried Photodiode (BPD) with the Pinned Surface Hole Accumulation, Pinned Photodiode (PPD) and Hole Accumulation Diode (HAD). It is also evident that Hagiwara invented Global Shutter Scheme of the three level clocking with MOS Capacitor Buffer Memory, clearly shown in JPA 1975-127646 and JPA 1975-127647. It is also evident that Hagiwara et al invented the Electrical Shutter Clocking Scheme by controlling punch-thru action of the in-pixel overflow drain (OFD) voltage as evidenced in JPA 1977-136885.

Sony's Representative Inventions Supporting Stacked Multi-Functional CMOS Image Sensors

Sony Corporation

Sony Semiconductor Solutions Corporation

<https://www.sony.net/SonyInfo/News/notice/20200626/>

Pinned Photodiode Adopted for Back-Illuminated CMOS Image Sensors

The history of Sony's inventions of image sensors goes back to the CCD era. Above all, Pinned Photodiode is a technology that contributes to improving the performance of back-illuminated CMOS image sensors, and the history of inventions and product development are as below.

In 1975, Sony invented a CCD image sensor that adopted a back-illuminated N+NP+N junction type and an N+NP+NP junction type Pinned Photodiode (PPD) (Japanese patent application number 1975-127646, 1975-127647 [Yoshiaki Hagiwara](#)). In the same year, inspired by such structure, Sony invented a PNP junction type PPD with VOD (vertical overflow drain) function (Japanese Patent No. 1215101 [Yoshiaki Hagiwara](#)). After that, Sony succeeded in making a principle prototype of a frame transfer CCD image sensor that adopted the PNP junction type PPD technology, having a high-impurity-concentration P+ channel stop region formed near a light receiving section by ion implantation technology for the first time in the world, and its technical paper was presented at the academic conference, SSDM 1978 ([Y. Hagiwara](#), M. Abe, and C. Okada, "A 380H x 488V CCD imager with narrow channel transfer gates", Proc. The 10th Conference on Solid State Devices, Tokyo, (1978)). In 1980, Sony succeeded in making a camera integrated VTR which incorporated a one-chip frame transfer CCD image sensor that adopted the PNP junction type PPD. President Iwama in Tokyo, Chairperson Morita in New York, at the time held a press conference respectively on the same day, which surprised the world. In 1987, Sony succeeded in developing a 8 mm video camcorder that adopted, for the first time in the world, the interline transfer CCD image sensor, which incorporated "PPD having a high-impurity-concentration P+ channel stop region formed near the light receiving section by ion implantation technology" with VOD function, and became the pioneer of the video camera market. The PPD technology that has been nurtured through such a long history is still used in back-illuminated CMOS image sensors.

References:

- [1] M. Hamasaki, T. Suzuki, Y. Kagawa, K. Ishikawa, K. Miyata and H. Kambe, "An IT-CCD imager with electronically variable shutter speed", Technical Report of The Institute of Image Information and Television Engineers, vol. 12, no. 12, pp. 31-36, (1988)
- [3] [Y. Hagiwara](#), Japanese Patent JP1975-134985
- [5] [Y. Hagiwara](#), M. Abe, and C. Okada, "A 380H x 488V CCD imager with narrow channel transfer gates", Proc. The 10th Conference on Solid State Devices, Tokyo, (1978); Japanese Journal of Applied Physics, vol. 18, Supplements 18-1, pp. 335-340, (1979)
- [6] I. Kajino, M. Shimada, Y. Nakada, Y. Hirata and [Y. Hagiwara](#), "Single Chip Color Camera Using Narrow channel CCD Imager with Over Flow Drain", Technical Report of The Institute of Image Information and Television Engineers, vol. 5, no. 29, pp.

Hagiwara invented Pinned Photodiode (PPD).

Japanese Patent Applications, JPA1975-127646, JPA1975-127647 and JPA 1975-134985, filed by Yoshiaki Hagiwara at Sony in 1975, show that Hagiwara invented Buried Photodiode (BPD) with the Pinned Surface Hole Accumulation, Pinned Photodiode (PPD) and Hole Accumulation Diode (HAD). It is also evident that Hagiwara invented Global Shutter Scheme of the three level clocking with MOS Capacitor Buffer Memory, clearly shown in JPA 1975-127646 and JPA 1975-127647. It is also evident that Hagiwara et al invented the Electrical Shutter Clocking Scheme by controlling punch-thru action of the in-pixel overflow drain (OFD) voltage as evidenced in JPA 1977-136885.

Finally the Sony-Fairchild Patent War(1991-2000) ended over the Sony HAD Sensor which is identical to the P+NPNsub junction type Pinned Photodiode with Vertical Overflow Drain, originally invented by Hagiwara at Sony in 1975.

And finally Hagiwara received for his 1975-134985 Japanese Patent officially, the First Patent Award from Mr. Ando, Sony president in April, 2001 after more 26 years of struggles since his invention.

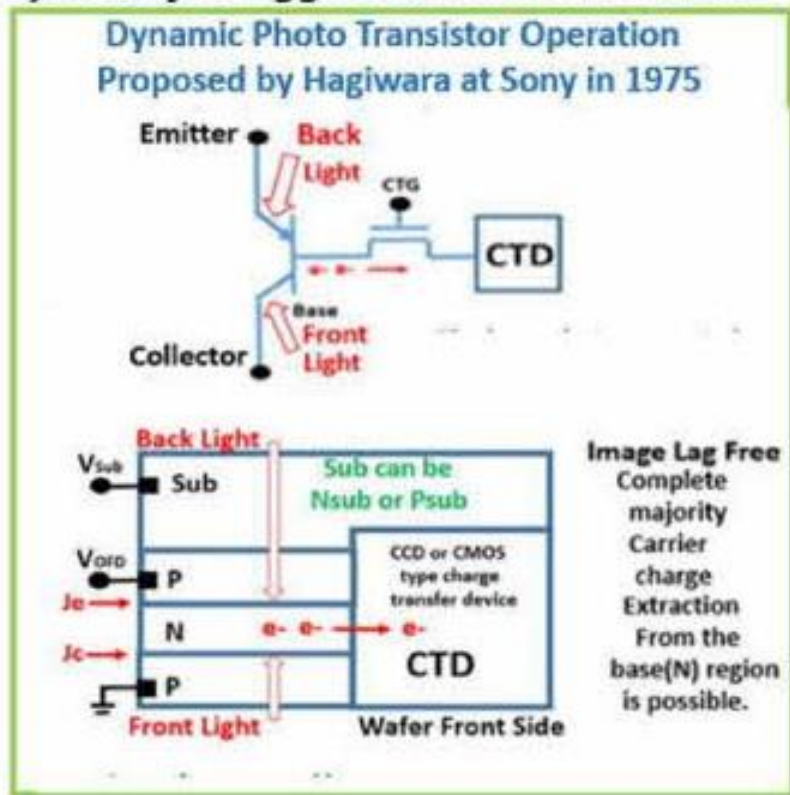

Hagiwara invented Pinned Photodiode (PPD).

Japanese Patent Applications, JPA1975-127646, JPA1975-127647 and JPA 1975-134985, filed by Yoshiaki Hagiwara at Sony in 1975, show that Hagiwara invented Buried Photodiode (BPD) with the Pinned Surface Hole Accumulation, Pinned Photodiode (PPD) and Hole Accumulation Diode (HAD). It is also evident that Hagiwara invented Global Shutter Scheme of the three level clocking with MOS Capacitor Buffer Memory, clearly shown in JPA 1975-127646 and JPA 1975-127647. It is also evident that Hagiwara et al invented the Electrical Shutter Clocking Scheme by controlling punch-thru action of the in-pixel overflow drain (OFD) voltage as evidenced in JPA 1977-136885.

The Pinned Photodiode (Sony Original HAD sensor) Structure

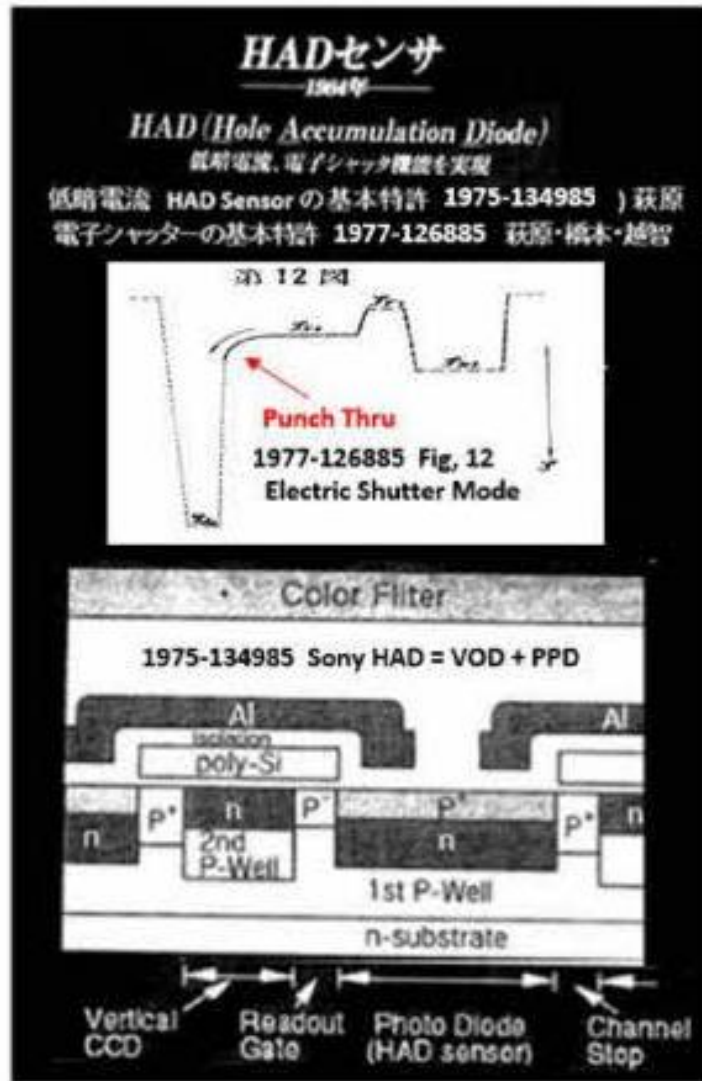

(from SONY Product Catalog)

Electric Shutter Basic Patent Award
from Sony President Idei to Yoshiaki Hagiwara
for Japanese Patent 1977-126885 by Hagiwara



Hagiwara invented Pinned Photodiode (PPD).

Japanese Patent Applications, JPA1975-127646, JPA1975-127647 and JPA 1975-134985, filed by Yoshiaki Hagiwara at Sony in 1975, show that Hagiwara invented Buried Photodiode (BPD) with the Pinned Surface Hole Accumulation, Pinned Photodiode (PPD) and Hole Accumulation Diode (HAD). It is also evident that Hagiwara invented Global Shutter Scheme of the three level clocking with MOS Capacitor Buffer Memory, clearly shown in JPA 1975-127646 and JPA 1975-127647. It is also evident that Hagiwara et al invented the Electrical Shutter Clocking Scheme by controlling punch-thru action of the in-pixel overflow drain (OFD) voltage as evidenced in JPA 1977-136885.

The N+PNP junction type Dynamic Photo Transistor Structure
 Pinned Photodiode and Sony Hole Accumulation Diode (HAD)
 with the vertical overflow drain (VOD) function
 invented by Hagiwara at Sony in 1975

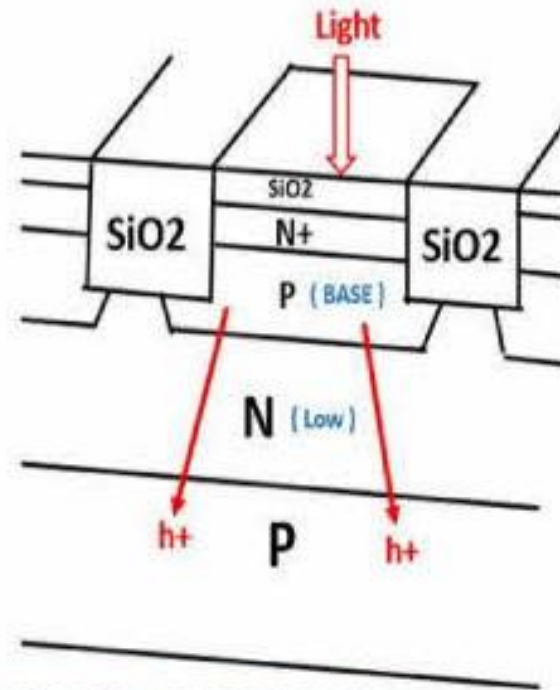
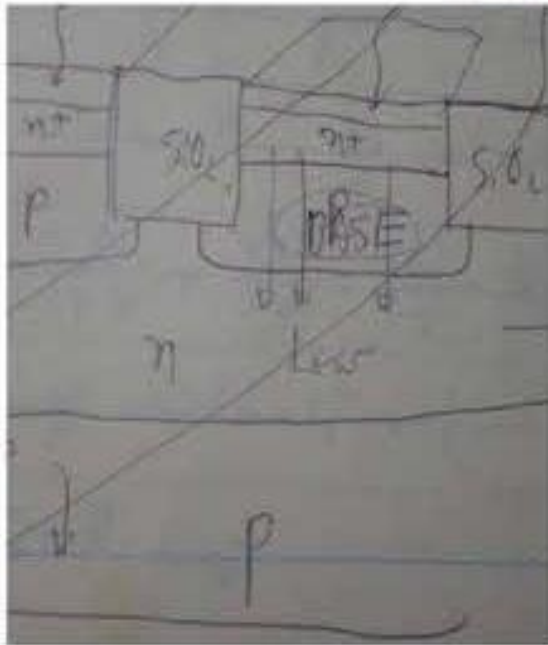

Hagiwara's Lab Note at Sony in February 1975

In 1975 at Sony, Yoshiaki Hagiwara filed three Japanese patents JPA1975-127646, JPA1975-127647 and JPA1975-134985 on the Pinned Surface Photodiode with the VOD function which is later called as Sony Hole Accumulation Diode (HAD). Hagiwara did not file a patent on the SiO2 device isolation but this lab note shows that Hagiwara had an idea of forming the Shallow Trench Isolation by the Local Oxidation Method, which was hinted by the LOCOS isolation in 1970s.

Hagiwara invented Pinned Photodiode (PPD).

Japanese Patent Applications, JPA1975-127646, JPA1975-127647 and JPA 1975-134985, filed by Yoshiaki Hagiwara at Sony in 1975, show that Hagiwara invented Buried Photodiode (BPD) with the Pinned Surface Hole Accumulation, Pinned Photodiode (PPD) and Hole Accumulation Diode (HAD). It is also evident that Hagiwara invented Global Shutter Scheme of the three level clocking with MOS Capacitor Buffer Memory, clearly shown in JPA 1975-127646 and JPA 1975-127647. It is also evident that Hagiwara et al invented the Electrical Shutter Clocking Scheme by controlling punch-thru action of the in-pixel overflow drain (OFD) voltage as evidenced in JPA 1977-136885.

Pinned_Photodiode_Patents_by_Yoshiaki_Hagiwara

The following slides explain the details of 1975_Pinned_Photodiode_Patent.

Artificial Intelligent Partner System(AIPS) Home Page Top
hagiwara-yoshiaki@aiplab.com

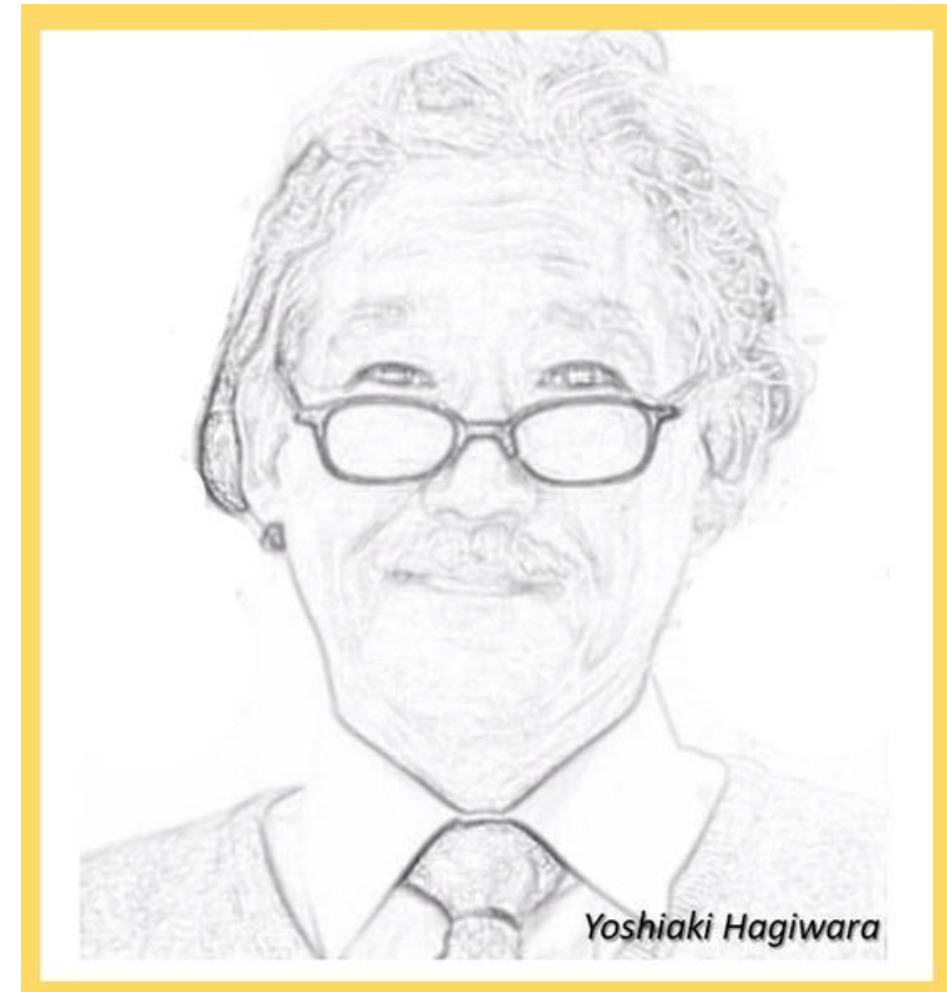

Thank You Very Much !

Image Sensor Story

Yoshiaki Hagiwara

AIPS



Hagiwara invented Pinned Photodiode (PPD).

Japanese Patent Applications, JPA1975-127646, JPA1975-127647 and JPA 1975-134985, filed by Yoshiaki Hagiwara at Sony in 1975, show that Hagiwara invented Buried Photodiode (BPD) with the Pinned Surface Hole Accumulation, Pinned Photodiode (PPD) and Hole Accumulation Diode (HAD). It is also evident that Hagiwara invented

Global Shutter Scheme of the three level clocking with MOS Capacitor Buffer Memory, clearly shown in JPA 1975-127646 and JPA 1975-127647. It is also evident that Hagiwara et al invented the Electrical Shutter Clocking Scheme by controlling punch-thru action of the in-pixel overflow drain (OFD) voltage as evidenced in JPA 1977-136885.

Image Sensor Story

Yoshiaki Hagiwara

AIPS



Hagiwara invented Pinned Photodiode (PPD).

Japanese Patent Applications, JPA1975-127646, JPA1975-127647 and JPA 1975-134985, filed by Yoshiaki Hagiwara at Sony in 1975, show that Hagiwara invented Buried Photodiode (BPD) with the Pinned Surface Hole Accumulation, Pinned Photodiode (PPD) and Hole Accumulation Diode (HAD). It is also evident that Hagiwara invented Global Shutter Scheme of the three level clocking with MOS Capacitor Buffer Memory, clearly shown in JPA 1975-127646 and JPA 1975-127647. It is also evident that Hagiwara et al invented the Electrical Shutter Clocking Scheme by controlling punch-thru action of the in-pixel overflow drain (OFD) voltage as evidenced in JPA 1977-136885.

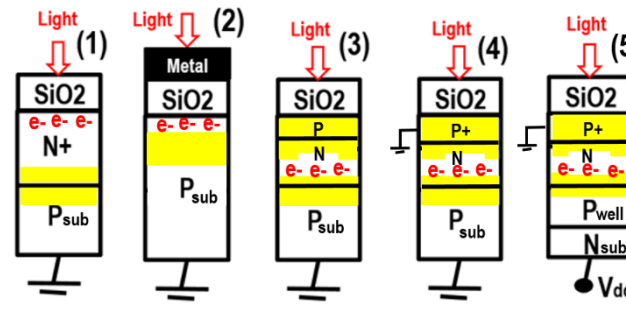
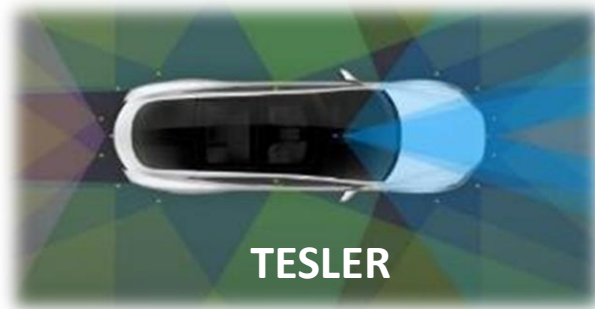

Resolution



SN Ratio



Frame Rate



Front-illuminated CIS



Dynamic Range



Shutter

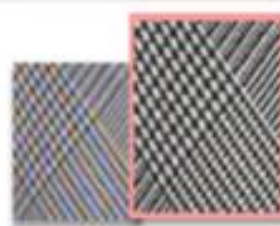

Color Reality



Back-illuminated CIS

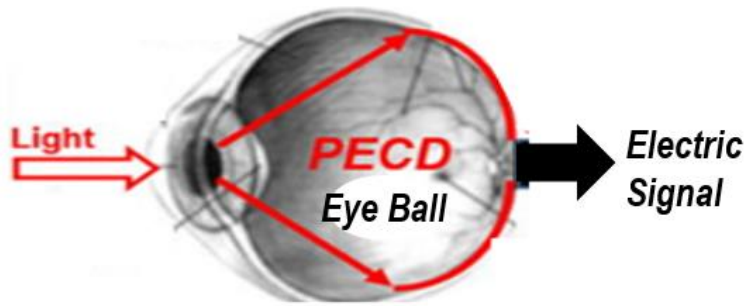

Hagiwara invented Pinned Photodiode (PPD).

Japanese Patent Applications, JPA1975-127646, JPA1975-127647 and JPA 1975-134985, filed by Yoshiaki Hagiwara at Sony in 1975, show that Hagiwara invented Buried Photodiode (BPD) with the Pinned Surface Hole Accumulation, Pinned Photodiode (PPD) and Hole Accumulation Diode (HAD). It is also evident that Hagiwara invented Global Shutter Scheme of the three level clocking with MOS Capacitor Buffer Memory, clearly shown in JPA 1975-127646 and JPA 1975-127647. It is also evident that Hagiwara et al invented the Electrical Shutter Clocking Scheme by controlling punch-thru action of the in-pixel overflow drain (OFD) voltage as evidenced in JPA 1977-136885.

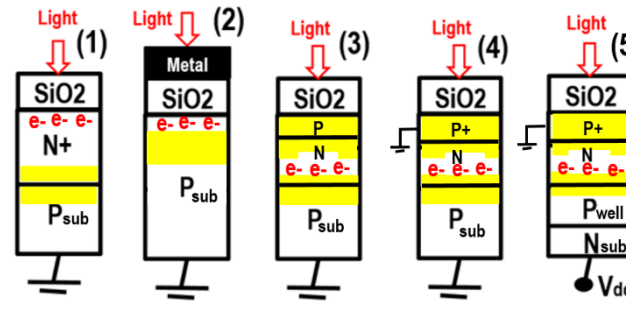

Resolution



SN Ratio



Frame Rate



Front-illuminated CIS



Dynamic Range



Shutter

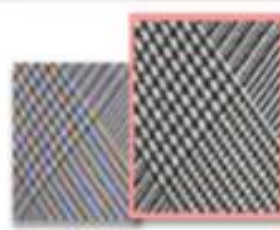

Color Reality



Back-illuminated CIS

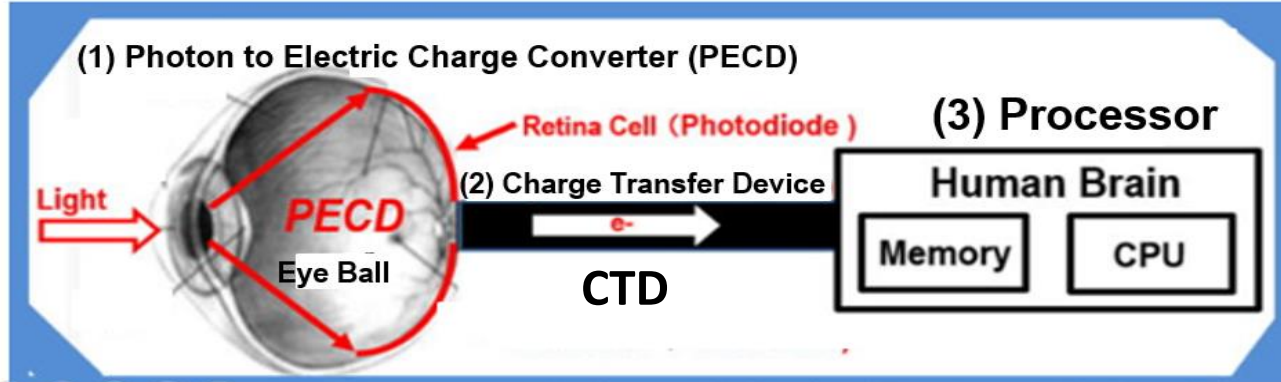

Hagiwara invented Pinned Photodiode (PPD).

Japanese Patent Applications, JPA1975-127646, JPA1975-127647 and JPA 1975-134985, filed by Yoshiaki Hagiwara at Sony in 1975, show that Hagiwara invented Buried Photodiode (BPD) with the Pinned Surface Hole Accumulation, Pinned Photodiode (PPD) and Hole Accumulation Diode (HAD). It is also evident that Hagiwara invented Global Shutter Scheme of the three level clocking with MOS Capacitor Buffer Memory, clearly shown in JPA 1975-127646 and JPA 1975-127647. It is also evident that Hagiwara et al invented the Electrical Shutter Clocking Scheme by controlling punch-thru action of the in-pixel overflow drain (OFD) voltage as evidenced in JPA 1977-136885.

Navigation icons: back, forward, search, etc.

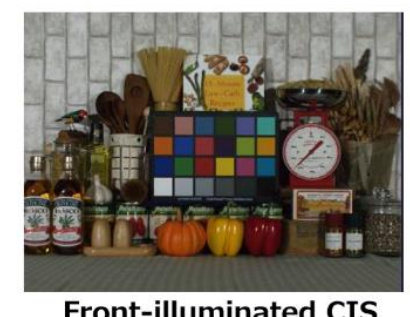
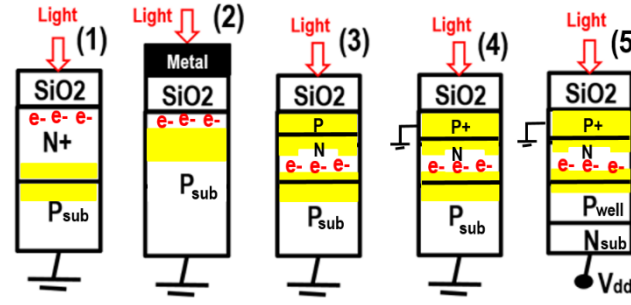

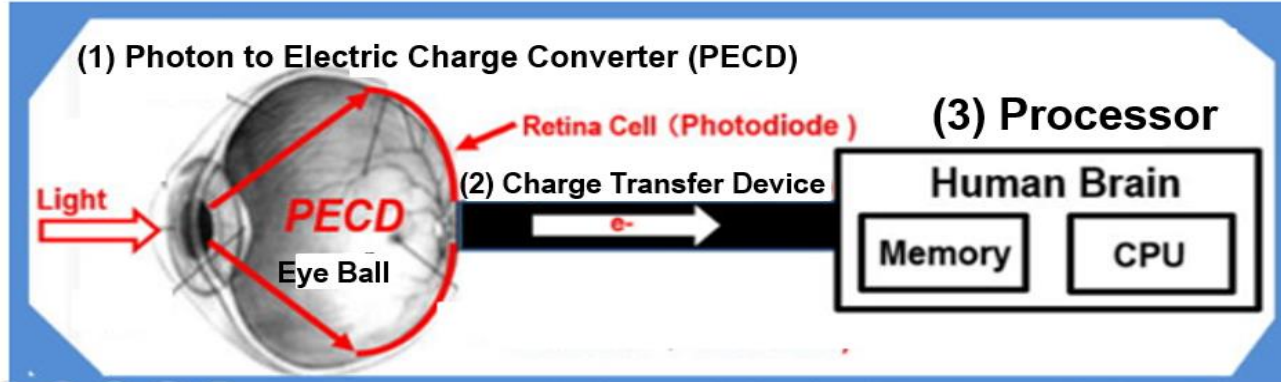

Hagiwara invented Pinned Photodiode (PPD).

Japanese Patent Applications, JPA1975-127646, JPA1975-127647 and JPA 1975-134985, filed by Yoshiaki Hagiwara at Sony in 1975, show that Hagiwara invented Buried Photodiode (BPD) with the Pinned Surface Hole Accumulation, Pinned Photodiode (PPD) and Hole Accumulation Diode (HAD). It is also evident that Hagiwara invented Global Shutter Scheme of the three level clocking with MOS Capacitor Buffer Memory, clearly shown in JPA 1975-127646 and JPA 1975-127647. It is also evident that Hagiwara et al invented the Electrical Shutter Clocking Scheme by controlling punch-thru action of the in-pixel overflow drain (OFD) voltage as evidenced in JPA 1977-136885.

(1) Photon to Electric Charge Converter (PECD)

- N+P single junction
- P+NP double junction
- P+NPN triple junction

(2) Charge Transfer Device (CTD)

- MOS type
- CCD type
- Active Pixel (In Pixel Current Amp + CDS + ADC) CMOS

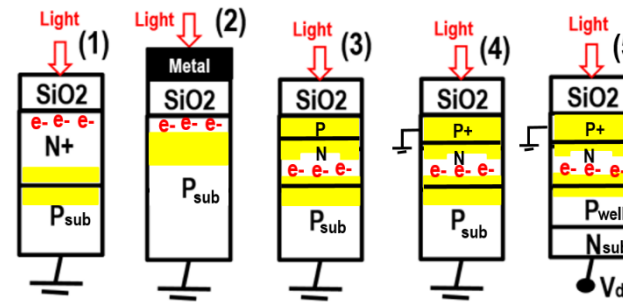

| | | |
|----------------------|-----------------|----------------------|
| | | |
| Resolution | SN Ratio | Frame Rate |
| | | |
| Dynamic Range | Shutter | Color Reality |

Front-illuminated CIS

Back-illuminated CIS

● NPN transistor Current Amplification

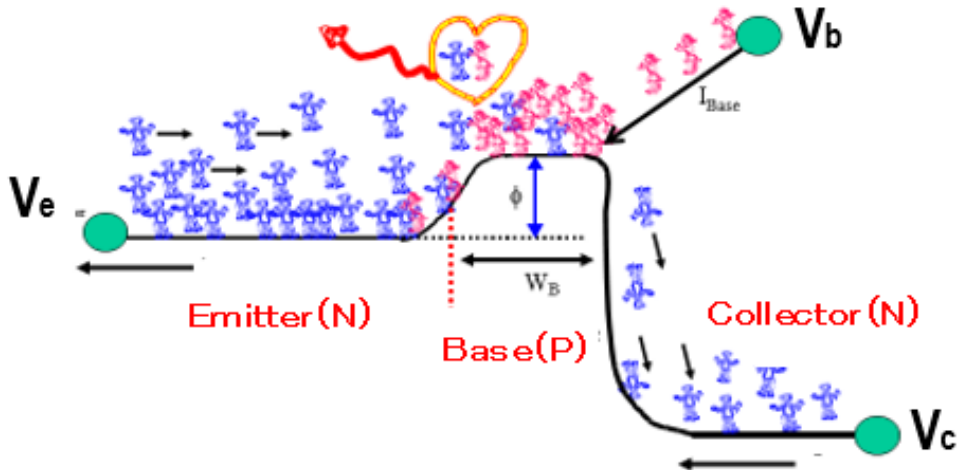

3-D Multi-chips Intelligent CMOS Image Sensor System

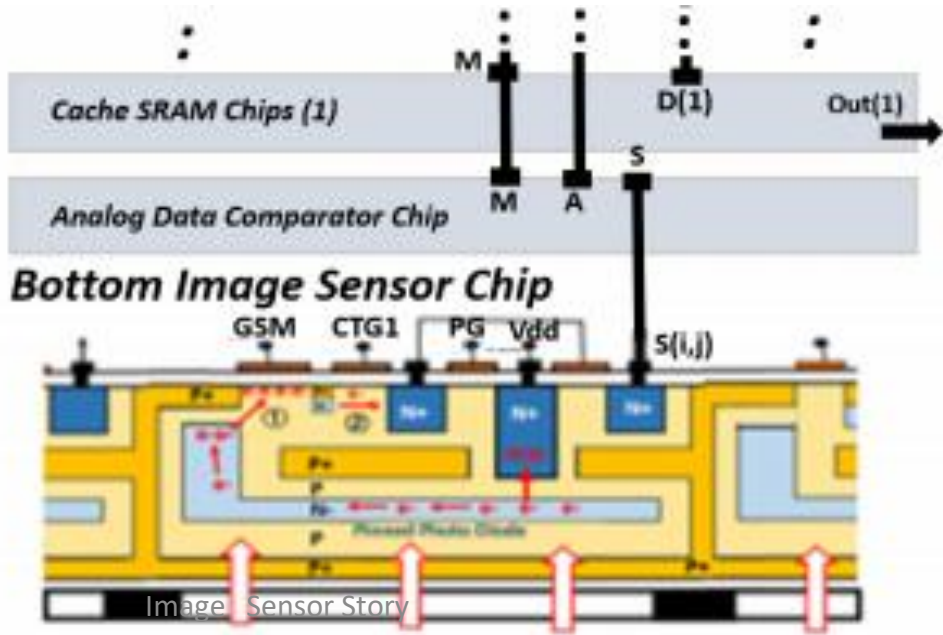

● Why CMOS is so strong ?

● Low Power CMOS inverter

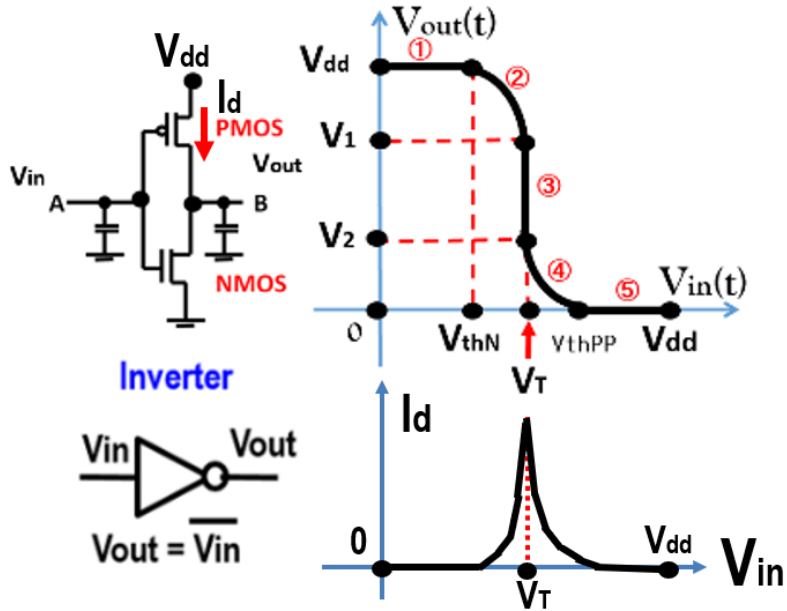

● Water Gate Model for CMOS Inverter

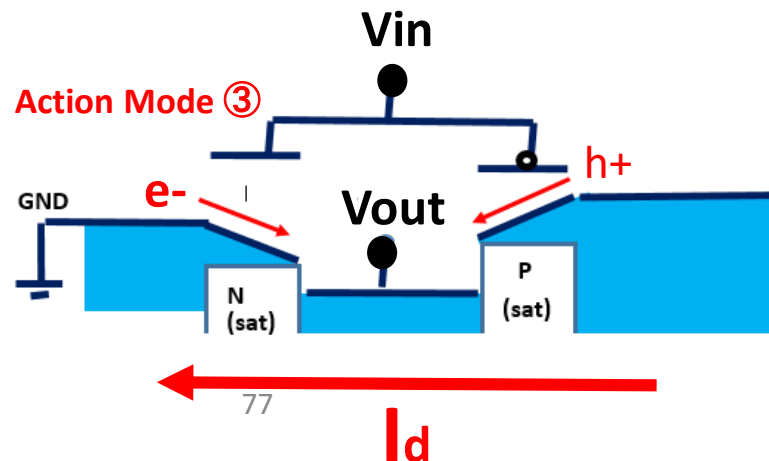

Hagiwara invented Pinned Photodiode (PPD).

Japanese Patent Applications, JPA1975-127646, JPA1975-127647 and JPA 1975-134985, filed by Yoshiaki Hagiwara at Sony in 1975, show that Hagiwara invented Buried Photodiode (BPD) with the Pinned Surface Hole Accumulation, Pinned Photodiode (PPD) and Hole Accumulation Diode (HAD). It is also evident that Hagiwara invented Global Shutter Scheme of the three level clocking with MOS Capacitor Buffer Memory, clearly shown in JPA 1975-127646 and JPA 1975-127647. It is also evident that Hagiwara et al invented the Electrical Shutter Clocking Scheme by controlling punch-thru action of the in-pixel overflow drain (OFD) voltage as evidenced in JPA 1977-136885.

Resolution

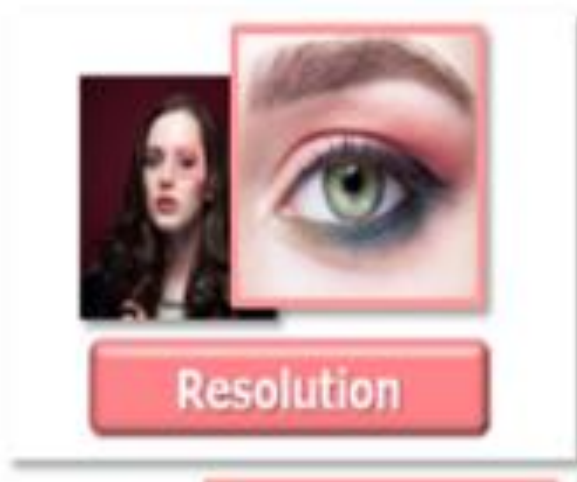

Hagiwara invented Pinned Photodiode (PPD).

Japanese Patent Applications, JPA1975-127646, JPA1975-127647 and JPA 1975-134985, filed by Yoshiaki Hagiwara at Sony in 1975, show that Hagiwara invented Buried Photodiode (BPD) with the Pinned Surface Hole Accumulation, Pinned Photodiode (PPD) and Hole Accumulation Diode (HAD). It is also evident that Hagiwara invented Global Shutter Scheme of the three level clocking with MOS Capacitor Buffer Memory, clearly shown in JPA 1975-127646 and JPA 1975-127647. It is also evident that Hagiwara et al invented the Electrical Shutter Clocking Scheme by controlling punch-thru action of the in-pixel overflow drain (OFD) voltage as evidenced in JPA 1977-136885.

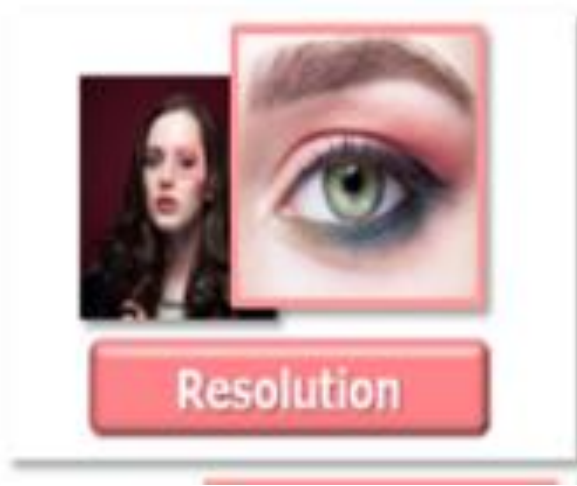

Resolution

● Analog TV
 800H x 500 V = 400,000 pixels

CCD Charge Transfer Efficiency < 99.999%

Human Eyes cannot recognize the signal loss and noise of less than 3% .

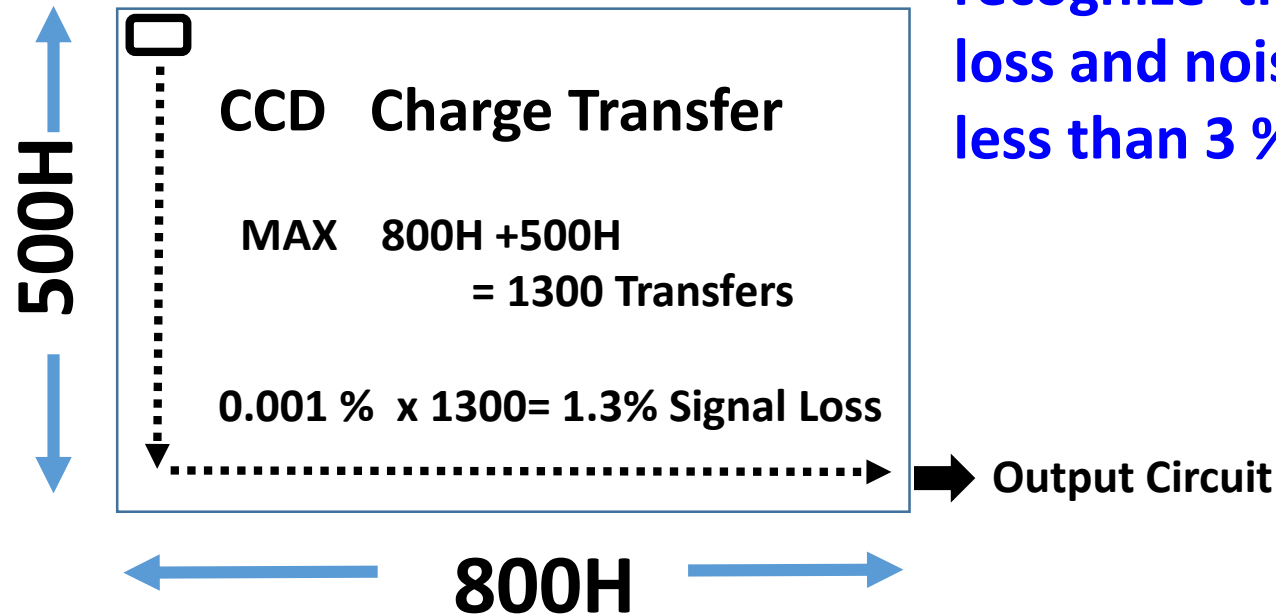

Hagiwara invented Pinned Photodiode (PPD).

Japanese Patent Applications, JPA1975-127646, JPA1975-127647 and JPA 1975-134985, filed by Yoshiaki Hagiwara at Sony in 1975, show that Hagiwara invented Buried Photodiode (BPD) with the Pinned Surface Hole Accumulation, Pinned Photodiode (PPD) and Hole Accumulation Diode (HAD). It is also evident that Hagiwara invented Global Shutter Scheme of the three level clocking with MOS Capacitor Buffer Memory, clearly shown in JPA 1975-127646 and JPA 1975-127647. It is also evident that Hagiwara et al invented the Electrical Shutter Clocking Scheme by controlling punch-thru action of the in-pixel overflow drain (OFD) voltage as evidenced in JPA 1977-136885.

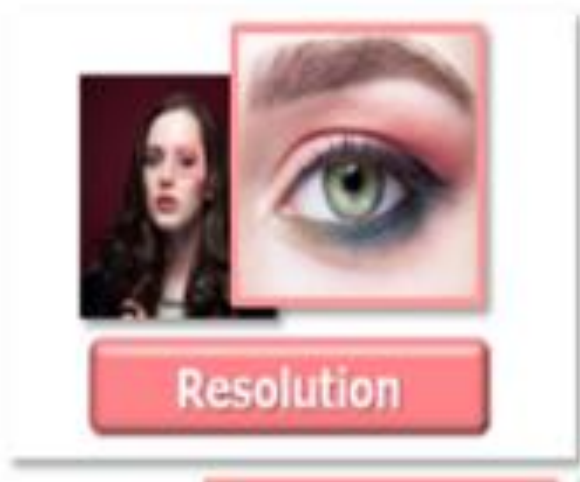

Resolution

● Digital TV

6000H x 4000 V = 24,000,000 pixel

CCD Charge Transfer Efficiency < 99.999%

Human Eyes cannot recognize the signal loss and noise of less than 3 % .

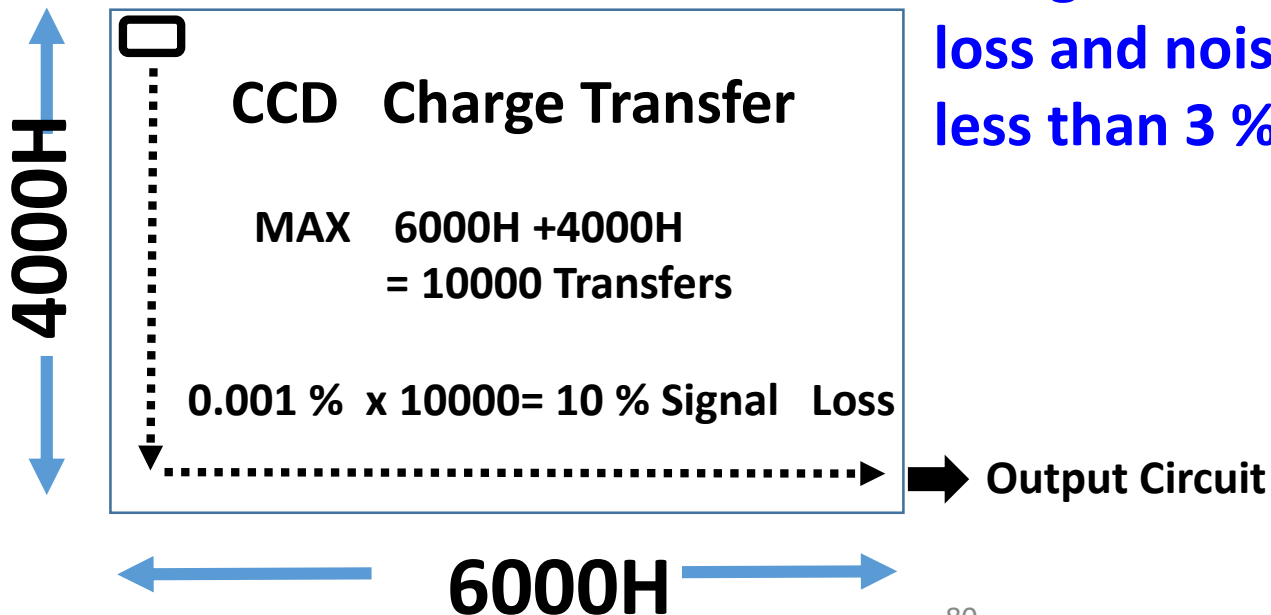

Hagiwara invented Pinned Photodiode (PPD).

Japanese Patent Applications, JPA1975-127646, JPA1975-127647 and JPA 1975-134985, filed by Yoshiaki Hagiwara at Sony in 1975, show that Hagiwara invented Buried Photodiode (BPD) with the Pinned Surface Hole Accumulation, Pinned Photodiode (PPD) and Hole Accumulation Diode (HAD). It is also evident that Hagiwara invented Global Shutter Scheme of the three level clocking with MOS Capacitor Buffer Memory, clearly shown in JPA 1975-127646 and JPA 1975-127647. It is also evident that Hagiwara et al invented the Electrical Shutter Clocking Scheme by controlling punch-thru action of the in-pixel overflow drain (OFD) voltage as evidenced in JPA 1977-136885.

Resolution



Resolution



SN Ratio



Frame Rate



Dynamic Range



Shutter

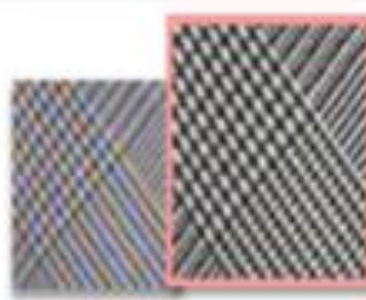

Color Reality

Hagiwara invented Pinned Photodiode (PPD).

Japanese Patent Applications, JPA1975-127646, JPA1975-127647 and JPA 1975-134985, filed by Yoshiaki Hagiwara at Sony in 1975, show that Hagiwara invented Buried Photodiode (BPD) with the Pinned Surface Hole Accumulation, Pinned Photodiode (PPD) and Hole Accumulation Diode (HAD). It is also evident that Hagiwara invented Global Shutter Scheme of the three level clocking with MOS Capacitor Buffer Memory, clearly shown in JPA 1975-127646 and JPA 1975-127647. It is also evident that Hagiwara et al invented the Electrical Shutter Clocking Scheme by controlling punch-thru action of the in-pixel overflow drain (OFD) voltage as evidenced in JPA 1977-136885.

S/N Ratio



Resolution



SN Ratio



Frame Rate



Dynamic Range



Shutter

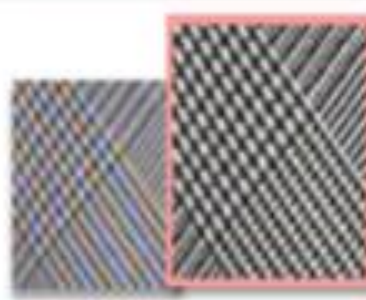

Color Reality

Hagiwara invented Pinned Photodiode (PPD).

Japanese Patent Applications, JPA1975-127646, JPA1975-127647 and JPA 1975-134985, filed by Yoshiaki Hagiwara at Sony in 1975, show that Hagiwara invented Buried Photodiode (BPD) with the Pinned Surface Hole Accumulation, Pinned Photodiode (PPD) and Hole Accumulation Diode (HAD). It is also evident that Hagiwara invented Global Shutter Scheme of the three level clocking with MOS Capacitor Buffer Memory, clearly shown in JPA 1975-127646 and JPA 1975-127647. It is also evident that Hagiwara et al invented the Electrical Shutter Clocking Scheme by controlling punch-thru action of the in-pixel overflow drain (OFD) voltage as evidenced in JPA 1977-136885.

Frame Rate

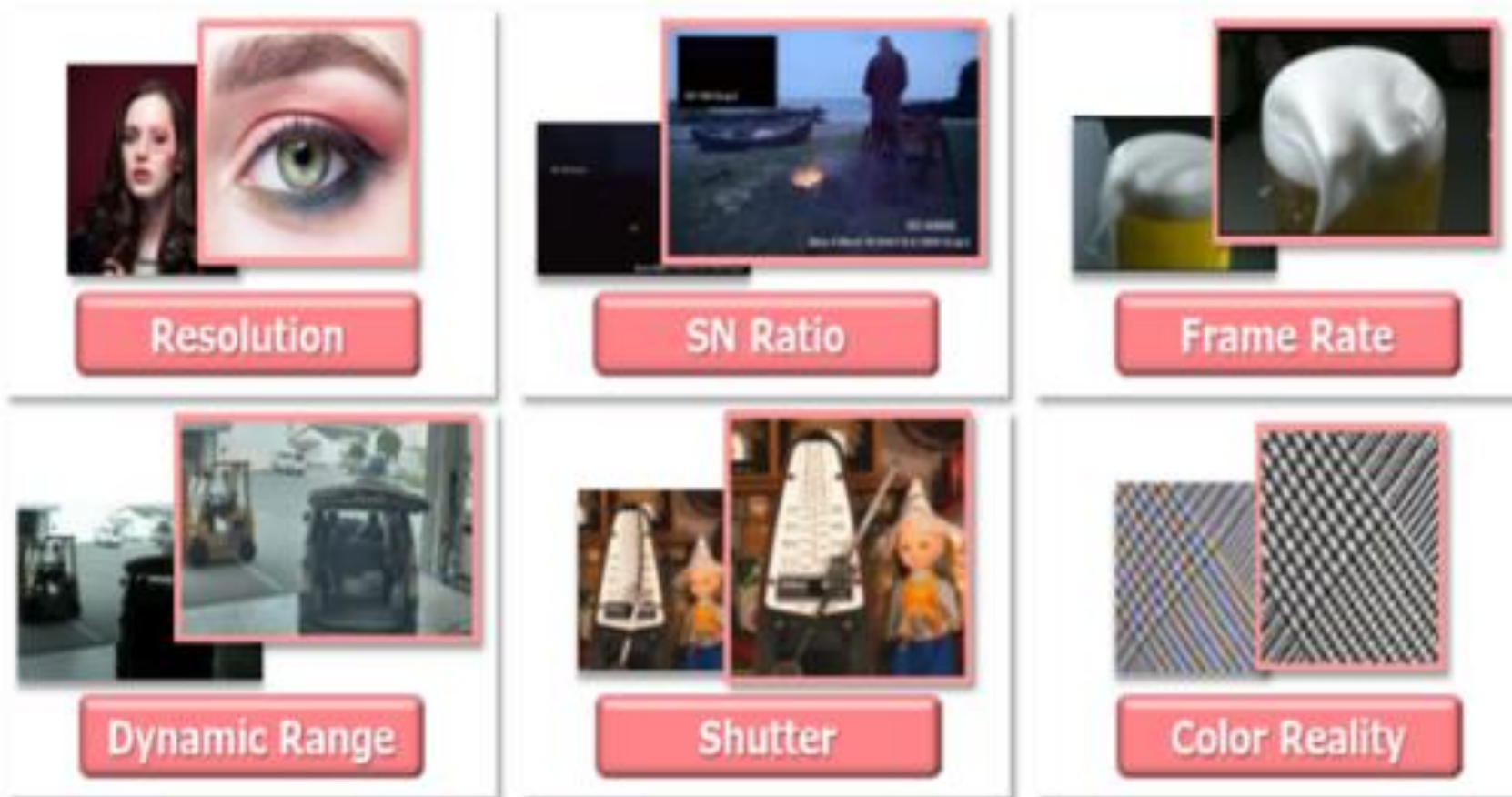

Hagiwara invented Pinned Photodiode (PPD).

Japanese Patent Applications, JPA1975-127646, JPA1975-127647 and JPA 1975-134985, filed by Yoshiaki Hagiwara at Sony in 1975, show that Hagiwara invented Buried Photodiode (BPD) with the Pinned Surface Hole Accumulation, Pinned Photodiode (PPD) and Hole Accumulation Diode (HAD). It is also evident that Hagiwara invented Global Shutter Scheme of the three level clocking with MOS Capacitor Buffer Memory, clearly shown in JPA 1975-127646 and JPA 1975-127647. It is also evident that Hagiwara et al invented the Electrical Shutter Clocking Scheme by controlling punch-thru action of the in-pixel overflow drain (OFD) voltage as evidenced in JPA 1977-136885.

Dynamic Range

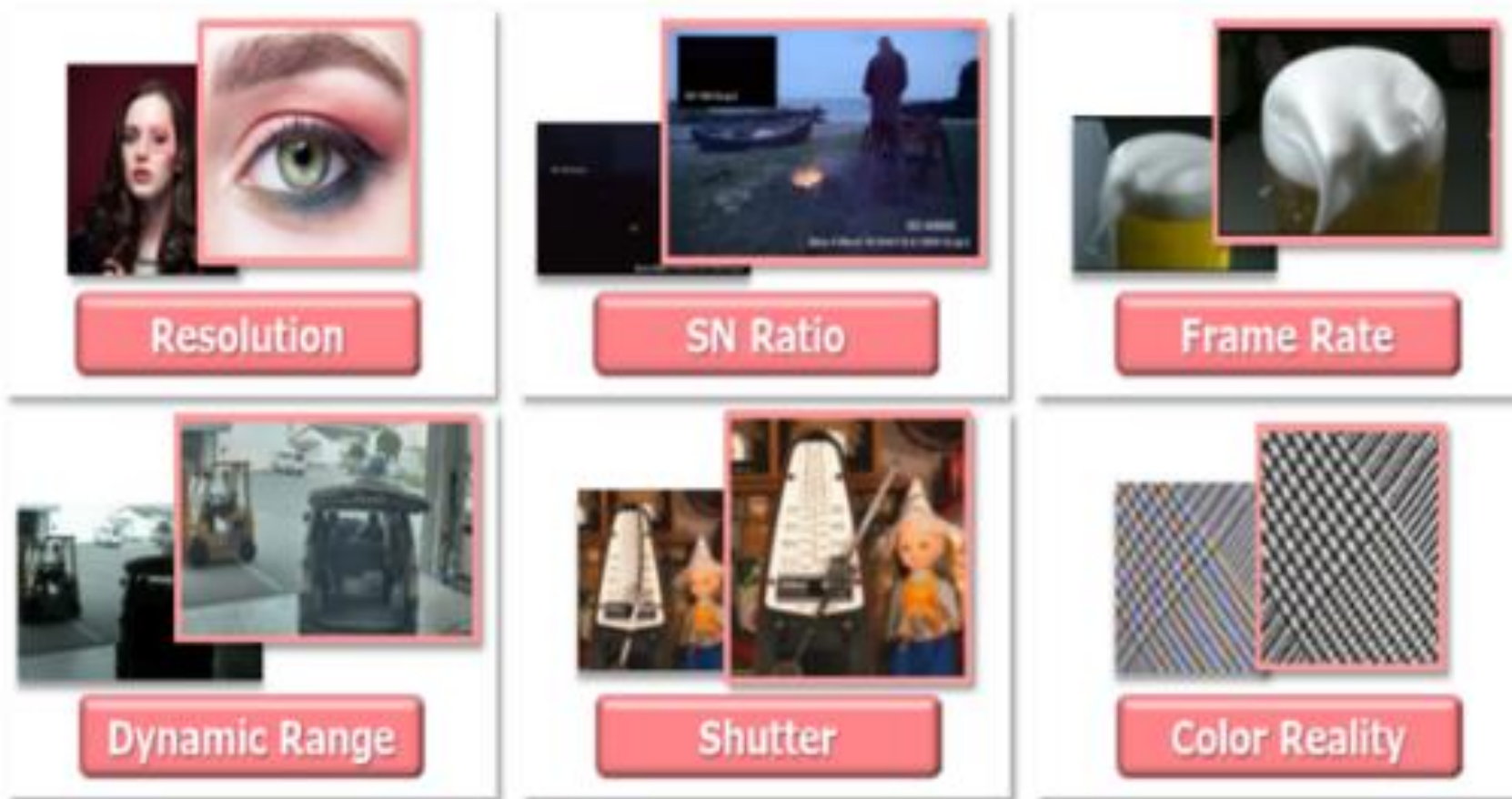

Hagiwara invented Pinned Photodiode (PPD).

Japanese Patent Applications, JPA1975-127646, JPA1975-127647 and JPA 1975-134985, filed by Yoshiaki Hagiwara at Sony in 1975, show that Hagiwara invented Buried Photodiode (BPD) with the Pinned Surface Hole Accumulation, Pinned Photodiode (PPD) and Hole Accumulation Diode (HAD). It is also evident that Hagiwara invented Global Shutter Scheme of the three level clocking with MOS Capacitor Buffer Memory, clearly shown in JPA 1975-127646 and JPA 1975-127647. It is also evident that Hagiwara et al invented the Electrical Shutter Clocking Scheme by controlling punch-thru action of the in-pixel overflow drain (OFD) voltage as evidenced in JPA 1977-136885.

Shutter



Resolution



SN Ratio



Frame Rate



Dynamic Range



Shutter

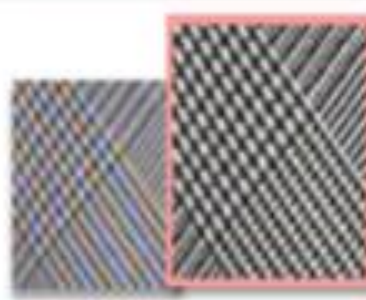

Color Reality

Hagiwara invented Pinned Photodiode (PPD).

Japanese Patent Applications, JPA1975-127646, JPA1975-127647 and JPA 1975-134985, filed by Yoshiaki Hagiwara at Sony in 1975, show that Hagiwara invented Buried Photodiode (BPD) with the Pinned Surface Hole Accumulation, Pinned Photodiode (PPD) and Hole Accumulation Diode (HAD). It is also evident that Hagiwara invented Global Shutter Scheme of the three level clocking with MOS Capacitor Buffer Memory, clearly shown in JPA 1975-127646 and JPA 1975-127647. It is also evident that Hagiwara et al invented the Electrical Shutter Clocking Scheme by controlling punch-thru action of the in-pixel overflow drain (OFD) voltage as evidenced in JPA 1977-136885.

Color Reality

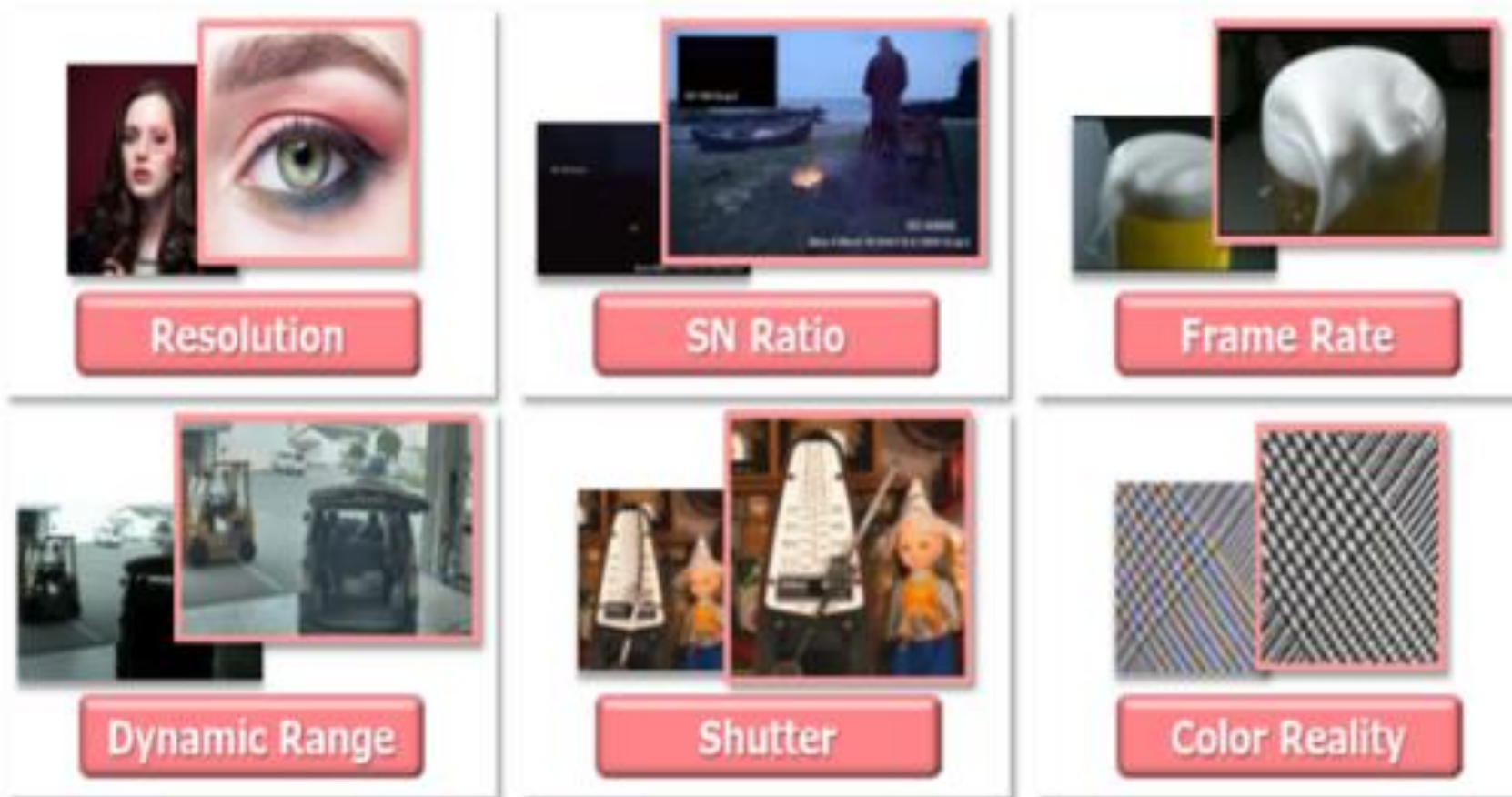

Hagiwara invented Pinned Photodiode (PPD).

Japanese Patent Applications, JPA1975-127646, JPA1975-127647 and JPA 1975-134985, filed by Yoshiaki Hagiwara at Sony in 1975, show that Hagiwara invented Buried Photodiode (BPD) with the Pinned Surface Hole Accumulation, Pinned Photodiode (PPD) and Hole Accumulation Diode (HAD). It is also evident that Hagiwara invented Global Shutter Scheme of the three level clocking with MOS Capacitor Buffer Memory, clearly shown in JPA 1975-127646 and JPA 1975-127647. It is also evident that Hagiwara et al invented the Electrical Shutter Clocking Scheme by controlling punch-thru action of the in-pixel overflow drain (OFD) voltage as evidenced in JPA 1977-136885.

(1) N+P junction Photodiode
in 1960s

The N+ surface is floating.

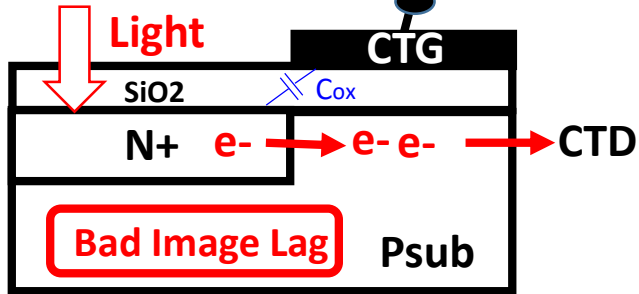

Oxide Capacitance Coupling also gives the Serious Image Lag Problem

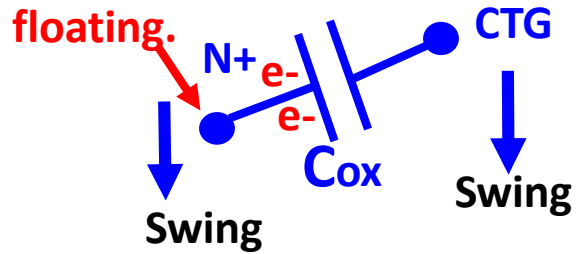

$$I_{ds} = K (V_s - V_{ch})^2$$

$$\text{As } (V_s - V_{ch}) \rightarrow 0$$

$$I_{ds} \rightarrow 0$$

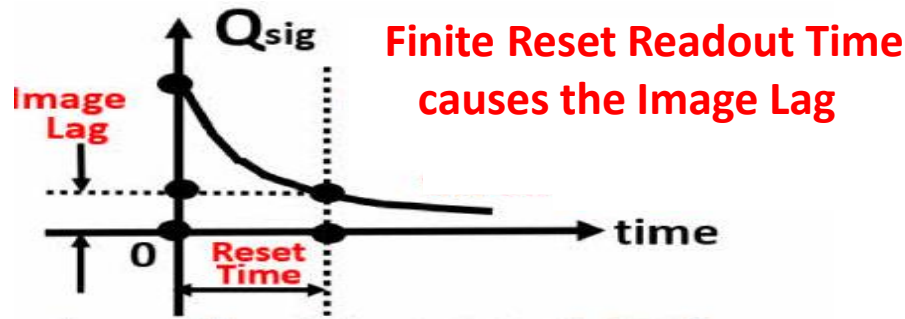
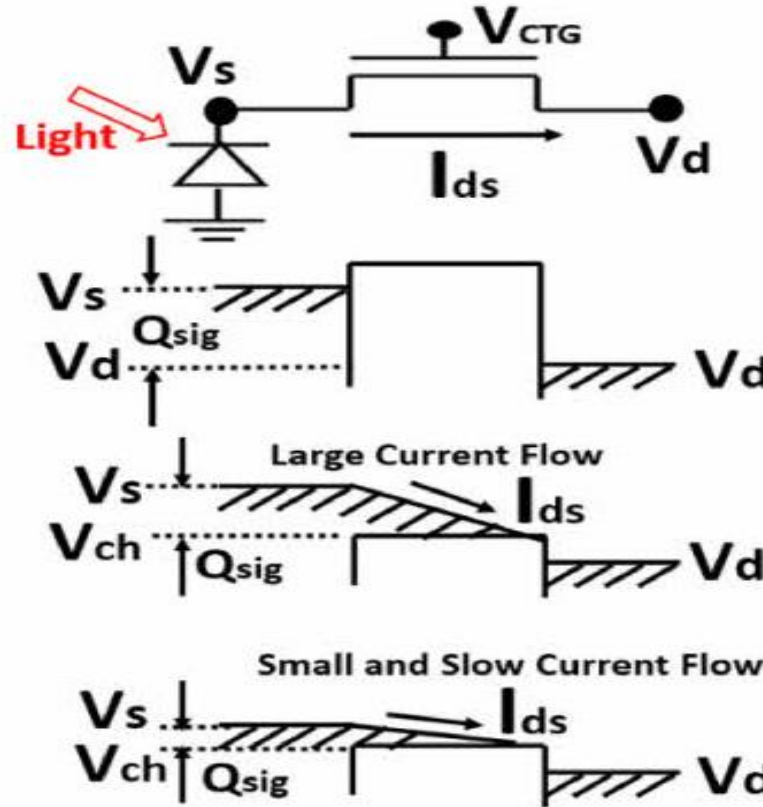

Hagiwara invented Pinned Photodiode (PPD).

Japanese Patent Applications, JPA1975-127646, JPA1975-127647 and JPA 1975-134985, filed by Yoshiaki Hagiwara at Sony in 1975, show that Hagiwara invented Buried Photodiode (BPD) with the Pinned Surface Hole Accumulation, Pinned Photodiode (PPD) and Hole Accumulation Diode (HAD). It is also evident that Hagiwara invented Global Shutter Scheme of the three level clocking with MOS Capacitor Buffer Memory, clearly shown in JPA 1975-127646 and JPA 1975-127647. It is also evident that Hagiwara et al invented the Electrical Shutter Clocking Scheme by controlling punch-thru action of the in-pixel overflow drain (OFD) voltage as evidenced in JPA 1977-136885.

(1) N+P junction Photodiode in 1960s

The N+ surface is floating.

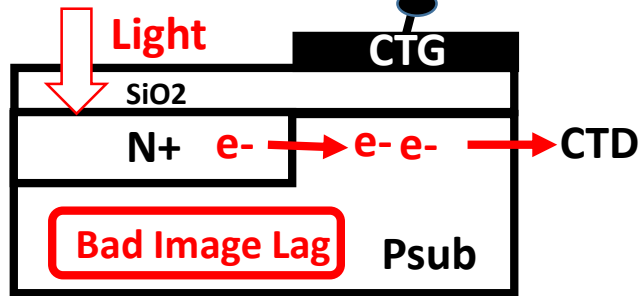

Oxide Capacitance Coupling also gives the Serious Image Lag Problem

More Problem

Poor Blue Light Sensitivity Problem

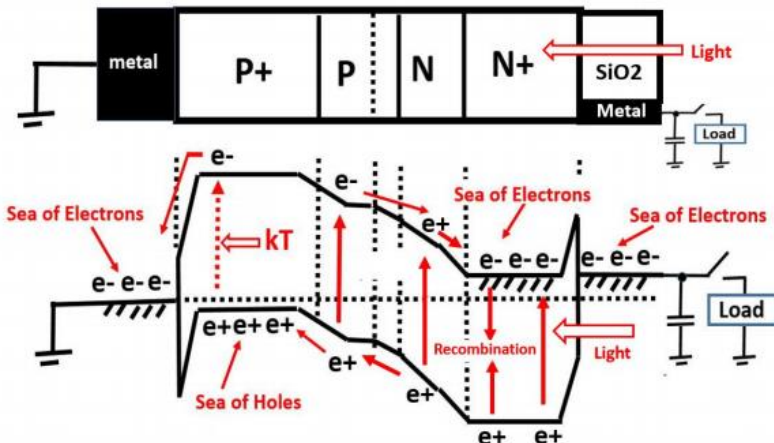

Single Junction N+P type Solar Cell also has a very poor short wave blue light sensitivity.

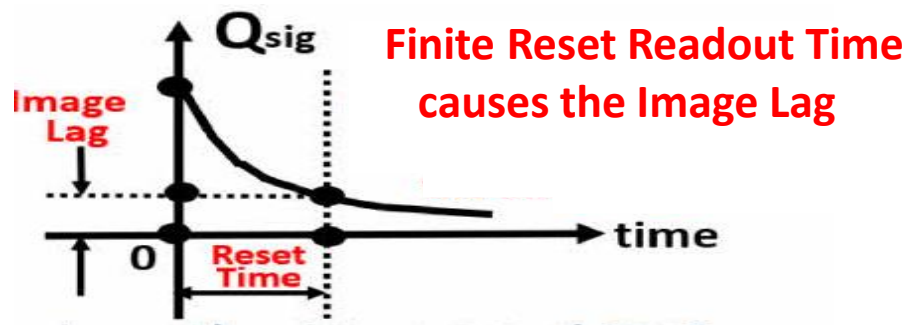
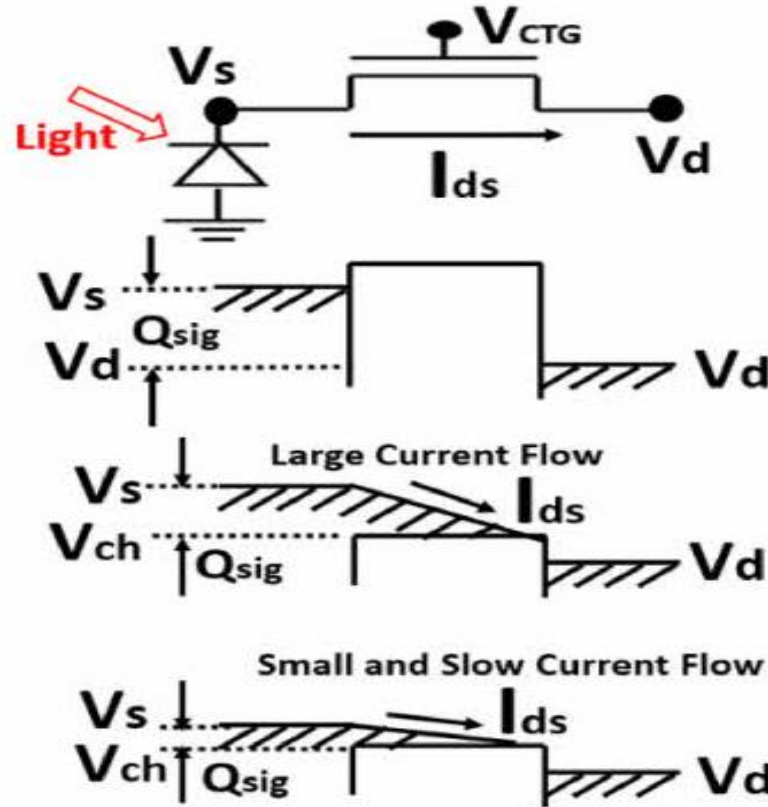

Hagiwara invented Pinned Photodiode (PPD).

Japanese Patent Applications, JPA1975-127646, JPA1975-127647 and JPA 1975-134985, filed by Yoshiaki Hagiwara at Sony in 1975, show that Hagiwara invented Buried Photodiode (BPD) with the Pinned Surface Hole Accumulation, Pinned Photodiode (PPD) and Hole Accumulation Diode (HAD). It is also evident that Hagiwara invented Global Shutter Scheme of the three level clocking with MOS Capacitor Buffer Memory, clearly shown in JPA 1975-127646 and JPA 1975-127647. It is also evident that Hagiwara et al invented the Electrical Shutter Clocking Scheme by controlling punch-thru action of the in-pixel overflow drain (OFD) voltage as evidenced in JPA 1977-136885.

(1) N+P junction Photodiode in 1960s

(2) Transparent Electrode CCD/MOS Photo Capacitor (1980)

The N+ surface is floating.

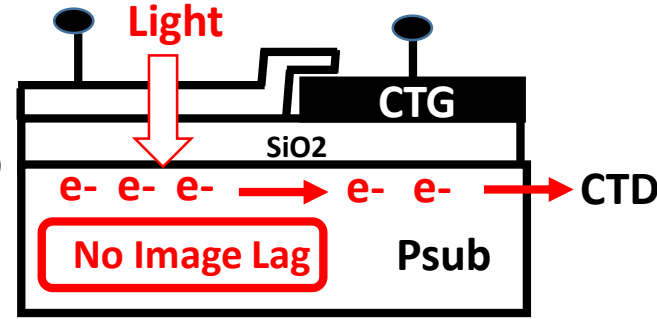
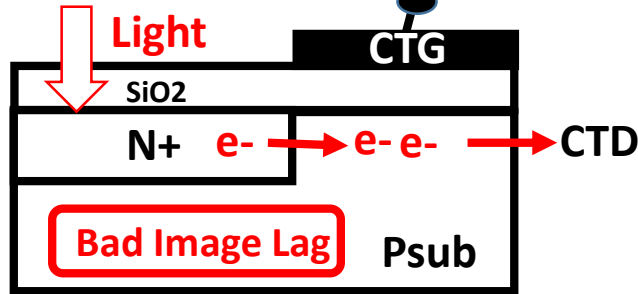

Oxide Capacitance Coupling also gives the Serious Image Lag Problem

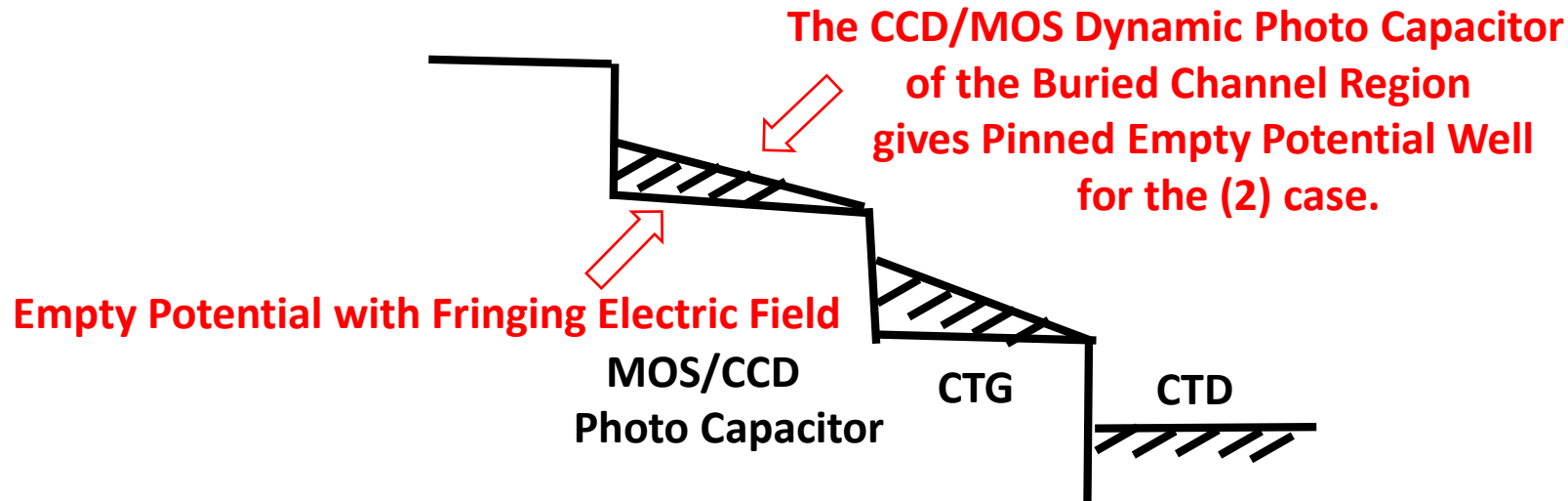

Hagiwara invented Pinned Photodiode (PPD).

Japanese Patent Applications, JPA1975-127646, JPA1975-127647 and JPA 1975-134985, filed by Yoshiaki Hagiwara at Sony in 1975, show that Hagiwara invented Buried Photodiode (BPD) with the Pinned Surface Hole Accumulation, Pinned Photodiode (PPD) and Hole Accumulation Diode (HAD). It is also evident that Hagiwara invented Global Shutter Scheme of the three level clocking with MOS Capacitor Buffer Memory, clearly shown in JPA 1975-127646 and JPA 1975-127647. It is also evident that Hagiwara et al invented the Electrical Shutter Clocking Scheme by controlling punch-thru action of the in-pixel overflow drain (OFD) voltage as evidenced in JPA 1977-136885.

(1) N+P junction Photodiode in 1960s

The N+ surface is floating.

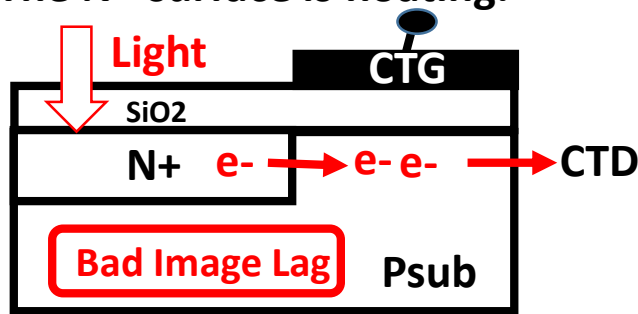

(2) Transparent Electrode CCD/MOS Photo Capacitor (1980)

Sony ICX-008 CCD chips (1980)

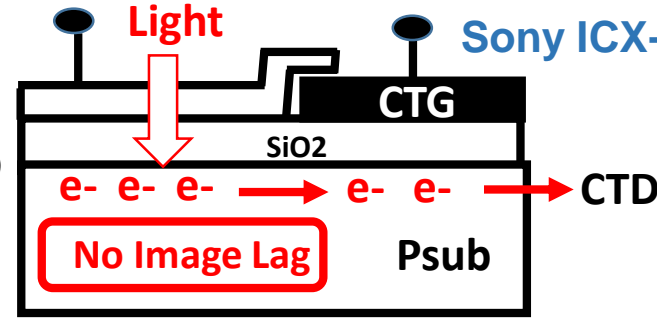

<ICX008>

Hagiwara invented Pinned Photodiode (PPD).

Japanese Patent Applications, JPA1975-127646, JPA1975-127647 and JPA 1975-134985, filed by Yoshiaki Hagiwara at Sony in 1975, show that Hagiwara invented Buried Photodiode (BPD) with the Pinned Surface Hole Accumulation, Pinned Photodiode (PPD) and Hole Accumulation Diode (HAD). It is also evident that Hagiwara invented Global Shutter Scheme of the three level clocking with MOS Capacitor Buffer Memory, clearly shown in JPA 1975-127646 and JPA 1975-127647. It is also evident that Hagiwara et al invented the Electrical Shutter Clocking Scheme by controlling punch-thru action of the in-pixel overflow drain (OFD) voltage as evidenced in JPA 1977-136885.

Oxide Capacitance Coupling and Serious Image Lag Problem



XC-1 1980
Two-Chip Color Video Camera

on ANA 747 Jumbo Jet



all solid state = robustness

- CCD/MOS Dynamic Photo Capacitor with no image lag for action pictures with Electric Shutter Function

**(3) P+NPNsub Junction
Photodiode**

Hole Accumulation Diode (HAD)

Complete Charge Transfer Mode
with No Image Lag Feature

Empty Potential with Fringing Electric Field

The Pinned Surface P+ potential gives
the Pinned Empty Potential Well
of the Buried Photodiode
for (3), (4) and (5) cases.

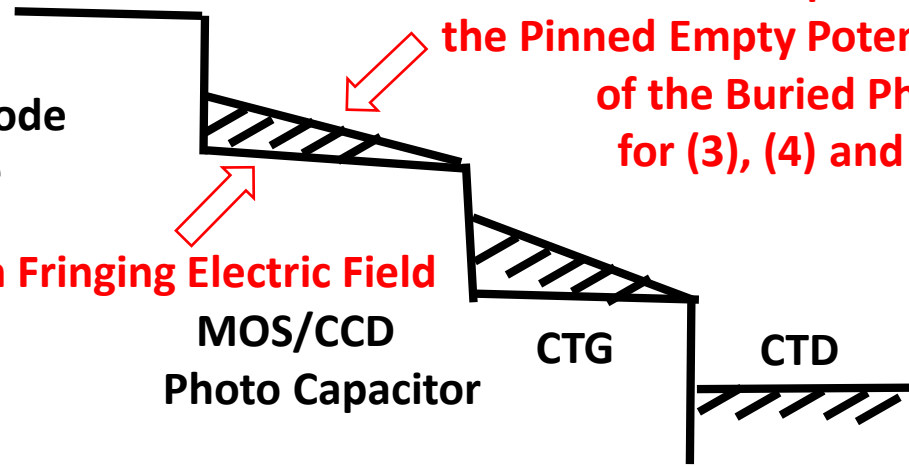

**(3) P+NPNsub Junction
Photodiode**

Hole Accumulation Diode (HAD)

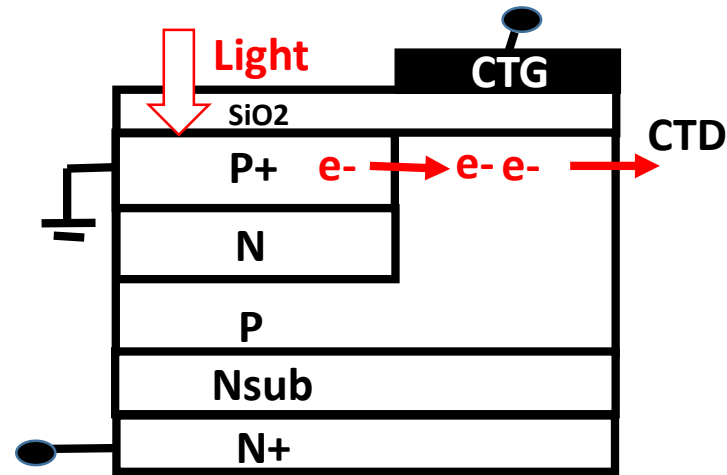

VOD JAP 1975-134985

Hagiwara invented Pinned Photodiode (PPD).

Japanese Patent Applications, JPA1975-127646, JPA1975-127647 and JPA 1975-134985, filed by Yoshiaki Hagiwara at Sony in 1975, show that Hagiwara invented Buried Photodiode (BPD) with the Pinned Surface Hole Accumulation, Pinned Photodiode (PPD) and Hole Accumulation Diode (HAD). It is also evident that Hagiwara invented Global Shutter Scheme of the three level clocking with MOS Capacitor Buffer Memory, clearly shown in JPA 1975-127646 and JPA 1975-127647. It is also evident that Hagiwara et al invented the Electrical Shutter Clocking Scheme by controlling punch-thru action of the in-pixel overflow drain (OFD) voltage as evidenced in JPA 1977-136885.

(4) P+PNP Junction Photodiode

**Global Shutter Buffer MOS
Memory**

**Complete Charge Transfer Mode
with No Image Lag Feature**

Empty Potential with Fringing Electric Field

**The Pinned Surface P+ potential gives
the Pinned Empty Potential Well
of the Buried Photodiode
for (3), (4) and (5) cases.**

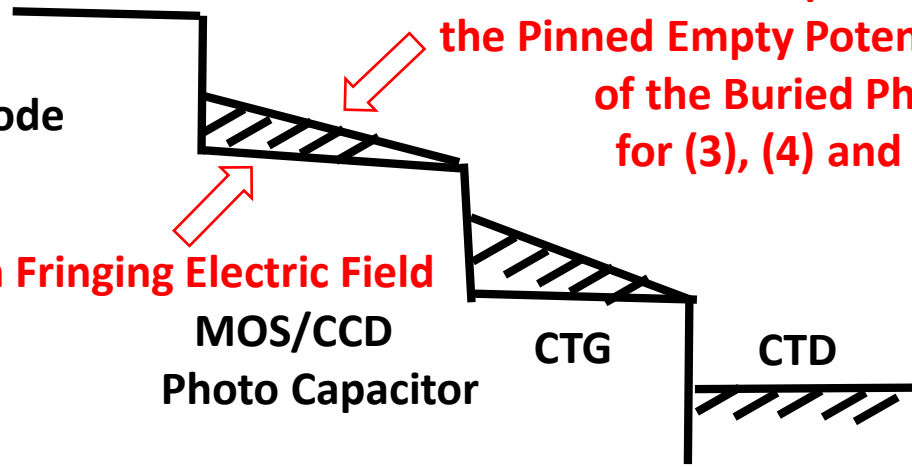

**MOS/CCD
Photo Capacitor**

CTG

CTD

**(3) P+NPNsub Junction
Photodiode**

**Hole Accumulation Diode (HAD)
Memory**

**(4) P+PNP Junction Photodiode
Global Shutter Buffer MOS
Memory**

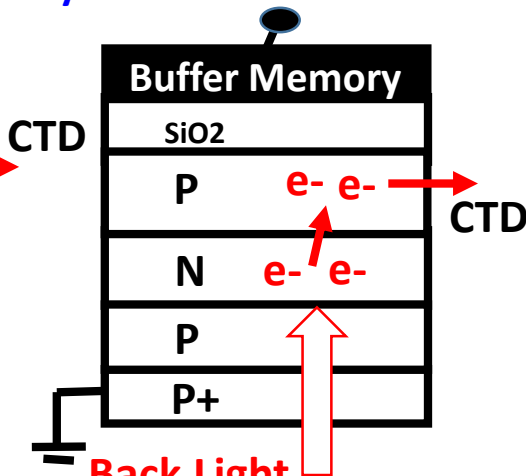
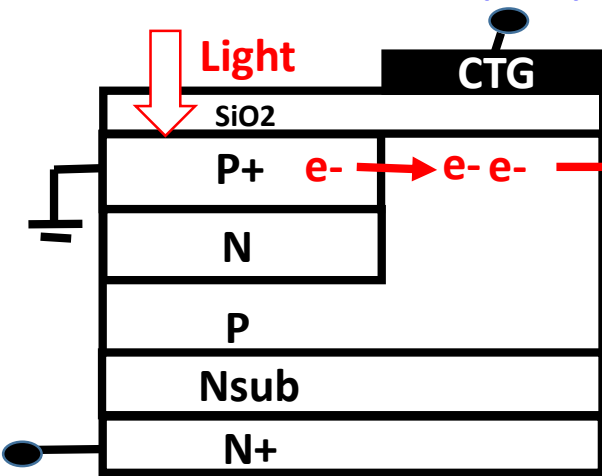

Hagiwara invented Pinned Photodiode (PPD).

Japanese Patent Applications, JPA1975-127646, JPA1975-127647 and JPA 1975-134985, filed by Yoshiaki Hagiwara at Sony in 1975, show that Hagiwara invented Buried Photodiode (BPD) with the Pinned Surface Hole Accumulation, Pinned Photodiode (PPD) and Hole Accumulation Diode (HAD). It is also evident that Hagiwara invented Global Shutter Scheme of the three level clocking with MOS Capacitor Buffer Memory, clearly shown in JPA 1975-127646 and JPA 1975-127647. It is also evident that Hagiwara et al invented the Electrical Shutter Clocking Scheme by controlling punch-thru action of the in-pixel overflow drain (OFD) voltage as evidenced in JPA 1977-136885.

VOD JAP 1975-134985

JAP 1975-127647

(5) P+PNPN Junction Photodiode
Global Shutter Buffer MOS
Memory

Complete Charge Transfer Mode
 with No Image Lag Feature

Empty Potential with Fringing Electric Field

The Pinned Surface P+ potential gives
 the Pinned Empty Potential Well
 of the Buried Photodiode
 for (3), (4) and (5) cases.

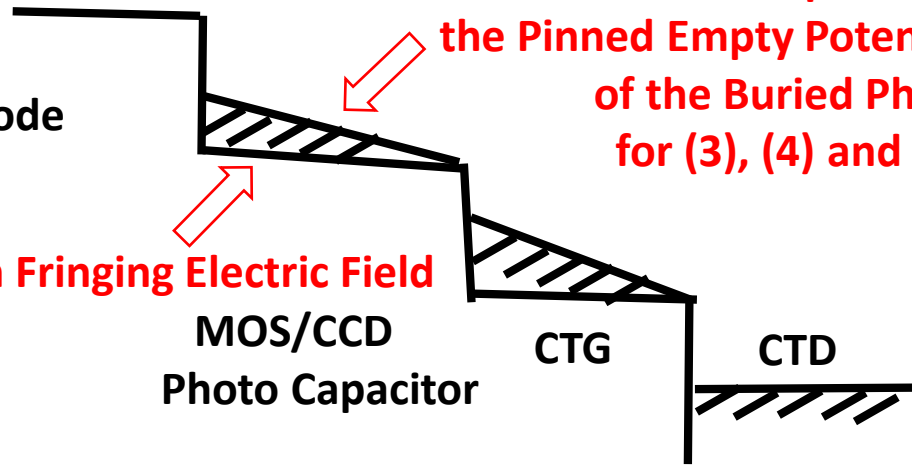

MOS/CCD
 Photo Capacitor

CTG

CTD

(3) P+NPNsub Junction
Photodiode

Hole Accumulation Diode (HAD)
 Memory

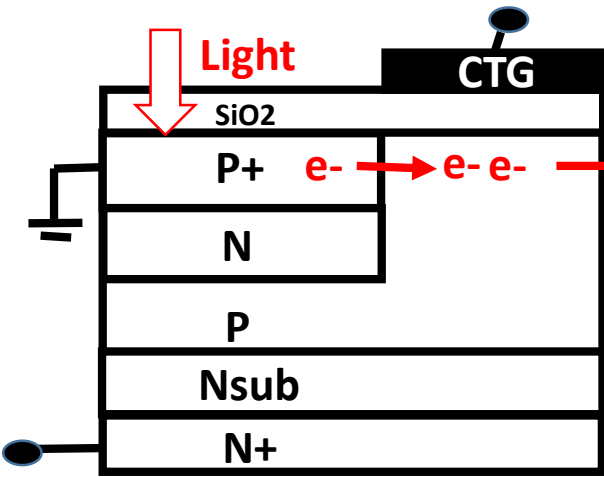

JAP 1975-134985

(4) P+PNP Junction Photodiode
Global Shutter Buffer MOS
Memory

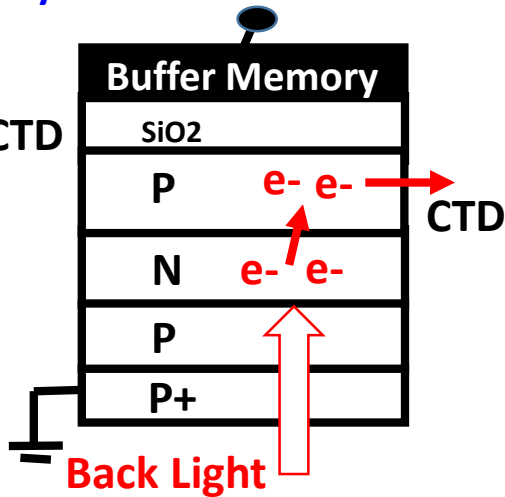

JAP 1975-127647

(5) P+PNPN Junction Photodiode
Global Shutter Buffer MOS
Memory

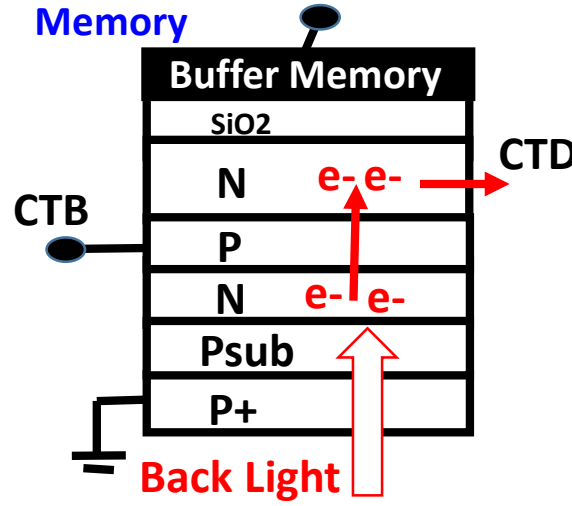

JAP 1975-127646

Hagiwara invented Pinned Photodiode (PPD).

Japanese Patent Applications, JPA1975-127646, JPA1975-127647 and JPA 1975-134985, filed by Yoshiaki Hagiwara at Sony in 1975, show that Hagiwara invented Buried Photodiode (BPD) with the Pinned Surface Hole Accumulation, Pinned Photodiode (PPD) and Hole Accumulation Diode (HAD). It is also evident that Hagiwara invented Global Shutter Scheme of the three level clocking with MOS Capacitor Buffer Memory, clearly shown in JPA 1975-127646 and JPA 1975-127647. It is also evident that Hagiwara et al invented the Electrical Shutter Clocking Scheme by controlling punch-thru action of the in-pixel overflow drain (OFD) voltage as evidenced in JPA 1977-136885.

(1) N+P junction Photodiode in 1960s

The N+ surface is floating.

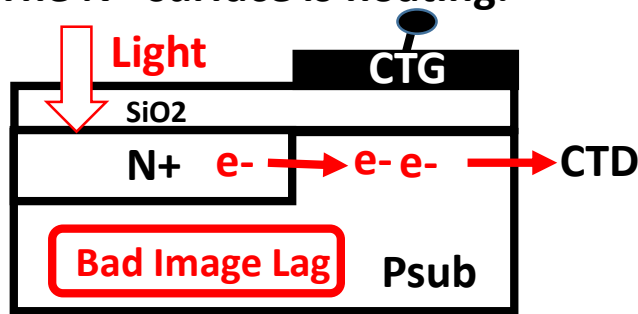

(2) Transparent Electrode CCD/MOS Photo Capacitor (1980)

Sony ICX-008 CCD chips (1980)

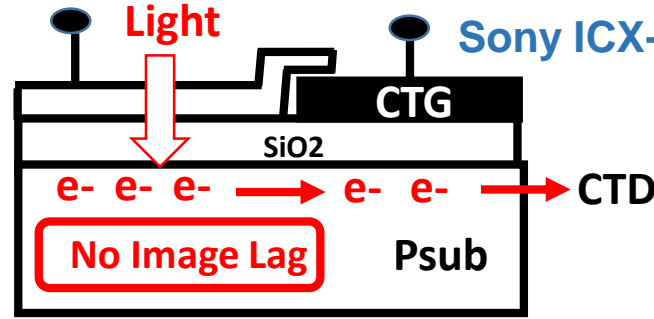

Hagiwara invented Pinned Photodiode (PPD).

Japanese Patent Applications, JPA1975-127646, JPA1975-127647 and JPA 1975-134985, filed by Yoshiaki Hagiwara at Sony in 1975, show that Hagiwara invented Buried Photodiode (BPD) with the Pinned Surface Hole Accumulation, Pinned Photodiode (PPD) and Hole Accumulation Diode (HAD). It is also evident that Hagiwara invented Global Shutter Scheme of the three level clocking with MOS Capacitor Buffer Memory, clearly shown in JPA 1975-127646 and JPA 1975-127647. It is also evident that Hagiwara et al invented the Electrical Shutter Clocking Scheme by controlling punch-thru action of the in-pixel overflow drain (OFD) voltage as evidenced in JPA 1977-136885.

Oxide Capacitance Coupling and Serious Image Lag Problem

(3) P+NPNsub Junction Photodiode

Hole Accumulation Diode (HAD) Memory

(4) P+PNP Junction Photodiode Global Shutter Buffer MOS

(5) P+PNPN Junction Photodiode Global Shutter Buffer MOS Memory

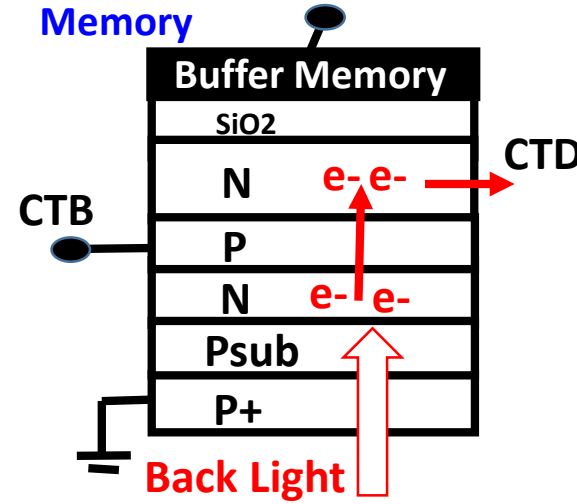
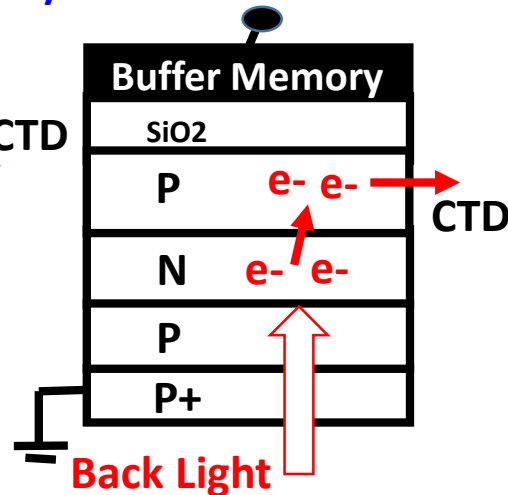
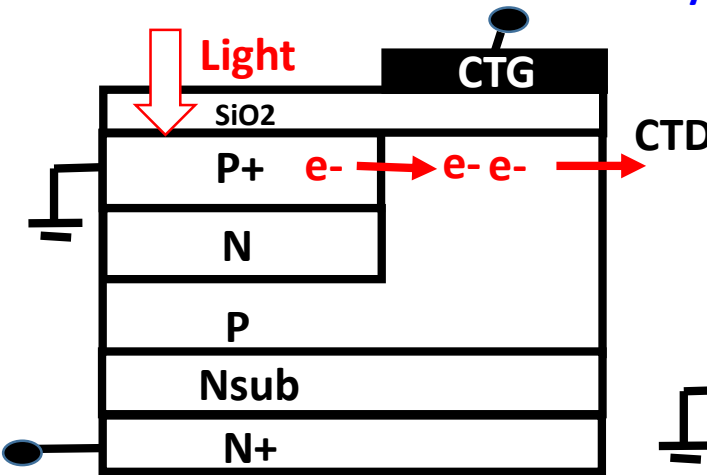

JAP 1975-134985

JAP 1975-127647

JAP 1975-127646

● P+NPNsub Pinned Photodiode (JAP 1975-134985)

with VOD function and No Image Lag by Hagiwara (1975)

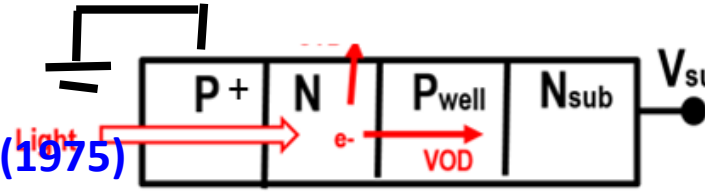

● NPNsub with VOD function (JAP 1978-1971)

by Yamada at Toshiba (1978)

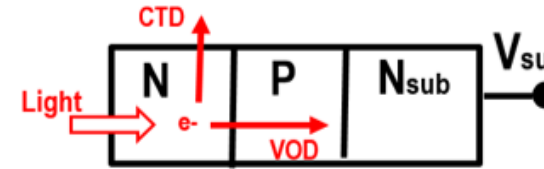

● PNPsub Buried Photodiode (JAP 1980-138026)

by Teranish at Toshiba (1978)

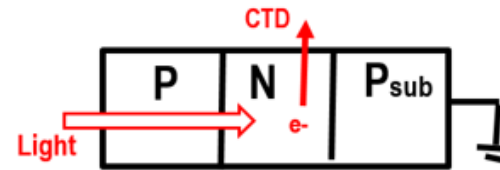

Comparison of Various Light Detecting Photo Sensor Structures

| feature \ type | Classical N+Psub Photodiode | Surface Channel CCD | Buried Channel CCD | Yamada 1978 NPNsub | Teranishi 1980 PNPsub | Hagiwara 1975 PNPsub |
|---------------------------|-----------------------------|---------------------|--------------------|--------------------|-----------------------|----------------------|
| Blue Light Sensitivity | △ | X | X | ○ | ○ | ○ |
| Low Image Lag | X | ○ | ○ | X | ○ | ○ |
| Surface Dark Current | ○ | X | X | X | ○ | ○ |
| Surface Trap Noise | ○ | X | ○ | X | ○ | ○ |
| Vertical OFD (VOD) | X | X | X | ○ | X | ○ |
| Electrical Shutter | X | X | X | X | X | ○ |

Hagiwara invented Pinned Photodiode (PPD).

Japanese Patent Applications, JPA1975-127646, JPA1975-127647 and JPA 1975-134985, filed by Yoshiaki Hagiwara at Sony in 1975, show that Hagiwara invented Buried Photodiode (BPD) with the Pinned Surface Hole Accumulation, Pinned Photodiode (PPD) and Hole Accumulation Diode (HAD). It is also evident that Hagiwara invented Global Shutter Scheme of the three level clocking with MOS Capacitor Buffer Memory, clearly shown in JPA 1975-127646 and JPA 1975-127647. It is also evident that Hagiwara et al invented the Electrical Shutter Clocking Scheme by controlling punch-thru action of the in-pixel overflow drain (OFD) voltage as evidenced in JPA 1977-136885.

The actual 1978 Sony HAD sensor has the P+PN+Psub Junction type Pinned Photodiode (PPD) sensor structure for the excellent short wave blue light sensitivity.

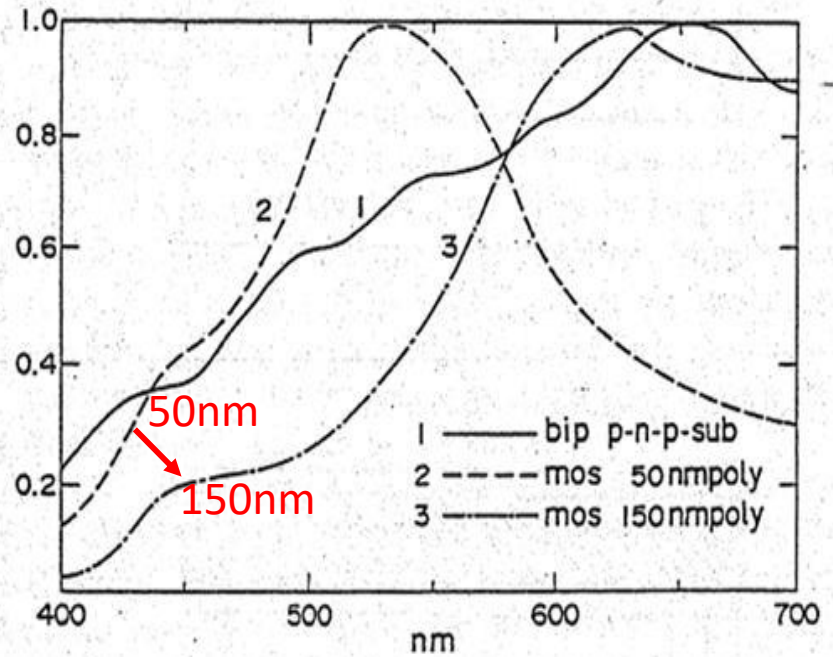
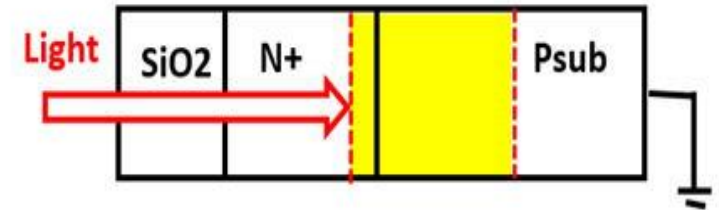

Fig. 7. Relative spectrum response. The relative response of the bipolar-type SiO₂-P₂-N₁-P₁-SUB structure is compared with poly-SiO₂-N₂-P(SUB) structures of the polysilicon thickness of 50 and 150 nm.

Yoshiaki Hagiwara, "High Density and High Quality Frame Transfer CCD Imager with Very Low Smear, Low Dark Current and Very High Blue Sensitivity", IEEE Transaction on Electron Devices, Vol 43, no. 12, December 1996
http://www.aiplab.com/P1996_Pinned_Photosidoe_used_in_Sony_1980_FT_CCD_Image_Sensor.pdf

(0) Original N+P junction type Photo Sensor with very poor short wave blue light sensitivity



(1) Bip PN Psub junction type Photo Sensor with excellent short wave blue light sensitivity

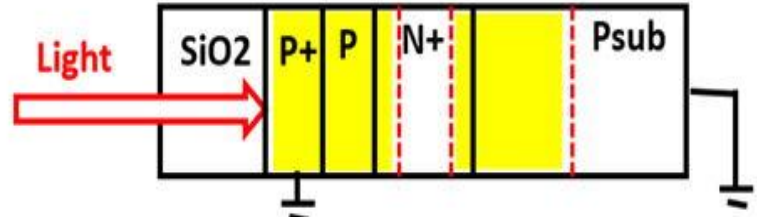

(2,3) MOS Capacitor type Photo Sensor with fairly good short wave blue light sensitivity

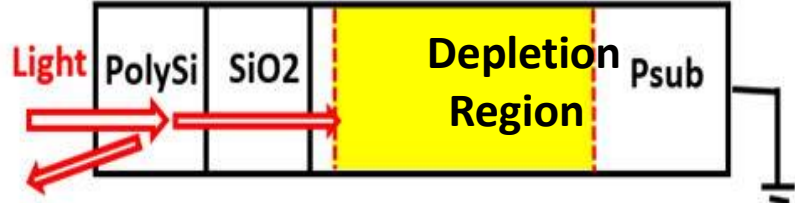

Hagiwara invented Pinned Photodiode (PPD).

Japanese Patent Applications, JPA1975-127646, JPA1975-127647 and JPA 1975-134985, filed by Yoshiaki Hagiwara at Sony in 1975, show that Hagiwara invented Buried Photodiode (BPD) with the Pinned Surface Hole Accumulation, Pinned Photodiode (PPD) and Hole Accumulation Diode (HAD). It is also evident that Hagiwara invented Global Shutter Scheme of the three level clocking with MOS Capacitor Buffer Memory, clearly shown in JPA 1975-127646 and JPA 1975-127647. It is also evident that Hagiwara et al invented the Electrical Shutter Clocking Scheme by controlling punch-thru action of the in-pixel overflow drain (OFD) voltage as evidenced in JPA 1977-136885.

**The N+PNP junction type Dynamic Photo Transistor Structure
Pinned Photodiode and Sony Hole Accumulation Diode (HAD)
with the vertical overflow drain (VOD) function
invented by Hagiwara at Sony in 1975**

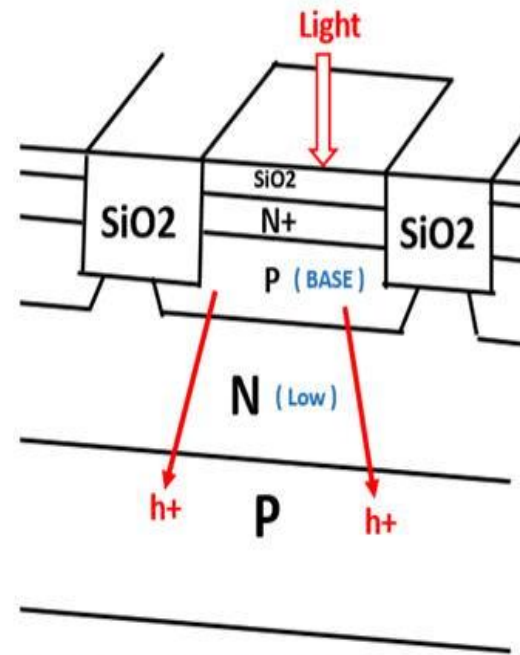
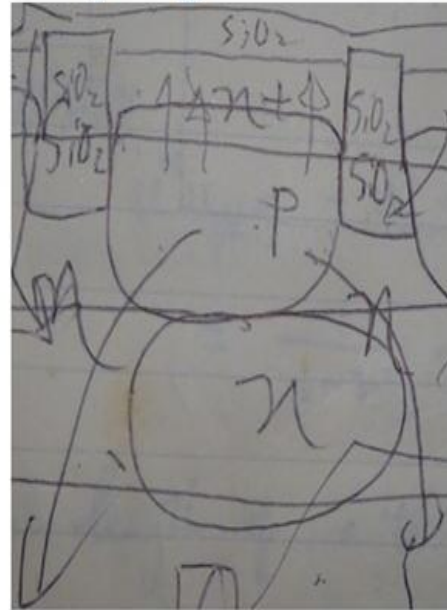
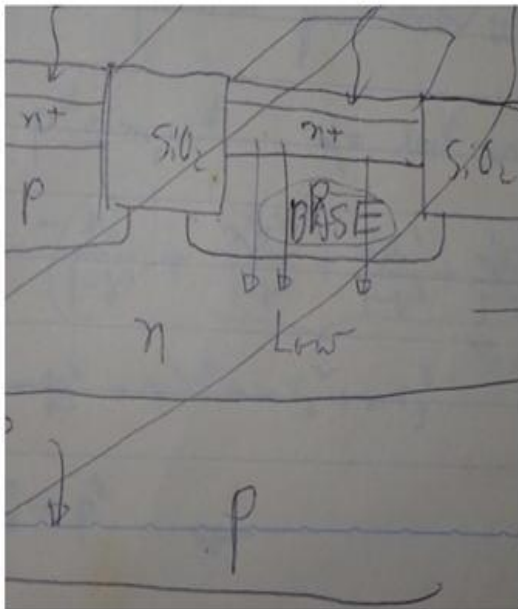

Hagiwara's Lab Note at Sony in February 1975

In 1975 at Sony, Yoshiaki Hagiwara filed three Japanese patents JPA1975-127646, JPA1975-127647 and JPA1975-134985 on the Pinned Surface Photodiode with the VOD function which is later called as Sony Hole Accumulation Diode (HAD).

Hagiwara did not file a patent on the SiO₂ device isolation but this lab note shows that Hagiwara had an idea of forming the Shallow Trench Isolation by the Local Oxidation Method, which was hinted by the LOCOS isolation in 1970s.

Hagiwara invented Pinned Photodiode (PPD).

Japanese Patent Applications, JPA1975-127646, JPA1975-127647 and JPA 1975-134985, filed by Yoshiaki Hagiwara at Sony in 1975, show that Hagiwara invented Buried Photodiode (BPD) with the Pinned Surface Hole Accumulation, Pinned Photodiode (PPD) and Hole Accumulation Diode (HAD). It is also evident that Hagiwara invented Global Shutter Scheme of the three level clocking with MOS Capacitor Buffer Memory, clearly shown in JPA 1975-127646 and JPA 1975-127647. It is also evident that Hagiwara et al invented the Electrical Shutter Clocking Scheme by controlling punch-thru action of the in-pixel overflow drain (OFD) voltage as evidenced in JPA 1977-136885.



Fig 6 of JPA 1975-134985 shows an example of Pinned Photodiode with the Jc Junction side used for the photo pair generation. Blue light cannot penetrate silicon crystal more than 0.1 μm .

Light(Jc) VOD(Je) type

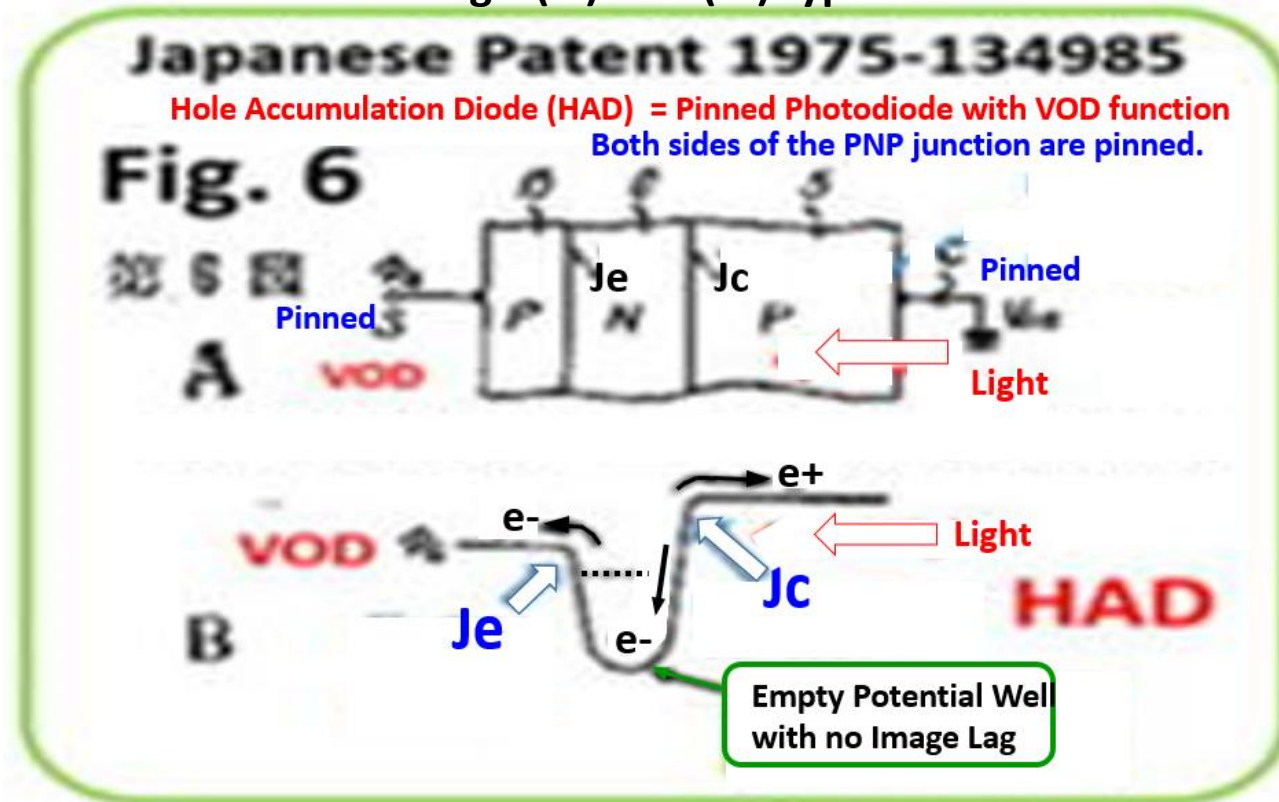

Hagiwara invented in 1975 the in-pixel vertical overflow drain (VOD) in the PNP double junction type dynamic photo transistor (Pinned Photodiode).

Hagiwara invented Pinned Photodiode (PPD).

Japanese Patent Applications, JPA1975-127646, JPA1975-127647 and JPA 1975-134985, filed by Yoshiaki Hagiwara at Sony in 1975, show that Hagiwara invented Buried Photodiode (BPD) with the Pinned Surface Hole Accumulation, Pinned Photodiode (PPD) and Hole Accumulation Diode (HAD). It is also evident that Hagiwara invented Global Shutter Scheme of the three level clocking with MOS Capacitor Buffer Memory, clearly shown in JPA 1975-127646 and JPA 1975-127647. It is also evident that Hagiwara et al invented the Electrical Shutter Clocking Scheme by controlling punch-thru action of the in-pixel overflow drain (OFD) voltage as evidenced in JPA 1977-136885.

Fig 6 of JPA 1975-134985 shows an example of Pinned Photodiode with Je Junction VOD Light(Jc) VOD(Je) type

Light(Je) VOD(Je) type

Fig 5 of JPA 1975-134985 shows an example of Pinned Photodiode with the Je Junction side used for the photo pair generation with the surface VOD metal contact.

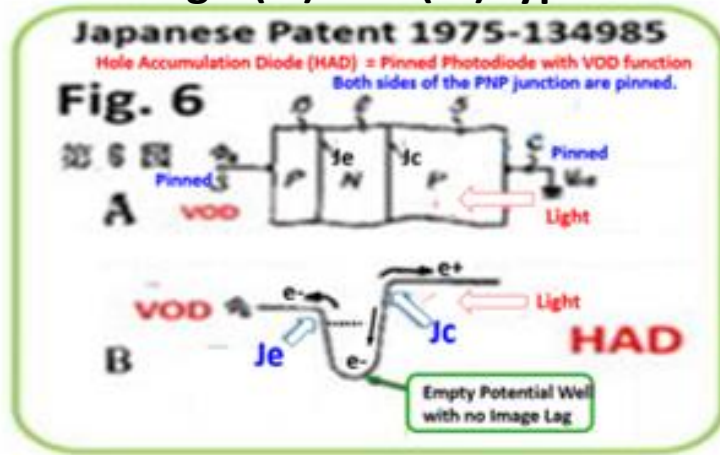

PPD needs P+ Channel Stops.

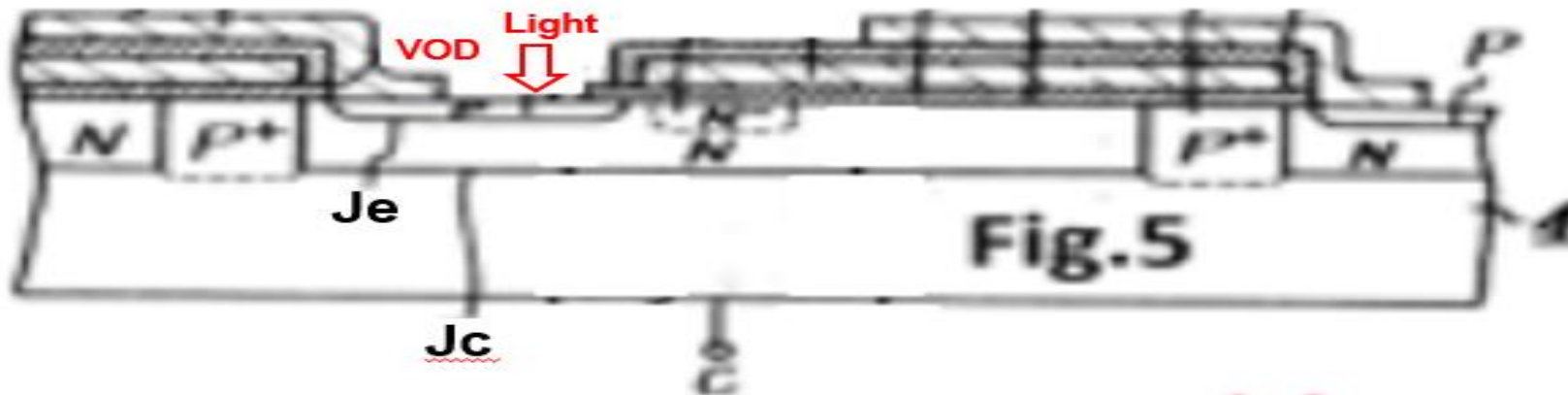

Hagiwara invented Pinned Photodiode (PPD).

Japanese Patent Applications, JPA1975-127646, JPA1975-127647 and JPA 1975-134985, filed by Yoshiaki Hagiwara at Sony in 1975, show that Hagiwara invented Buried Photodiode (BPD) with the Pinned Surface Hole Accumulation, Pinned Photodiode (PPD) and Hole Accumulation Diode (HAD). It is also evident that Hagiwara invented Global Shutter Scheme of the three level clocking with MOS Capacitor Buffer Memory, clearly shown in JPA 1975-127646 and JPA 1975-127647. It is also evident that Hagiwara et al invented the Electrical Shutter Clocking Scheme by controlling punch-thru action of the in-pixel overflow drain (OFD) voltage as evidenced in JPA 1977-136885.

VOD metal contact is optional. If the surface VOD is not needed, the VOD metal can be deleted and the surface P+ can be connected to the adjacent P+ channel stops.

PPD needs P+ Channel Stops.

Fig. 5 of the Japanese Patent Application JPA 1975-134985 shows the P+NP double junction type Pinned Photodiode with the VOD function

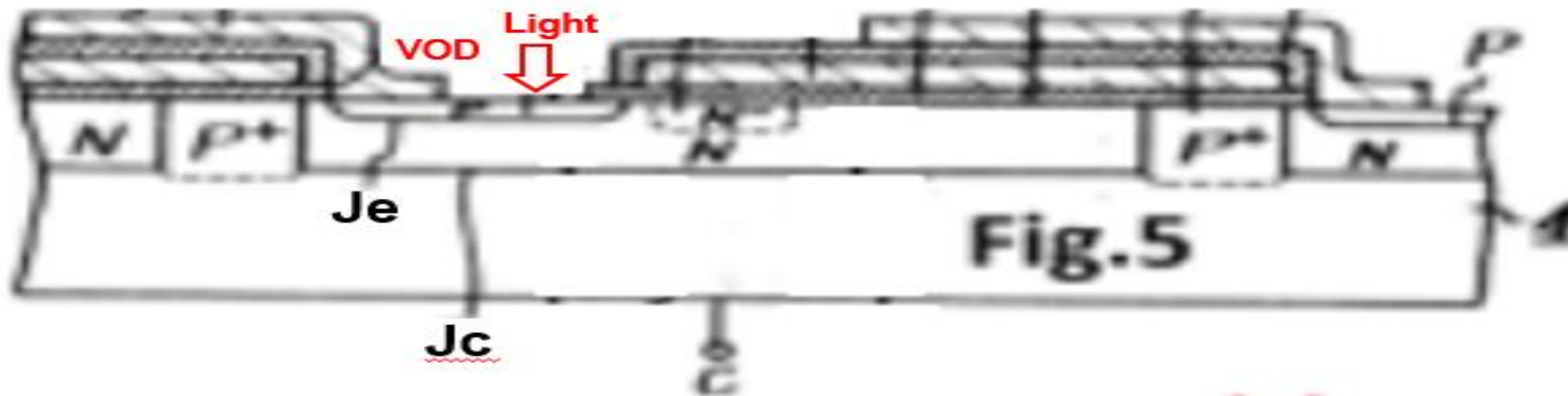
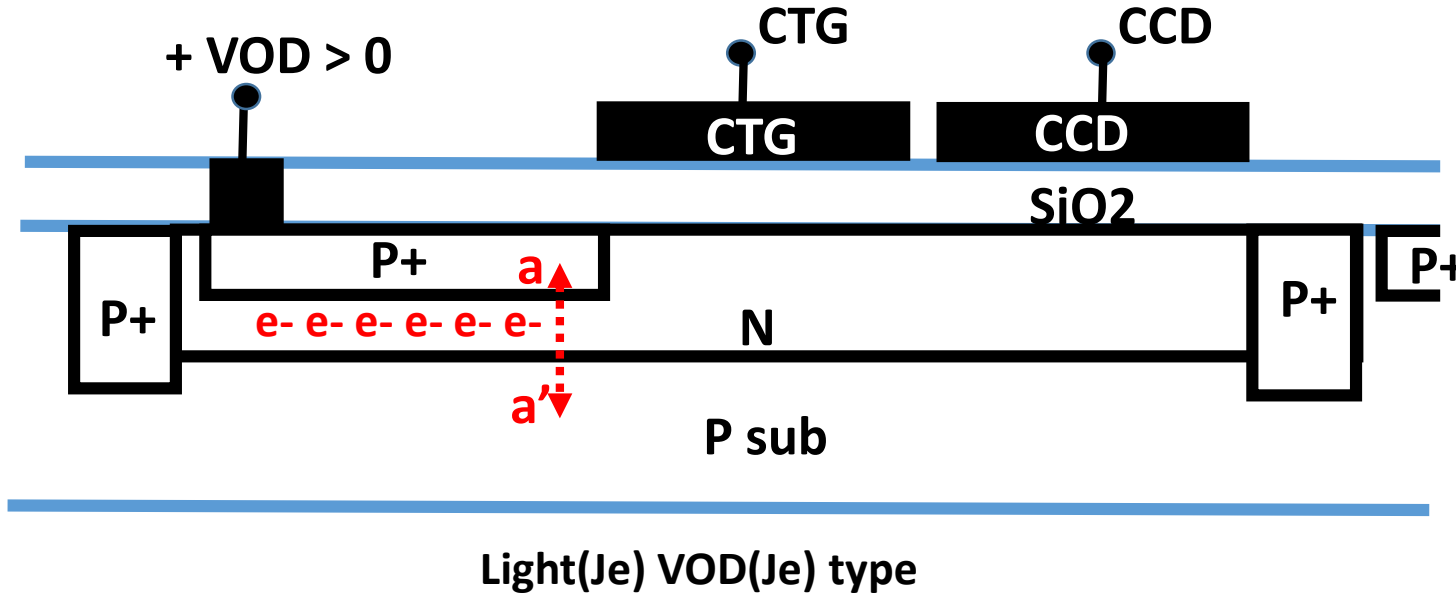

VOD metal contact is optional. If the surface VOD is not needed, the VOD metal contact can be deleted and the surface P+ can be connected to the adjacent P+ channel stops.

Hagiwara invented Pinned Photodiode (PPD).

Japanese Patent Applications, JPA1975-127646, JPA1975-127647 and JPA 1975-134985, filed by Yoshiaki Hagiwara at Sony in 1975, show that Hagiwara invented Buried Photodiode (BPD) with the Pinned Surface Hole Accumulation, Pinned Photodiode (PPD) and Hole Accumulation Diode (HAD). It is also evident that Hagiwara invented Global Shutter Scheme of the three level clocking with MOS Capacitor Buffer Memory, clearly shown in JPA 1975-127646 and JPA 1975-127647. It is also evident that Hagiwara et al invented the Electrical Shutter Clocking Scheme by controlling punch-thru action of the in-pixel overflow drain (OFD) voltage as evidenced in JPA 1977-136885.

PPD needs P+ Channel Stops.

Fig. 5 of the Japanese Patent Application JPA 1975-134985 shows the P+NP double junction type Pinned Photodiode with the VOD function

$+VOD > 0$

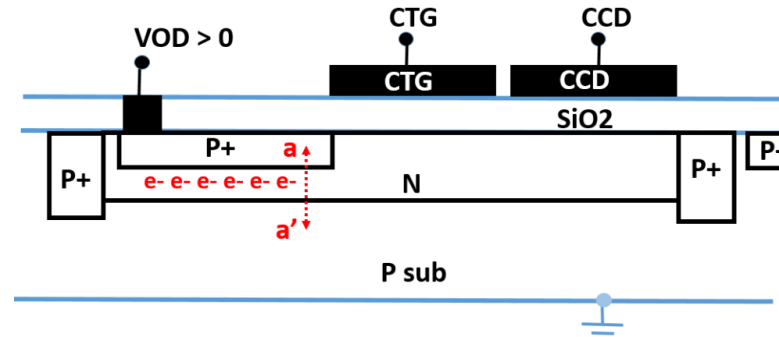
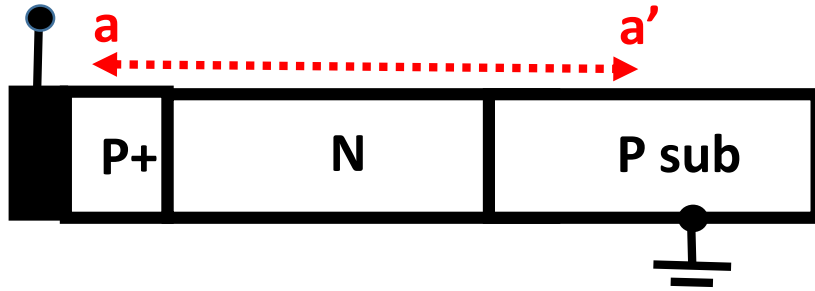

Hagiwara invented Pinned Photodiode (PPD).

Japanese Patent Applications, JPA1975-127646, JPA1975-127647 and JPA 1975-134985, filed by Yoshiaki Hagiwara at Sony in 1975, show that Hagiwara invented Buried Photodiode (BPD) with the Pinned Surface Hole Accumulation, Pinned Photodiode (PPD) and Hole Accumulation Diode (HAD). It is also evident that Hagiwara invented Global Shutter Scheme of the three level clocking with MOS Capacitor Buffer Memory, clearly shown in JPA 1975-127646 and JPA 1975-127647. It is also evident that Hagiwara et al invented the Electrical Shutter Clocking Scheme by controlling punch-thru action of the in-pixel overflow drain (OFD) voltage as evidenced in JPA 1977-136885.

VOD metal contact is optional. If the surface VOD is not needed, the VOD metal contact can be deleted and the surface P+ can be connected to the adjacent P+ channel stops.

PPD needs P+ Channel Stops.

Fig. 5 of the Japanese Patent Application JPA 1975-134985 shows the P+NP double junction type Pinned Photodiode with the VOD function

$+VOD > 0$

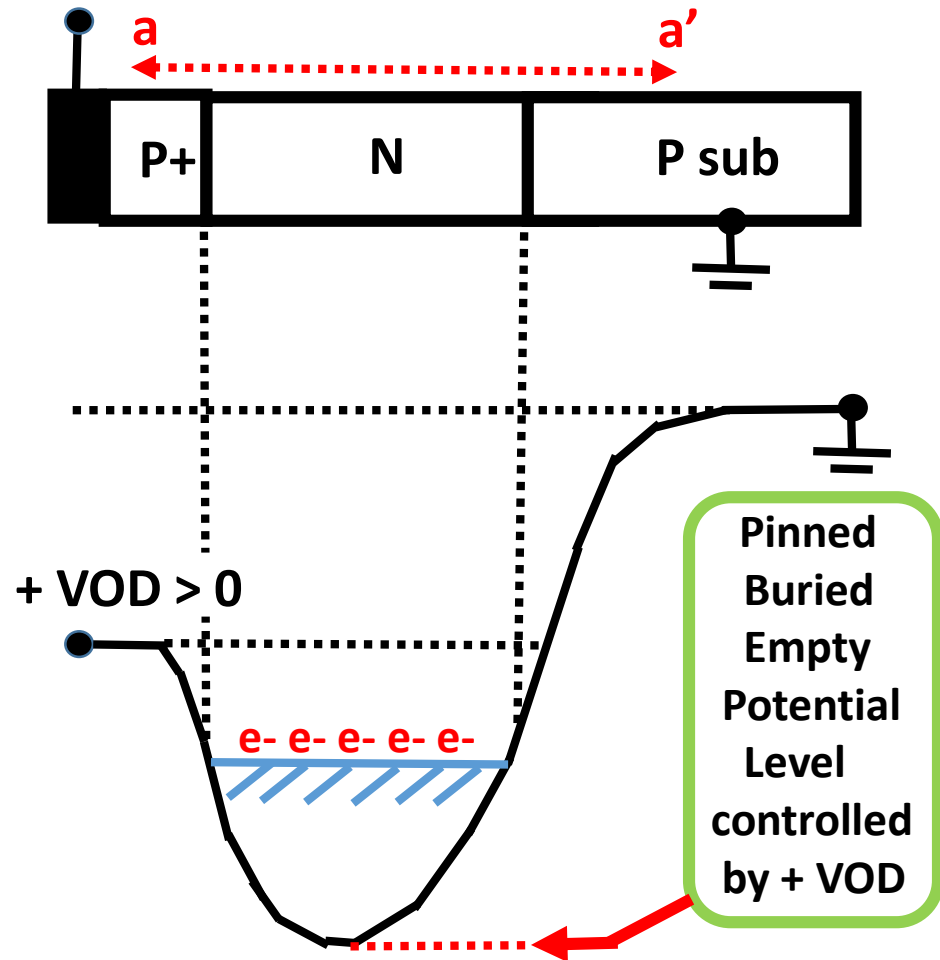

VOD metal contact is optional. If the surface VOD is not needed, the VOD metal contact can be deleted and the surface P+ can be connected to the adjacent P+ channel stops.

Hagiwara invented Pinned Photodiode (PPD).

Japanese Patent Applications, JPA1975-127646, JPA1975-127647 and JPA 1975-134985, filed by Yoshiaki Hagiwara at Sony in 1975, show that Hagiwara invented Buried Photodiode (BPD) with the Pinned Surface Hole Accumulation, Pinned Photodiode (PPD) and Hole Accumulation Diode (HAD). It is also evident that Hagiwara invented Global Shutter Scheme of the three level clocking with MOS Capacitor Buffer Memory, clearly shown in JPA 1975-127646 and JPA 1975-127647. It is also evident that Hagiwara et al invented the Electrical Shutter Clocking Scheme by controlling punch-thru action of the in-pixel overflow drain (OFD) voltage as evidenced in JPA 1977-136885.

PPD needs P+ Channel Stops.

Fig. 5 of the Japanese Patent Application JPA 1975-134985 shows the P+NP double junction type Pinned Photodiode with the VOD function

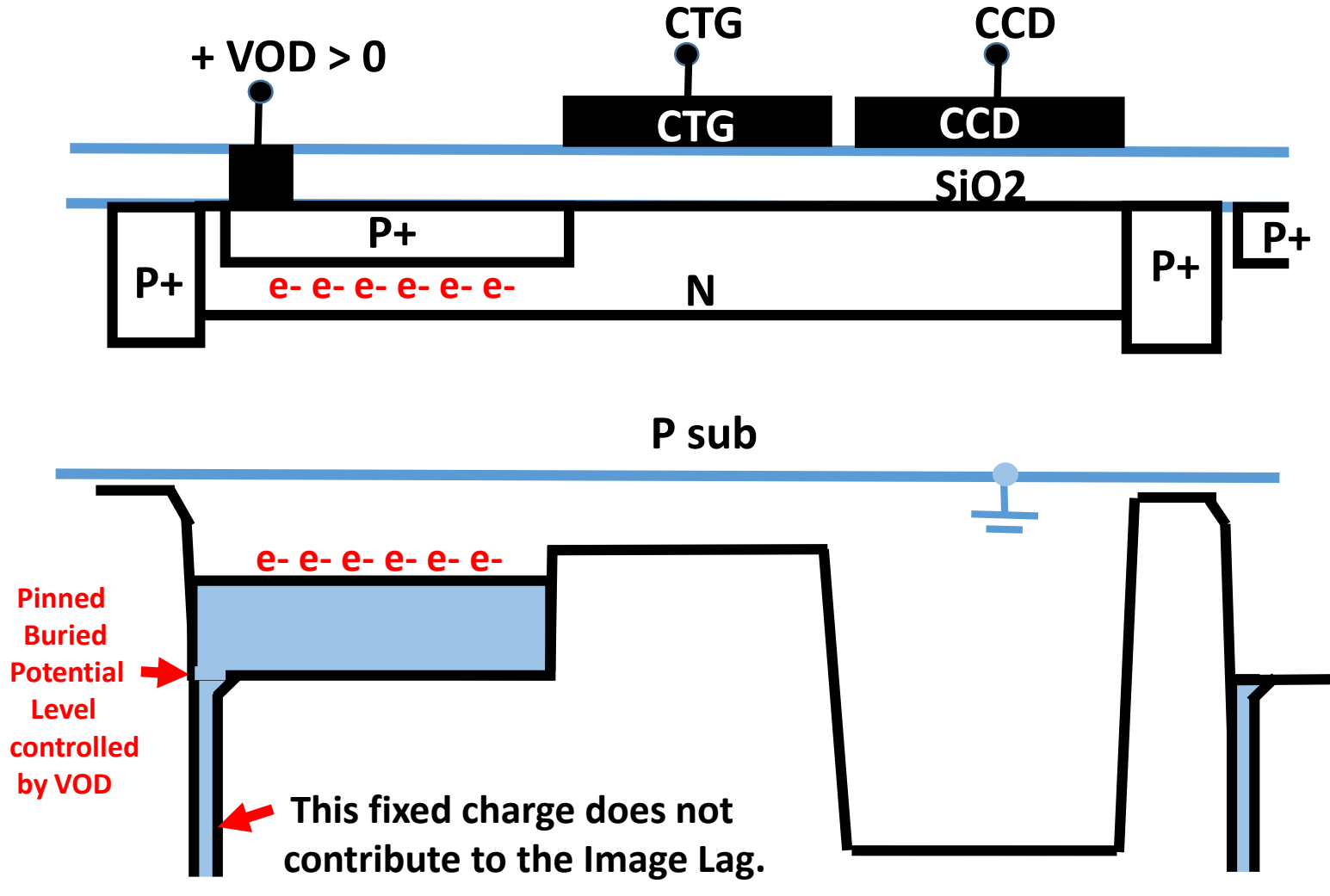

VOD metal contact is optional. If the surface VOD is not needed, the VOD metal contact can be deleted and the surface P^+ can be connected to the adjacent P^+ channel stops.

Hagiwara invented Pinned Photodiode (PPD).

Japanese Patent Applications, JPA1975-127646, JPA1975-127647 and JPA 1975-134985, filed by Yoshiaki Hagiwara at Sony in 1975, show that Hagiwara invented Buried Photodiode (BPD) with the Pinned Surface Hole Accumulation, Pinned Photodiode (PPD) and Hole Accumulation Diode (HAD). It is also evident that Hagiwara invented Global Shutter Scheme of the three level clocking with MOS Capacitor Buffer Memory, clearly shown in JPA 1975-127646 and JPA 1975-127647. It is also evident that Hagiwara et al invented the Electrical Shutter Clocking Scheme by controlling punch-thru action of the in-pixel overflow drain (OFD) voltage as evidenced in JPA 1977-136885.

PPD needs P+ Channel Stops.

Fig. 5 of the Japanese Patent Application JPA 1975-134985 shows the P+NP double junction type Pinned Photodiode with the VOD function

Hagiwara invented Pinned Photodiode (PPD).

Japanese Patent Applications, JPA1975-127646, JPA1975-127647 and JPA 1975-134985, filed by Yoshiaki Hagiwara at Sony in 1975, show that Hagiwara invented Buried Photodiode (BPD) with the Pinned Surface Hole Accumulation, Pinned Photodiode (PPD) and Hole Accumulation Diode (HAD). It is also evident that Hagiwara invented Global Shutter Scheme of the three level clocking with MOS Capacitor Buffer Memory, clearly shown in JPA 1975-127646 and JPA 1975-127647. It is also evident that Hagiwara et al invented the Electrical Shutter Clocking Scheme by controlling punch-thru action of the in-pixel overflow drain (OFD) voltage as evidenced in JPA 1977-136885.

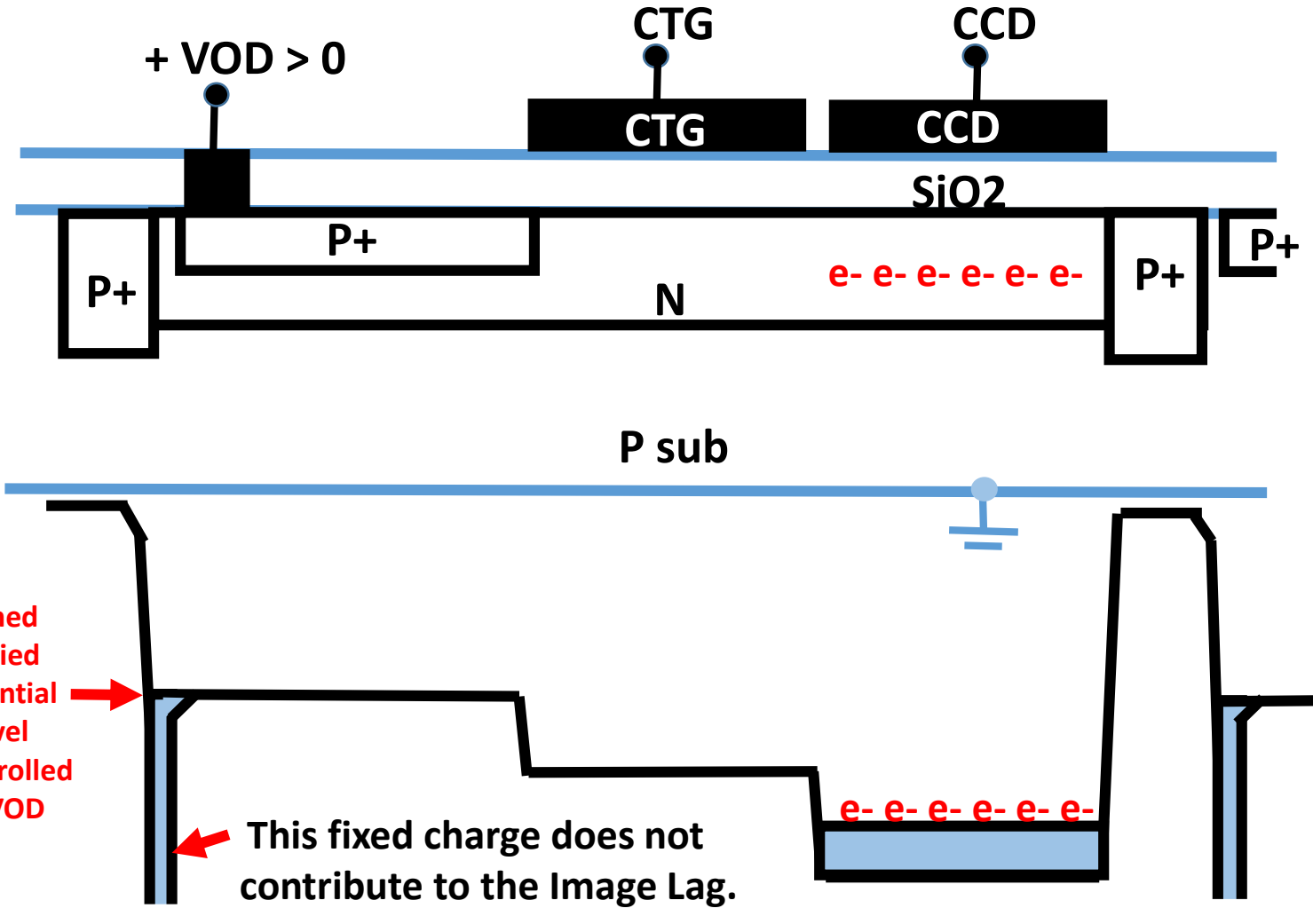

Pinned Buried Potential Level controlled by VOD

This fixed charge does not contribute to the Image Lag.

VOD metal contact is optional. If the surface VOD is not needed, the VOD metal contact can be deleted and the surface P+ can be connected to the adjacent P+ channel stops.

PPD needs P+ Channel Stops.

Fig. 5 of the Japanese Patent Application JPA 1975-134985 shows the P+NP double junction type Pinned Photodiode with the VOD function

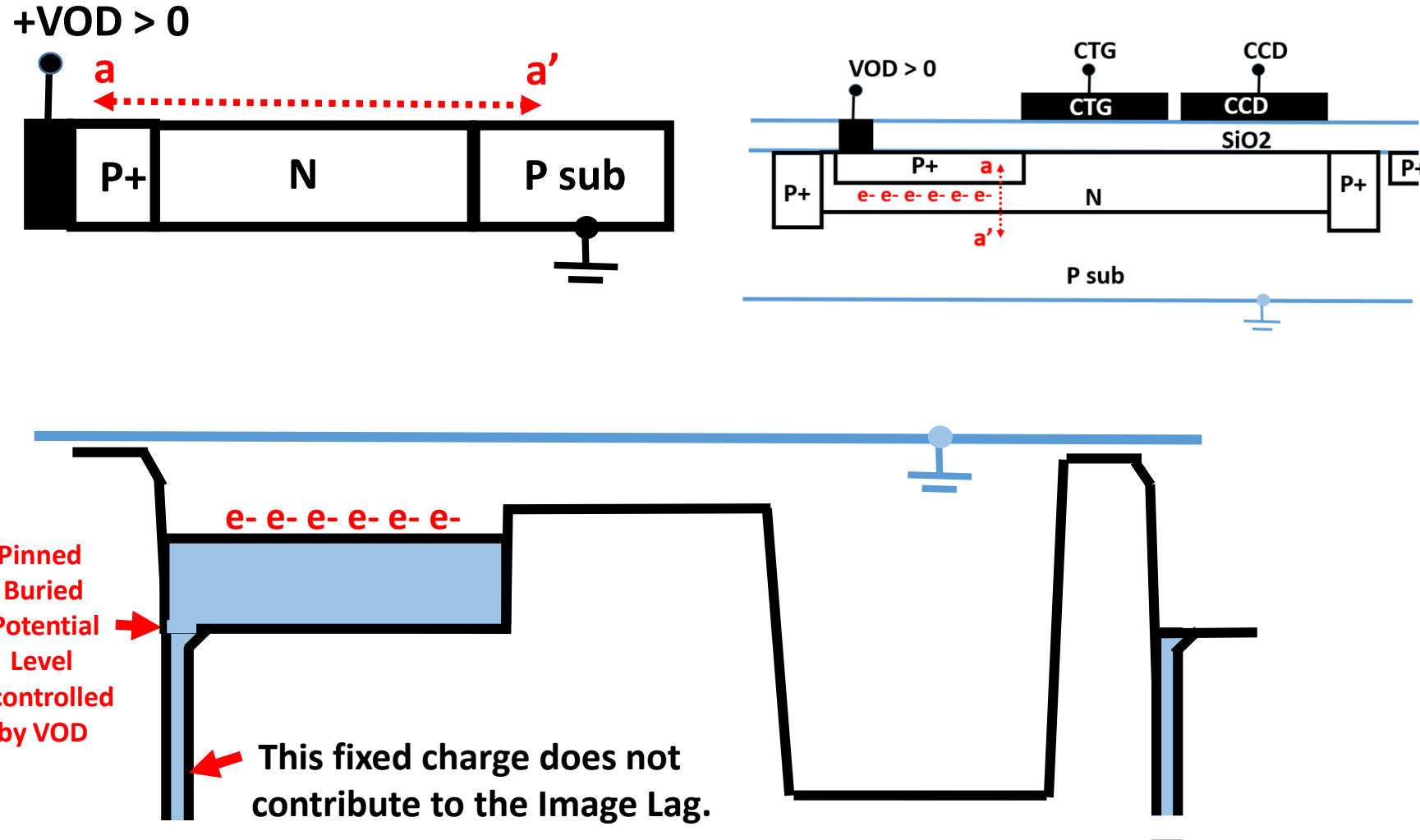

Hagiwara invented Pinned Photodiode (PPD).

Japanese Patent Applications, JPA1975-127646, JPA1975-127647 and JPA 1975-134985, filed by Yoshiaki Hagiwara at Sony in 1975, show that Hagiwara invented Buried Photodiode (BPD) with the Pinned Surface Hole Accumulation, Pinned Photodiode (PPD) and Hole Accumulation Diode (HAD). It is also evident that Hagiwara invented Global Shutter Scheme of the three level clocking with MOS Capacitor Buffer Memory, clearly shown in JPA 1975-127646 and JPA 1975-127647. It is also evident that Hagiwara et al invented the Electrical Shutter Clocking Scheme by controlling punch-thru action of the in-pixel overflow drain (OFD) voltage as evidenced in JPA 1977-136885.

VOD metal contact is optional. If the surface VOD is not needed, the VOD metal contact can be deleted and the surface P+ can be connected to the adjacent P+ channel stops.

PPD needs P+ Channel Stops.

Fig. 5 of the Japanese Patent Application JPA 1975-134985 shows the P+NP double junction type Pinned Photodiode with the VOD function

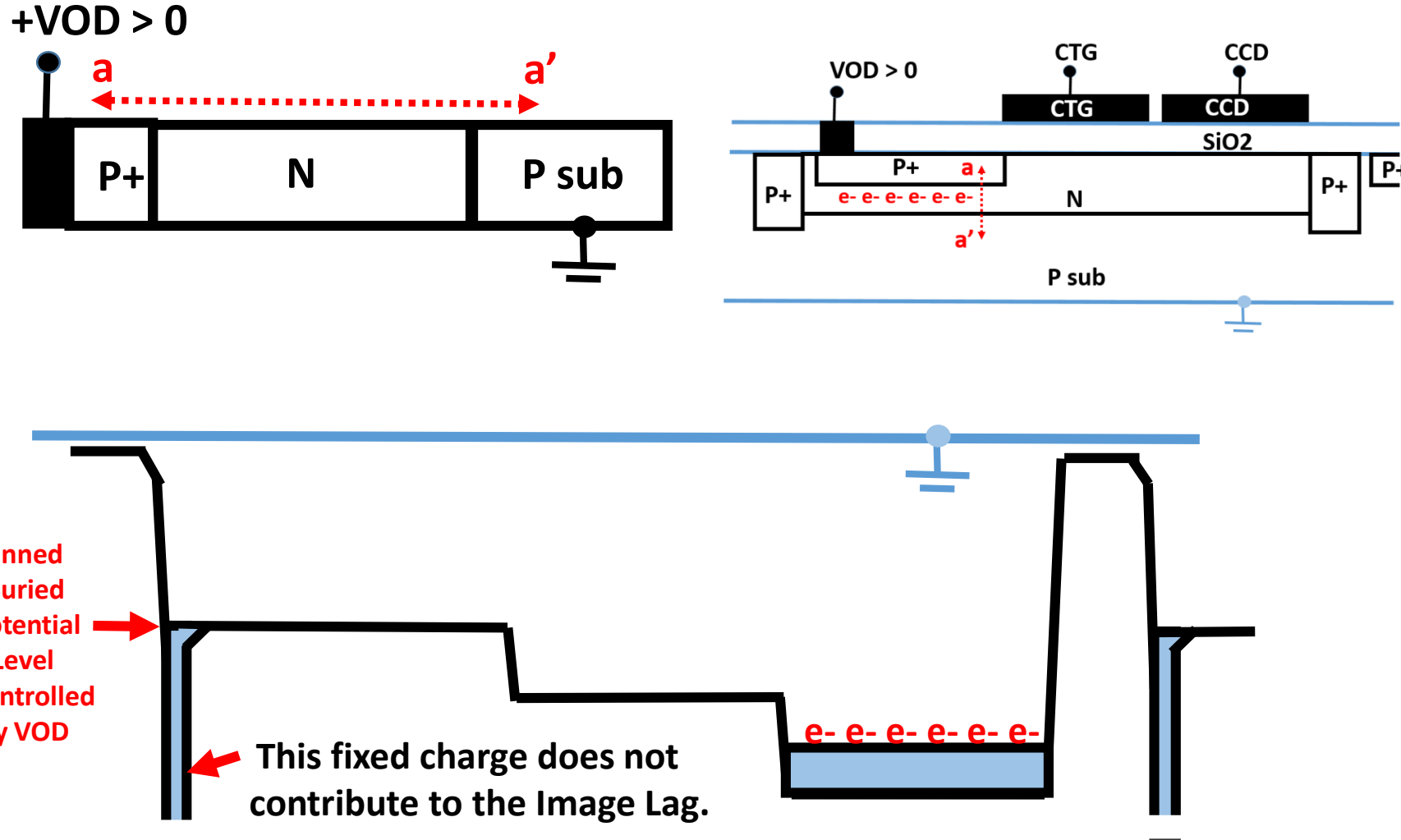

VOD metal contact is optional. If the surface VOD is not needed, the VOD metal contact can be deleted and the surface P+ can be connected to the adjacent P+ channel stops.

Hagiwara invented Pinned Photodiode (PPD).

Japanese Patent Applications, JPA1975-127646, JPA1975-127647 and JPA 1975-134985, filed by Yoshiaki Hagiwara at Sony in 1975, show that Hagiwara invented Buried Photodiode (BPD) with the Pinned Surface Hole Accumulation, Pinned Photodiode (PPD) and Hole Accumulation Diode (HAD). It is also evident that Hagiwara invented Global Shutter Scheme of the three level clocking with MOS Capacitor Buffer Memory, clearly shown in JPA 1975-127646 and JPA 1975-127647. It is also evident that Hagiwara et al invented the Electrical Shutter Clocking Scheme by controlling punch-thru action of the in-pixel overflow drain (OFD) voltage as evidenced in JPA 1977-136885.

PPD needs P+ Channel Stops.

Fig. 5 of the Japanese Patent Application JPA 1975-134985 shows the P+NP double junction type Pinned Photodiode with the VOD function

Hagiwara invented Pinned Photodiode (PPD).

Japanese Patent Applications, JPA1975-127646, JPA1975-127647 and JPA 1975-134985, filed by Yoshiaki Hagiwara at Sony in 1975, show that Hagiwara invented Buried Photodiode (BPD) with the Pinned Surface Hole Accumulation, Pinned Photodiode (PPD) and Hole Accumulation Diode (HAD). It is also evident that Hagiwara invented Global Shutter Scheme of the three level clocking with MOS Capacitor Buffer Memory, clearly shown in JPA 1975-127646 and JPA 1975-127647. It is also evident that Hagiwara et al invented the Electrical Shutter Clocking Scheme by controlling punch-thru action of the in-pixel overflow drain (OFD) voltage as evidenced in JPA 1977-136885.

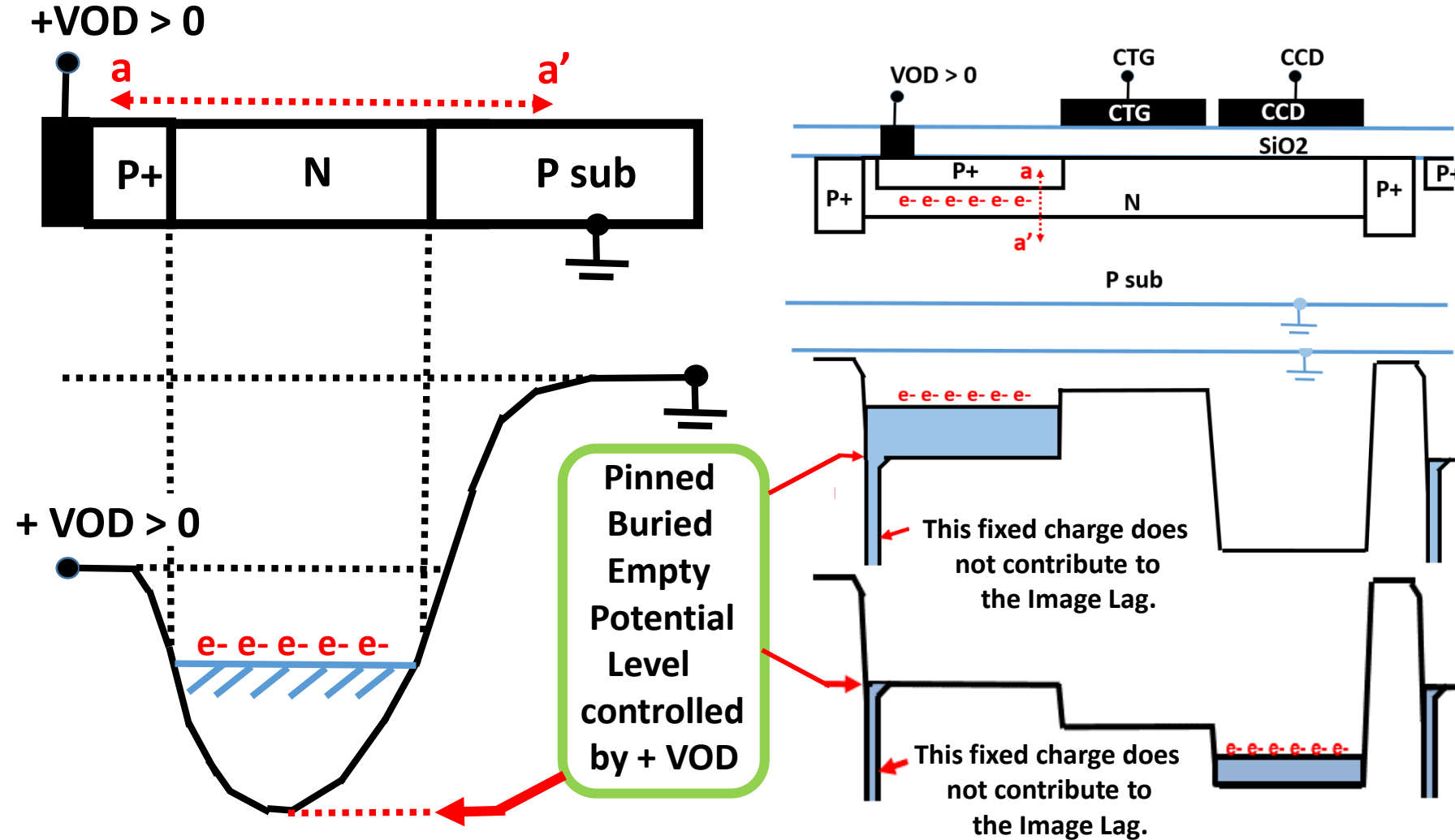

VOD metal contact is optional. If the surface VOD is not needed, the VOD metal contact can be deleted and the surface P+ can be connected to the adjacent P+ channel stops.

PPD needs P+ Channel Stops.

Fig. 5 of the Japanese Patent Application JPA 1975-134985 shows the P+NP double junction type Pinned Photodiode with the VOD function

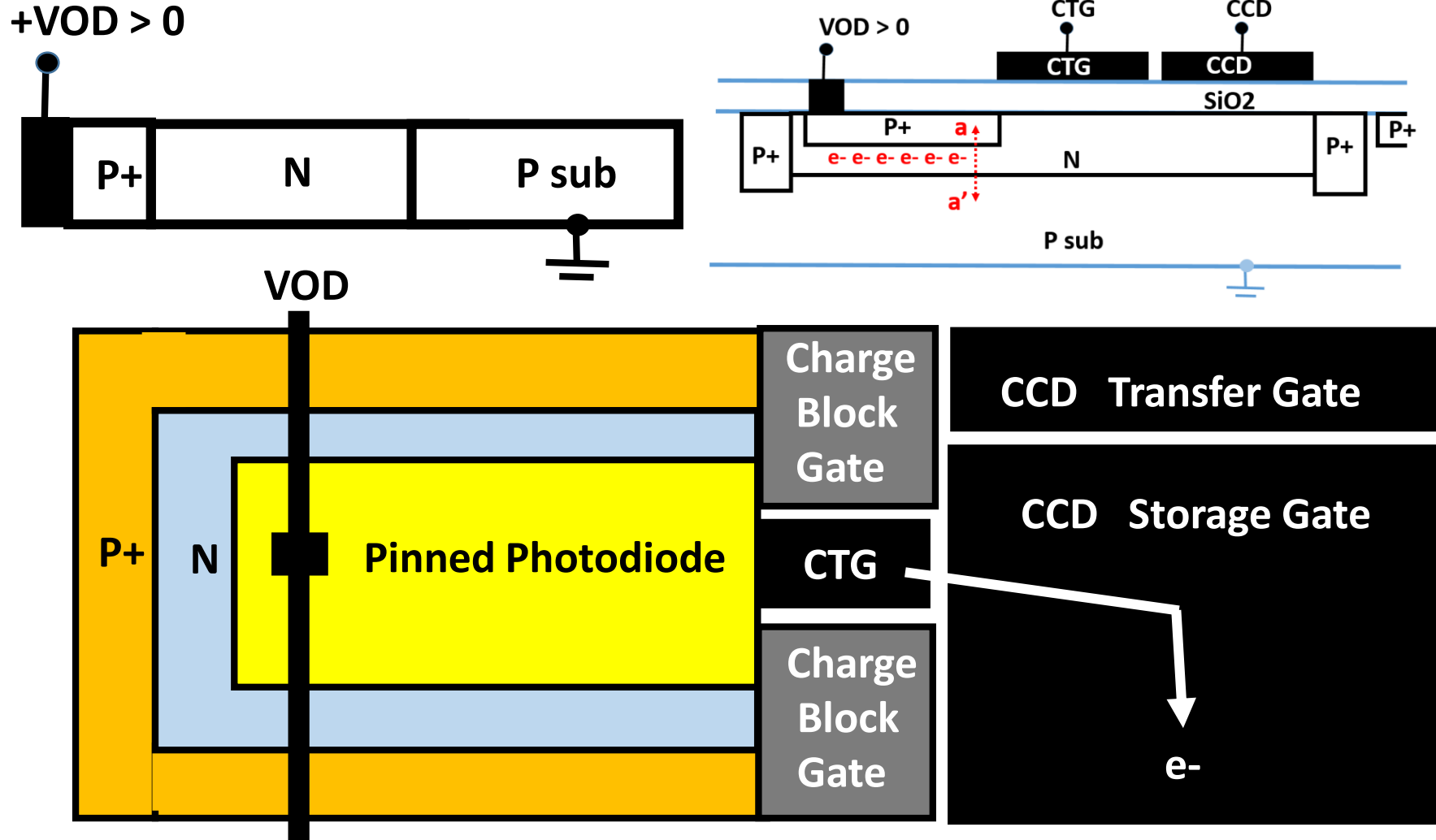

Hagiwara invented Pinned Photodiode (PPD).

Japanese Patent Applications, JPA1975-127646, JPA1975-127647 and JPA 1975-134985, filed by Yoshiaki Hagiwara at Sony in 1975, show that Hagiwara invented Buried Photodiode (BPD) with the Pinned Surface Hole Accumulation, Pinned Photodiode (PPD) and Hole Accumulation Diode (HAD). It is also evident that Hagiwara invented Global Shutter Scheme of the three level clocking with MOS Capacitor Buffer Memory, clearly shown in JPA 1975-127646 and JPA 1975-127647. It is also evident that Hagiwara et al invented the Electrical Shutter Clocking Scheme by controlling punch-thru action of the in-pixel overflow drain (OFD) voltage as evidenced in JPA 1977-136885.

VOD metal contact is optional. If the surface VOD is not needed, the VOD metal contact can be deleted and the surface P+ can be connected to the adjacent P+ channel stops.

Fig. 5 of the Japanese Patent Application JPA 1975-134985 is a hit to make a completely heavily doped P+ Channel Stops Less Pinned Photo Detecting Device (PPDD).

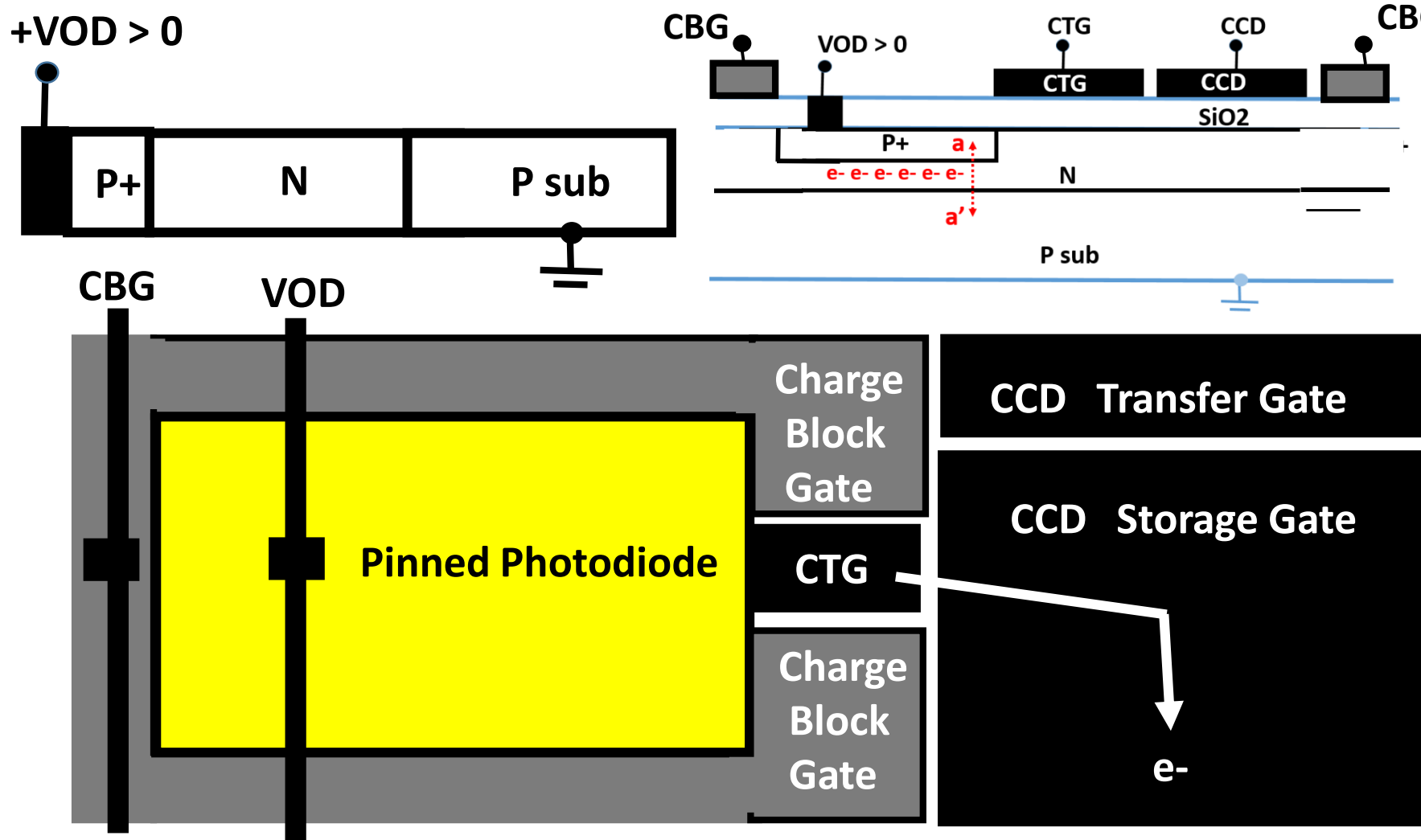

Hagiwara invented Pinned Photodiode (PPD).

Japanese Patent Applications, JPA1975-127646, JPA1975-127647 and JPA 1975-134985, filed by Yoshiaki Hagiwara at Sony in 1975, show that Hagiwara invented Buried Photodiode (BPD) with the Pinned Surface Hole Accumulation, Pinned Photodiode (PPD) and Hole Accumulation Diode (HAD). It is also evident that Hagiwara invented Global Shutter Scheme of the three level clocking with MOS Capacitor Buffer Memory, clearly shown in JPA 1975-127646 and JPA 1975-127647. It is also evident that Hagiwara et al invented the Electrical Shutter Clocking Scheme by controlling punch-thru action of the in-pixel overflow drain (OFD) voltage as evidenced in JPA 1977-136885.

VOD metal contact is optional. If the surface VOD is not needed, the VOD metal contact can be deleted and the surface P+ can be connected to the adjacent P+ channel stops.

SONY HAD (Pinned Photodiode) Publications at the International Solid State Device Conference in 1978 and the Tokyo & New York SONY Press Conference in 1980

The original Pinned Photodiode (PPD) structure was invented by Hagiwara at Sony in 1975. The first one-chip color video camera with a FT CCD image sensor with P+NP junction type Pinned Photodiode (PPD) was reported by Sony in 1980 at Tokyo Press Conference by Iwama Kazuo of Sony president, and at New York Press conference by Morita Akio of Sony chairman.

Sony original 570H x 498 V one-chip FT CCD Image Sensor with Pinned Photodiode, July 1980

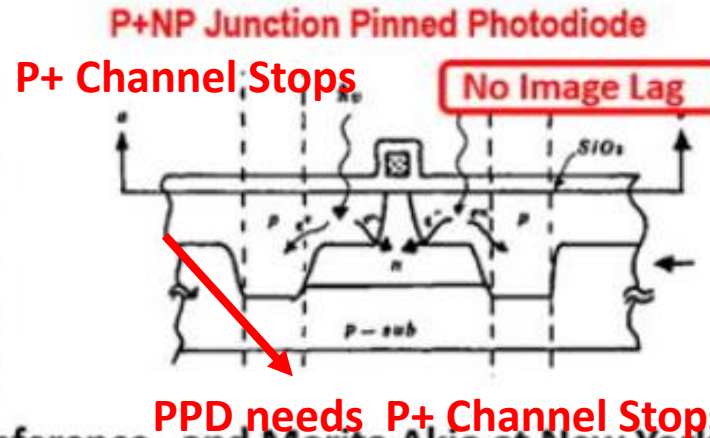
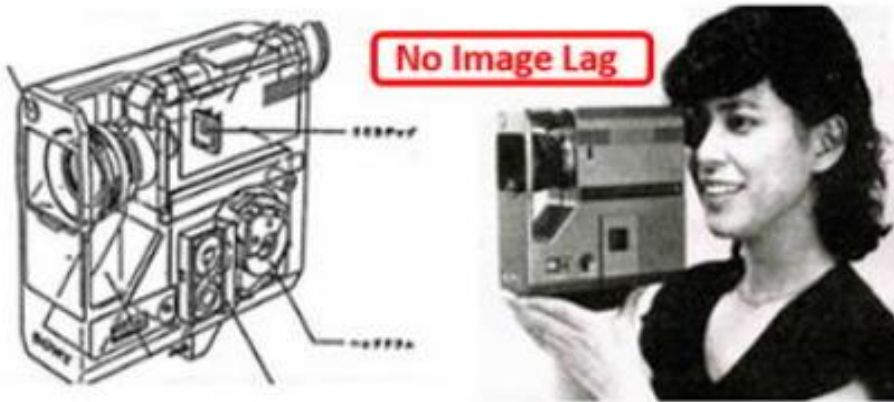

PPD needs P+ Channel Stops.

On July 1980, Iwama Kazuo at Sony Tokyo Press Conference and Morita Akio at New York Press Conference announced the one chip CCD video camera with the 8 mm VTR in one box.

See the Original 1978 Publication of the Pinned Photodiode Sensor

Y. Daimon-Hagiwara, M. Abe, and C. Okada, "A 380Hx488V CCD imager with narrow channel transfer gates," Proceedings of the 10th Conference on Solid State Devices, Tokyo, 1978; Japanese Journal of Applied Physics, vol. 18, supplement 18-1, pp. 335-340, 1979

High quality picture of SONY CMOS Imager is also based on SONY HAD (Pinned Photodiode).

Hagiwara invented Pinned Photodiode (PPD).

Japanese Patent Applications, JPA1975-127646, JPA1975-127647 and JPA 1975-134985, filed by Yoshiaki Hagiwara at Sony in 1975, show that Hagiwara invented Buried Photodiode (BPD) with the Pinned Surface Hole Accumulation, Pinned Photodiode (PPD) and Hole Accumulation Diode (HAD). It is also evident that Hagiwara invented Global Shutter Scheme of the three level clocking with MOS Capacitor Buffer Memory, clearly shown in JPA 1975-127646 and JPA 1975-127647. It is also evident that Hagiwara et al invented the Electrical Shutter Clocking Scheme by controlling punch-thru action of the in-pixel overflow drain (OFD) voltage as evidenced in JPA 1977-136885.

P+NP/Sub junction type Pinned Photo Diode

invented by Hagiwara at Sony in Japanese Patent 1975-134985.

| | | | |
|--------|-------------|--------|------------|
| File | 1975-134985 | Filed | 1975/11/10 |
| Public | 1975-058414 | Public | 1977/05/13 |
| | | Grant | 1983/10/19 |

Patent Claim in English Translation

(1) In the semiconductor substrate (Nsub), the first region (Pwell) of the first impurity type is formed, (2) on which, the second region (N) of the second impurity type is formed. (3) The charge (e-) from the light collecting part (N/Pwell Junction) is transferred to the adjacent charge transfer device (CTD). (4) Both are placed along the main surface of the semiconductor substrate. (5) In the solid state image sensor so defined, a rectifying Emitter junction (Je) is formed on the second region (N) of the light collecting part (N/Pwell), (6) forming a PNP Junction type transistor structure with the N/Pwell junction as Collector junction (Jc). (7) The charge, stored in the Base region (N) according to the illuminated light intensity, is transferred to the adjacent CTD. The solid state image sensor so defined is in the scope of this patent claim.

Light(Jc) VOD(Je)

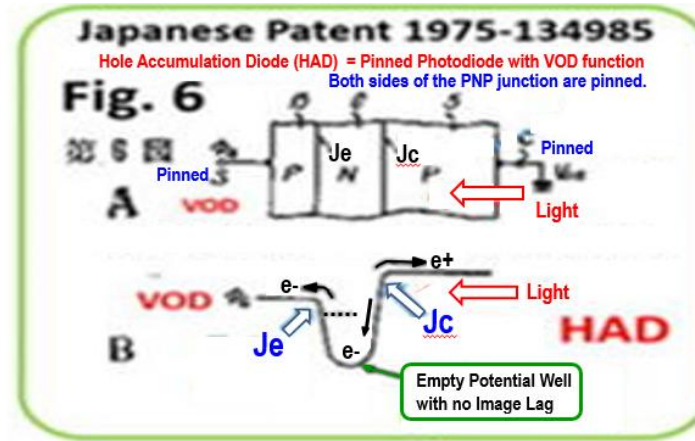

VOD (Je) type

Main Surface

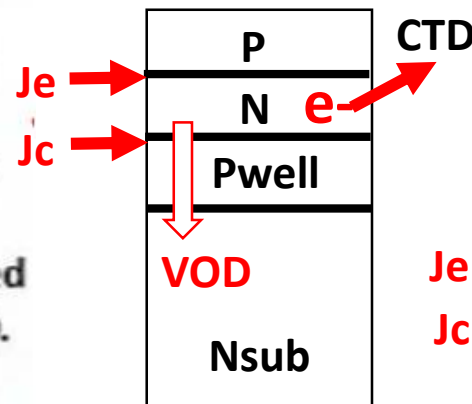

VOD (Jc) type

Main Surface

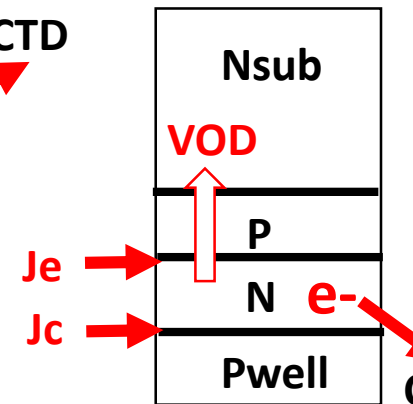

Hagiwara invented Pinned Photodiode (PPD).

Japanese Patent Applications, JPA1975-127646, JPA1975-127647 and JPA 1975-134985, filed by Yoshiaki Hagiwara at Sony in 1975, show that Hagiwara invented Buried Photodiode (BPD) with the Pinned Surface Hole Accumulation, Pinned Photodiode (PPD) and Hole Accumulation Diode (HAD). It is also evident that Hagiwara invented Global Shutter Scheme of the three level clocking with MOS Capacitor Buffer Memory, clearly shown in JPA 1975-127646 and JPA 1975-127647. It is also evident that Hagiwara et al invented the Electrical Shutter Clocking Scheme by controlling punch-through action of the in-pixel overflow drain (OFD) voltage as evidenced in JPA 1977-136885.

P+NP/Sub junction type Pinned Photo Diode

invented by Hagiwara at Sony in Japanese Patent 1975-134985.

| | | | |
|--------|-------------|--------|------------|
| File | 1975-134985 | Filed | 1975/11/10 |
| Public | 1975-058414 | Public | 1977/05/13 |
| | | Grant | 1983/10/19 |

Patent Claim in English Translation

(1) In the semiconductor substrate (Nsub),

Light(Jc) VOD(Je)

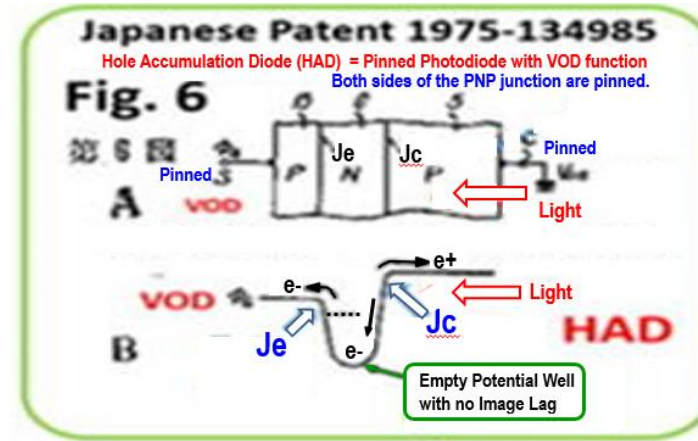

VOD (Je) type

VOD (Jc) type

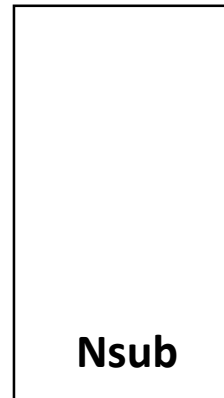

Hagiwara invented Pinned Photodiode (PPD).

Japanese Patent Applications, JPA1975-127646, JPA1975-127647 and JPA 1975-134985, filed by Yoshiaki Hagiwara at Sony in 1975, show that Hagiwara invented Buried Photodiode (BPD) with the Pinned Surface Hole Accumulation, Pinned Photodiode (PPD) and Hole Accumulation Diode (HAD). It is also evident that Hagiwara invented Global Shutter Scheme of the three level clocking with MOS Capacitor Buffer Memory, clearly shown in JPA 1975-127646 and JPA 1975-127647. It is also evident that Hagiwara et al invented the Electrical Shutter Clocking Scheme by controlling punch-thru action of the in-pixel overflow drain (OFD) voltage as evidenced in JPA 1977-136885.

P+NP/Sub junction type Pinned Photo Diode

invented by Hagiwara at Sony in Japanese Patent 1975-134985.

Light(Jc) VOD(Je)

| | | | |
|--------|-------------|--------|------------|
| File | 1975-134985 | Filed | 1975/11/10 |
| Public | 1975-058414 | Public | 1977/05/13 |
| | | Grant | 1983/10/19 |

Patent Claim in English Translation

(1) In the semiconductor substrate (Nsub), the first region(Pwell) of the first impurity type is formed,

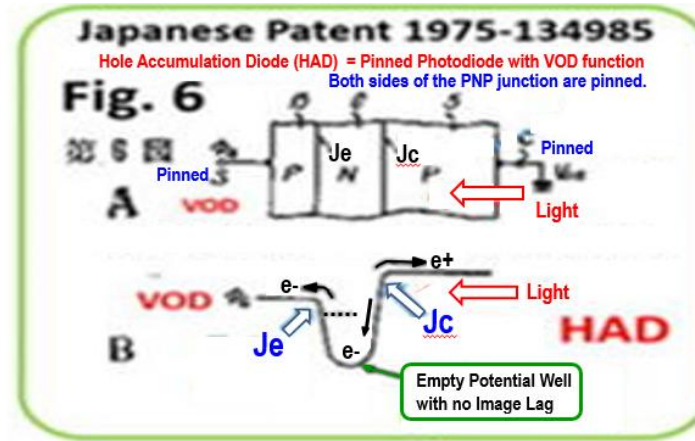

VOD (Je) type

VOD (Jc) type

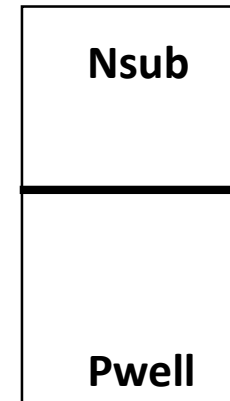
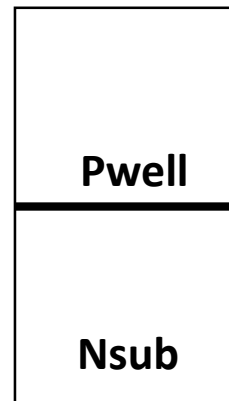

Hagiwara invented Pinned Photodiode (PPD).

Japanese Patent Applications, JPA1975-127646, JPA1975-127647 and JPA 1975-134985, filed by Yoshiaki Hagiwara at Sony in 1975, show that Hagiwara invented Buried Photodiode (BPD) with the Pinned Surface Hole Accumulation, Pinned Photodiode (PPD) and Hole Accumulation Diode (HAD). It is also evident that Hagiwara invented Global Shutter Scheme of the three level clocking with MOS Capacitor Buffer Memory, clearly shown in JPA 1975-127646 and JPA 1975-127647. It is also evident that Hagiwara et al invented the Electrical Shutter Clocking Scheme by controlling punch-thru action of the in-pixel overflow drain (OFD) voltage as evidenced in JPA 1977-136885.

P+NP/Sub junction type Pinned Photo Diode

invented by Hagiwara at Sony in Japanese Patent 1975-134985.

| | | | |
|--------|-------------|--------|------------|
| File | 1975-134985 | Filed | 1975/11/10 |
| Public | 1975-058414 | Public | 1977/05/13 |
| | | Grant | 1983/10/19 |

Patent Claim in English Translation

(1) In the semiconductor substrate (Nsub), the first region (Pwell) of the first impurity type is formed, (2) on which, the second region (N) of the second impurity type is formed.

Light(Jc) VOD(Je)

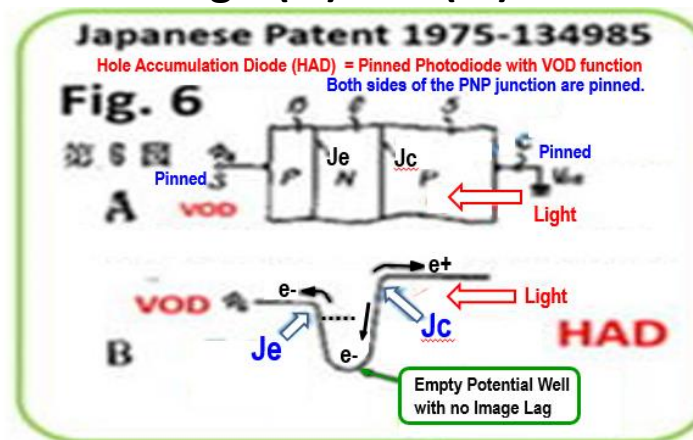

VOD (Je) type

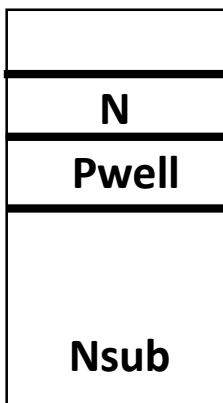

VOD (Jc) type

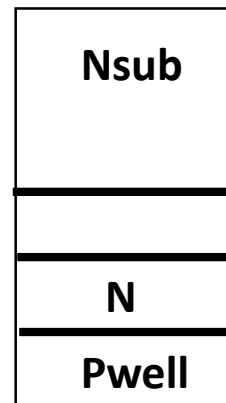

Hagiwara invented Pinned Photodiode (PPD).

Japanese Patent Applications, JPA1975-127646, JPA1975-127647 and JPA 1975-134985, filed by Yoshiaki Hagiwara at Sony in 1975, show that Hagiwara invented Buried Photodiode (BPD) with the Pinned Surface Hole Accumulation, Pinned Photodiode (PPD) and Hole Accumulation Diode (HAD). It is also evident that Hagiwara invented Global Shutter Scheme of the three level clocking with MOS Capacitor Buffer Memory, clearly shown in JPA 1975-127646 and JPA 1975-127647. It is also evident that Hagiwara et al invented the Electrical Shutter Clocking Scheme by controlling punch-thru action of the in-pixel overflow drain (OFD) voltage as evidenced in JPA 1977-136885.

P+NP/Sub junction type Pinned Photo Diode

invented by Hagiwara at Sony in Japanese Patent 1975-134985.

| | | | |
|--------|-------------|--------|------------|
| File | 1975-134985 | Filed | 1975/11/10 |
| Public | 1975-058414 | Public | 1977/05/13 |
| | | Grant | 1983/10/19 |

Patent Claim in English Translation

(1) In the semiconductor substrate (Nsub), the first region (Pwell) of the first impurity type is formed, (2) on which, the second region (N) of the second impurity type is formed. (3) The charge (e-) from the light collecting part (N/Pwell Junction) is transferred to the adjacent charge transfer device (CTD).

Light(Jc) VOD(Je)

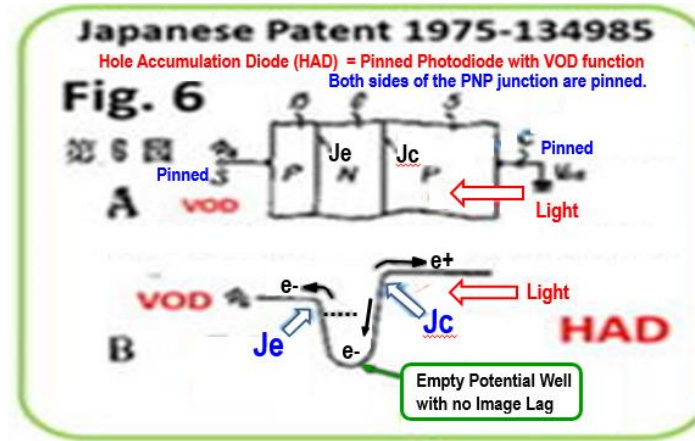

VOD (Je) type

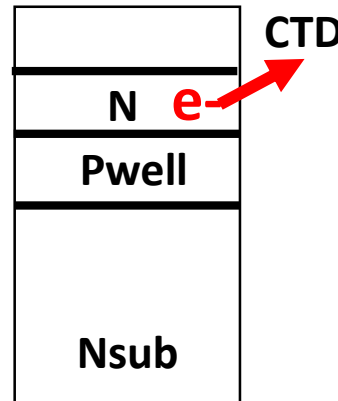

VOD (Jc) type

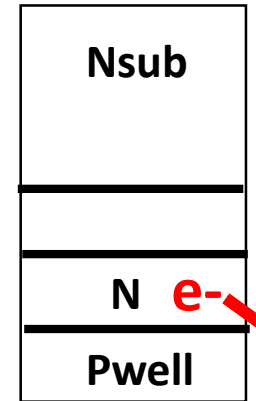

Hagiwara invented Pinned Photodiode (PPD).

Japanese Patent Applications, JPA1975-127646, JPA1975-127647 and JPA 1975-134985, filed by Yoshiaki Hagiwara at Sony in 1975, show that Hagiwara invented Buried Photodiode (BPD) with the Pinned Surface Hole Accumulation, Pinned Photodiode (PPD) and Hole Accumulation Diode (HAD). It is also evident that Hagiwara invented Global Shutter Scheme of the three level clocking with MOS Capacitor Buffer Memory, clearly shown in JPA 1975-127646 and JPA 1975-127647. It is also evident that Hagiwara et al invented the Electrical Shutter Clocking Scheme by controlling punch-thru action of the in-pixel overflow drain (OFD) voltage as evidenced in JPA 1977-136885.

P+NP/Sub junction type Pinned Photo Diode

invented by Hagiwara at Sony in Japanese Patent 1975-134985.

| | | | |
|--------|-------------|--------|------------|
| File | 1975-134985 | Filed | 1975/11/10 |
| Public | 1975-058414 | Public | 1977/05/13 |
| | | Grant | 1983/10/19 |

Patent Claim in English Translation

(1) In the semiconductor substrate (Nsub), the first region (Pwell) of the first impurity type is formed, (2) on which, the second region (N) of the second impurity type is formed. (3) The charge (e-) from the light collecting part (N/Pwell Junction) is transferred to the adjacent charge transfer device (CTD). (4) Both are placed along the main surface of the semiconductor substrate.

Light(Jc) VOD(Je)

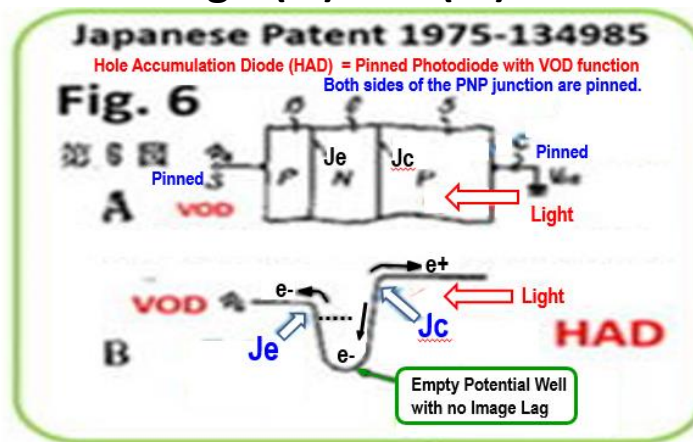

VOD (Je) type

Main Surface

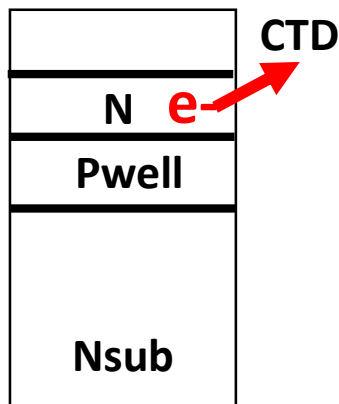

VOD (Jc) type

Nsub

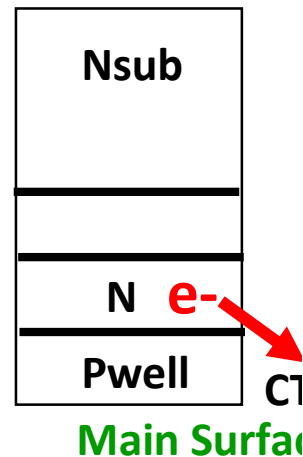

Hagiwara invented Pinned Photodiode (PPD).

Japanese Patent Applications, JPA1975-127646, JPA1975-127647 and JPA 1975-134985, filed by Yoshiaki Hagiwara at Sony in 1975, show that Hagiwara invented Buried Photodiode (BPD) with the Pinned Surface Hole Accumulation, Pinned Photodiode (PPD) and Hole Accumulation Diode (HAD). It is also evident that Hagiwara invented Global Shutter Scheme of the three level clocking with MOS Capacitor Buffer Memory, clearly shown in JPA 1975-127646 and JPA 1975-127647. It is also evident that Hagiwara et al invented the Electrical Shutter Clocking Scheme by controlling punch-thru action of the in-pixel overflow drain (OFD) voltage as evidenced in JPA 1977-136885.

P+NP/Sub junction type Pinned Photo Diode

invented by Hagiwara at Sony in Japanese Patent 1975-134985.

| | | | |
|--------|-------------|--------|------------|
| File | 1975-134985 | Filed | 1975/11/10 |
| Public | 1975-058414 | Public | 1977/05/13 |
| | | Grant | 1983/10/19 |

Patent Claim in English Translation

(1) In the semiconductor substrate (Nsub), the first region (Pwell) of the first impurity type is formed, (2) on which, the second region (N) of the second impurity type is formed. (3) The charge (e-) from the light collecting part (N/Pwell Junction) is transferred to the adjacent charge transfer device (CTD). (4) Both are placed along the main surface of the semiconductor substrate. (5) In the solid state image sensor so defined, a rectifying Emitter junction (Je) is formed on the second region (N) of the light collecting part (N/Pwell),

Light(Jc) VOD(Je)

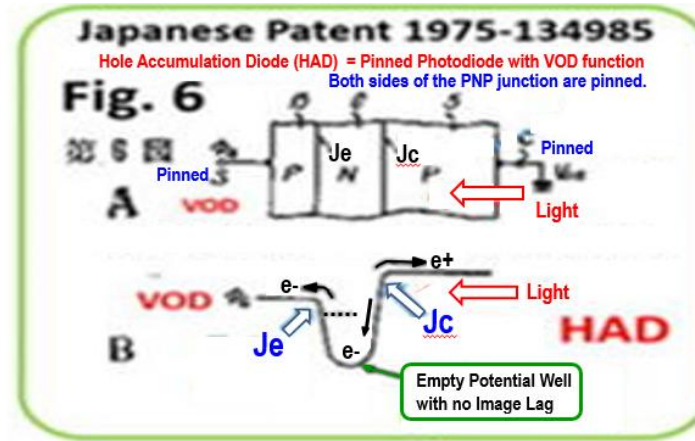

VOD (Je) type

Main Surface

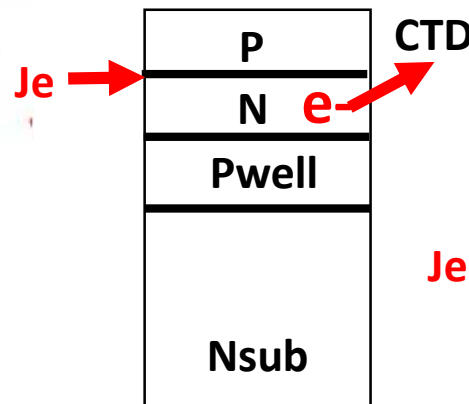

VOD (Jc) type

Main Surface

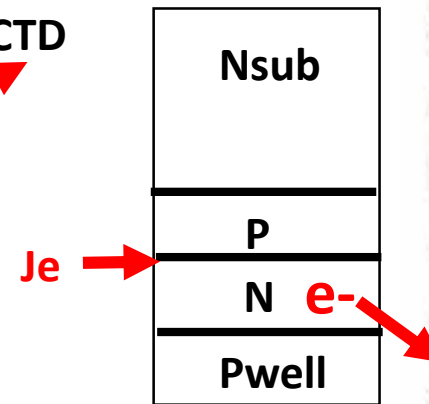

Hagiwara invented Pinned Photodiode (PPD).

Japanese Patent Applications, JPA1975-127646, JPA1975-127647 and JPA 1975-134985, filed by Yoshiaki Hagiwara at Sony in 1975, show that Hagiwara invented Buried Photodiode (BPD) with the Pinned Surface Hole Accumulation, Pinned Photodiode (PPD) and Hole Accumulation Diode (HAD). It is also evident that Hagiwara invented Global Shutter Scheme of the three level clocking with MOS Capacitor Buffer Memory, clearly shown in JPA 1975-127646 and JPA 1975-127647. It is also evident that Hagiwara et al invented the Electrical Shutter Clocking Scheme by controlling punch-thru action of the in-pixel overflow drain (OFD) voltage as evidenced in JPA 1977-136885.

P+NP/Sub junction type Pinned Photo Diode

invented by Hagiwara at Sony in Japanese Patent 1975-134985.
Light(Jc) VOD(Je)

| | | | |
|--------|-------------|--------|------------|
| File | 1975-134985 | Filed | 1975/11/10 |
| Public | 1975-058414 | Public | 1977/05/13 |
| | | Grant | 1983/10/19 |

Patent Claim in English Translation

(1) In the semiconductor substrate (Nsub), the first region (Pwell) of the first impurity type is formed, (2) on which, the second region (N) of the second impurity type is formed. (3) The charge (e-) from the light collecting part (N/Pwell Junction) is transferred to the adjacent charge transfer device (CTD). (4) Both are placed along the main surface of the semiconductor substrate. (5) In the solid stare image sensor so defined, a rectifying Emitter junction (Je) is formed on the second region (N) of the light collecting part (N/Pwell), (6) forming a PNP Junction type transistor structure with the N/Pwell junction as Collector junction (Jc).

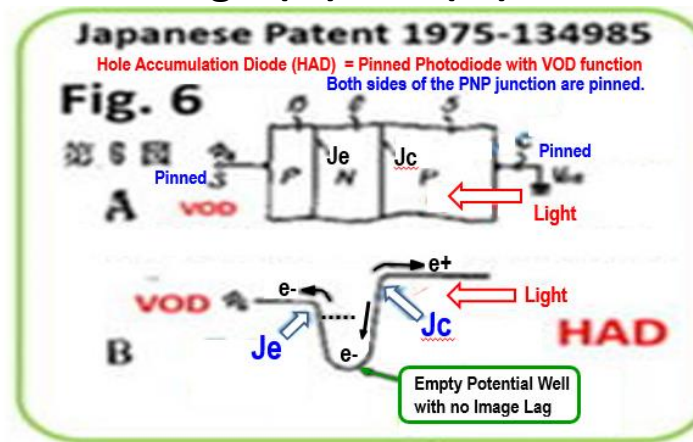

VOD (Je) type

VOD (Jc) type

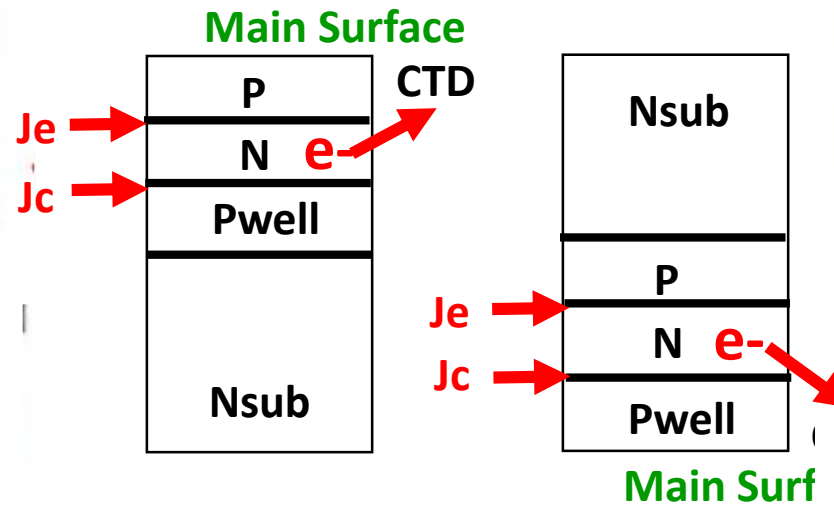

Hagiwara invented Pinned Photodiode (PPD).

Japanese Patent Applications, JPA1975-127646, JPA1975-127647 and JPA 1975-134985, filed by Yoshiaki Hagiwara at Sony in 1975, show that Hagiwara invented Buried Photodiode (BPD) with the Pinned Surface Hole Accumulation, Pinned Photodiode (PPD) and Hole Accumulation Diode (HAD). It is also evident that Hagiwara invented Global Shutter Scheme of the three level clocking with MOS Capacitor Buffer Memory, clearly shown in JPA 1975-127646 and JPA 1975-127647. It is also evident that Hagiwara et al invented the Electrical Shutter Clocking Scheme by controlling punch-thru action of the in-pixel overflow drain (OFD) voltage as evidenced in JPA 1977-136885.

P+NP/Sub junction type Pinned Photo Diode

invented by Hagiwara at Sony in Japanese Patent 1975-134985.
Light(Jc) VOD(Je)

| | | | |
|--------|-------------|--------|------------|
| File | 1975-134985 | Filed | 1975/11/10 |
| Public | 1975-058414 | Public | 1977/05/13 |
| | | Grant | 1983/10/19 |

Patent Claim in English Translation

(1) In the semiconductor substrate (Nsub), the first region (Pwell) of the first impurity type is formed, (2) on which, the second region (N) of the second impurity type is formed. (3) The charge (e-) from the light collecting part (N/Pwell Junction) is transferred to the adjacent charge transfer device (CTD). (4) Both are placed along the main surface of the semiconductor substrate. (5) In the solid state image sensor so defined, a rectifying Emitter junction (Je) is formed on the second region (N) of the light collecting part (N/Pwell), (6) forming a PNP Junction type transistor structure with the N/Pwell junction as Collector junction (Jc). (7) The charge, stored in the Base region (N) according to the illuminated light intensity, is transferred to the adjacent CTD. The solid state image sensor so defined is in the scope of this patent claim.

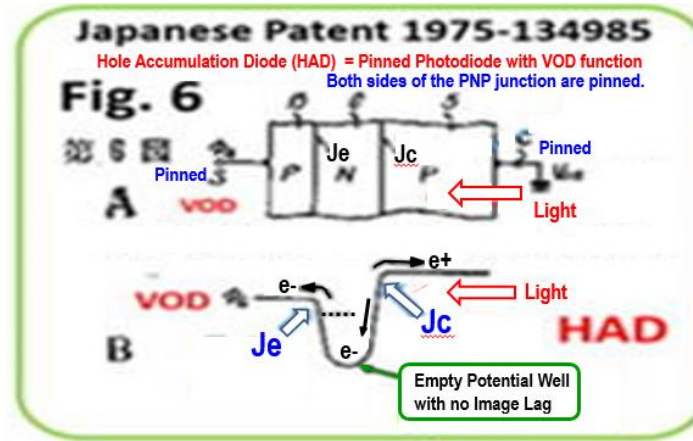

VOD (Je) type

VOD (Jc) type

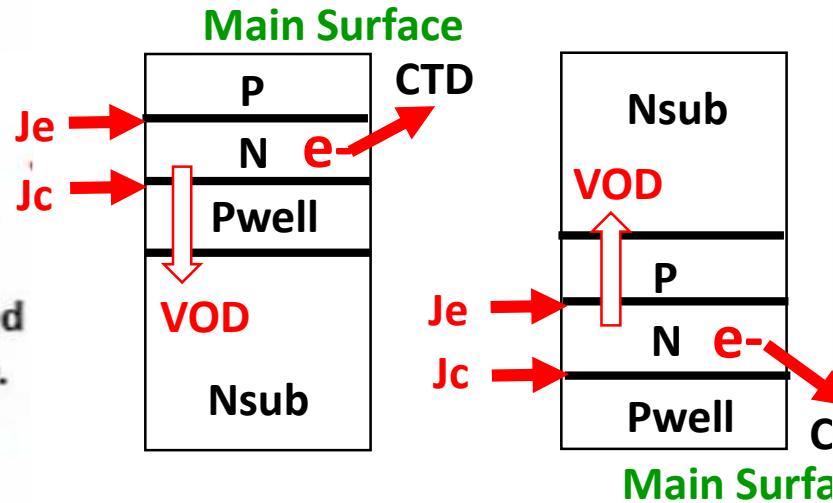

Hagiwara invented Pinned Photodiode (PPD).

Japanese Patent Applications, JPA1975-127646, JPA1975-127647 and JPA 1975-134985, filed by Yoshiaki Hagiwara at Sony in 1975, show that Hagiwara invented Buried Photodiode (BPD) with the Pinned Surface Hole Accumulation, Pinned Photodiode (PPD) and Hole Accumulation Diode (HAD). It is also evident that Hagiwara invented Global Shutter Scheme of the three level clocking with MOS Capacitor Buffer Memory, clearly shown in JPA 1975-127646 and JPA 1975-127647. It is also evident that Hagiwara et al invented the Electrical Shutter Clocking Scheme by controlling punch-thru action of the in-pixel overflow drain (OFD) voltage as evidenced in JPA 1977-136885.

P+NP/Sub junction type Pinned Photo Diode

invented by Hagiwara at Sony in Japanese Patent 1975-134985.

Light(Jc) VOD(Je)

VOD (Je) type

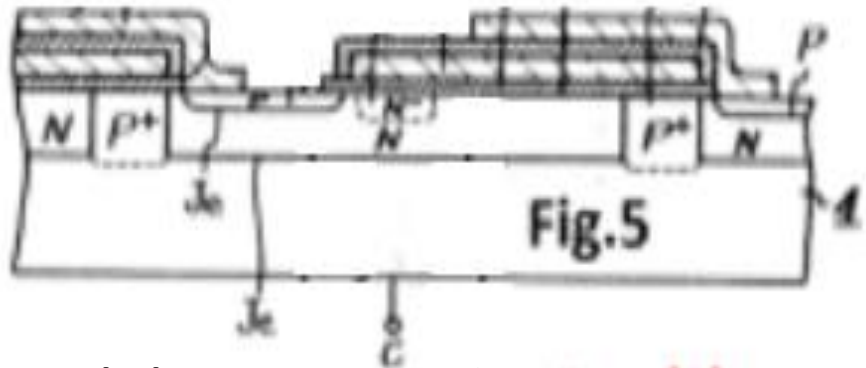

Light(Je) Je side is used for light illumination
VOD(Jc) Jc side is used for VOD action

VOD (Jc) type

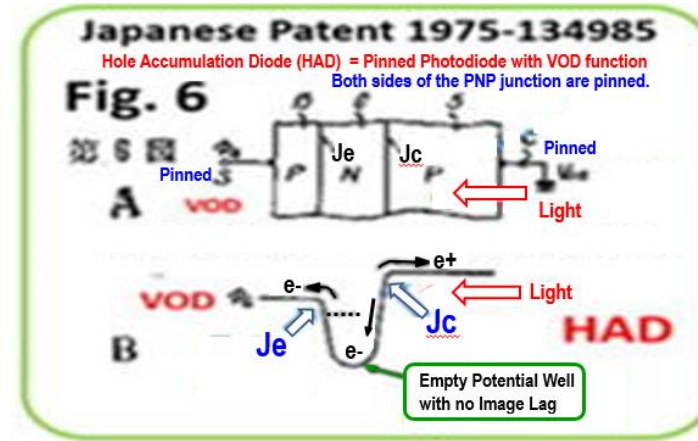

Hagiwara invented Pinned Photodiode (PPD).

Japanese Patent Applications, JPA1975-127646, JPA1975-127647 and JPA 1975-134985, filed by Yoshiaki Hagiwara at Sony in 1975, show that Hagiwara invented Buried Photodiode (BPD) with the Pinned Surface Hole Accumulation, Pinned Photodiode (PPD) and Hole Accumulation Diode (HAD). It is also evident that Hagiwara invented Global Shutter Scheme of the three level clocking with MOS Capacitor Buffer Memory, clearly shown in JPA 1975-127646 and JPA 1975-127647. It is also evident that Hagiwara et al invented the Electrical Shutter Clocking Scheme by controlling punch-thru action of the in-pixel overflow drain (OFD) voltage as evidenced in JPA 1977-136885.

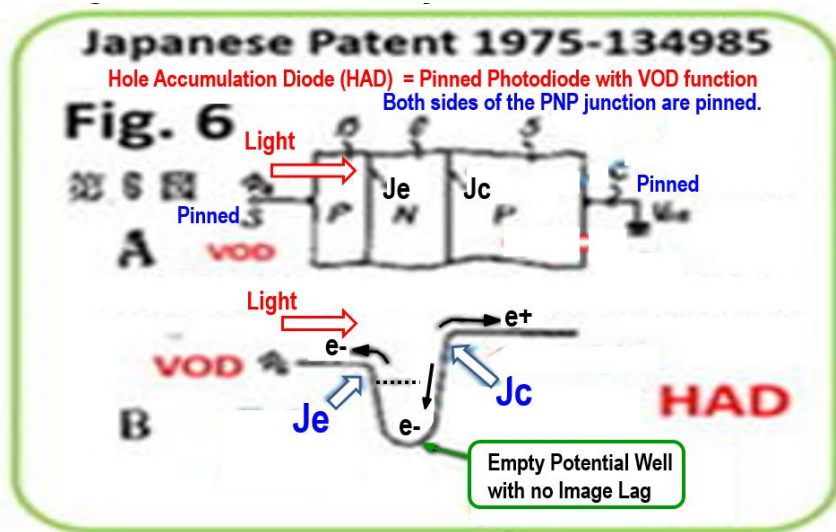

VOD (Je) type

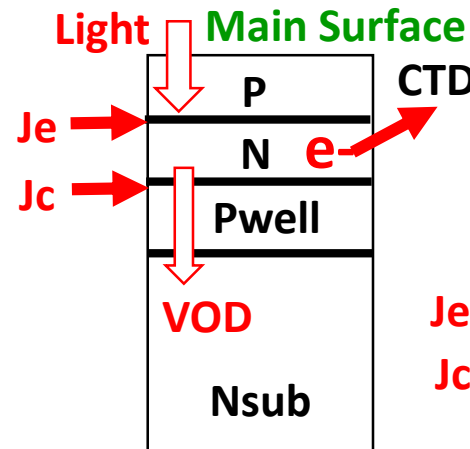

VOD (Jc) type

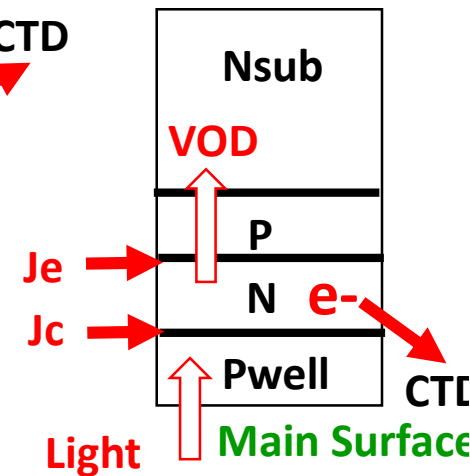

Finally the Sony-Fairchild Patent War(1991-2000) ended over the Sony HAD Sensor which is identical to the P+NPNsub junction type Pinned Photodiode with Vertical Overflow Drain, originally invented by Hagiwara at Sony in 1975.

And finally Hagiwara received for his 1975-134985 Japanese Patent officially, the First Patent Award from Mr. Ando, Sony president in April, 2001 after more 26 years of struggles since his invention.

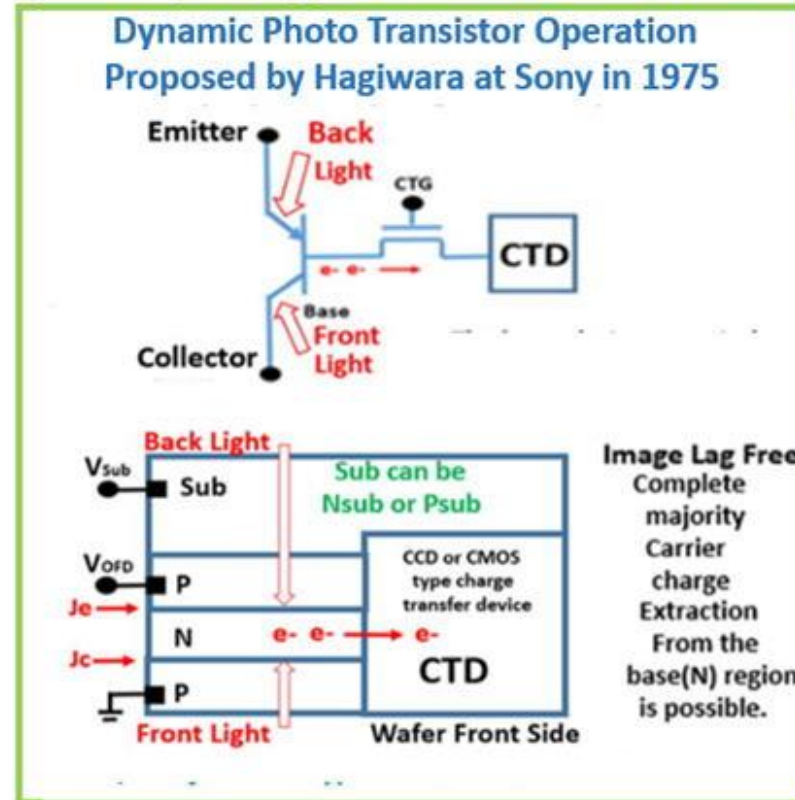

Hagiwara invented Pinned Photodiode (PPD).

Japanese Patent Applications, JPA1975-127646, JPA1975-127647 and JPA 1975-134985, filed by Yoshiaki Hagiwara at Sony in 1975, show that Hagiwara invented Buried Photodiode (BPD) with the Pinned Surface Hole Accumulation, Pinned Photodiode (PPD) and Hole Accumulation Diode (HAD). It is also evident that Hagiwara invented Global Shutter Scheme of the three level clocking with MOS Capacitor Buffer Memory, clearly shown in JPA 1975-127646 and JPA 1975-127647. It is also evident that Hagiwara et al invented the Electrical Shutter Clocking Scheme by controlling punch-thru action of the in-pixel overflow drain (OFD) voltage as evidenced in JPA 1977-136885.

Japanese Patent JPA 1977-126885 on Electrical Shutter Clocking Scheme invented by Y. Hagiwara, S. Ochi and T. Hashimoto in 1977.

Fig. 3 CCD/MOS Photo Capacitor

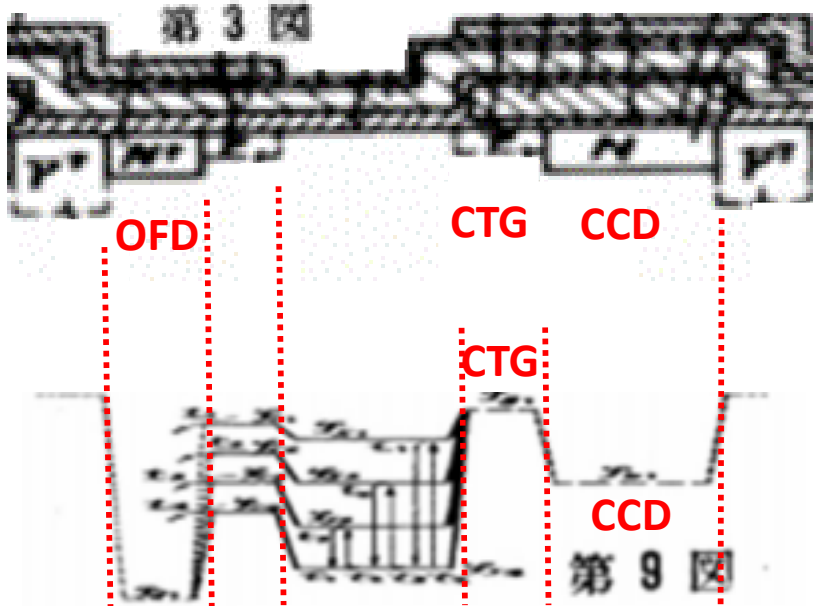

Fig. 8 Gamma Control Mode

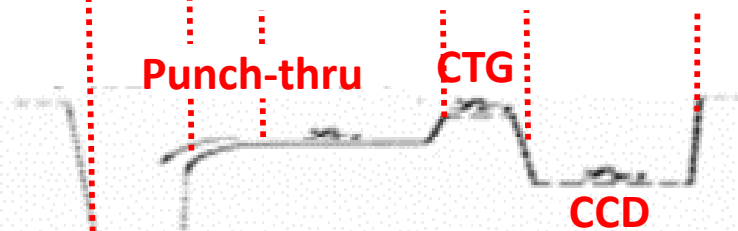
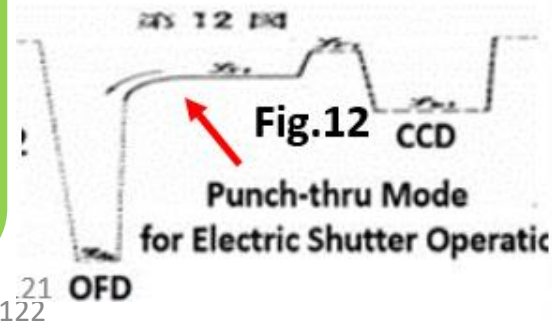
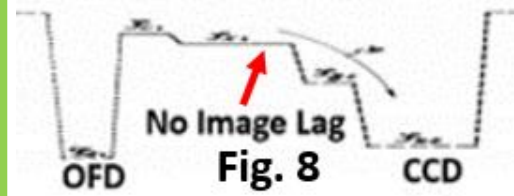
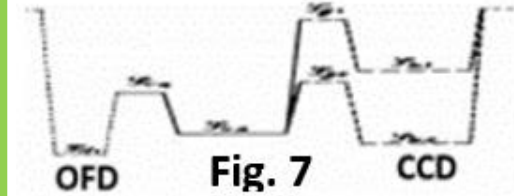
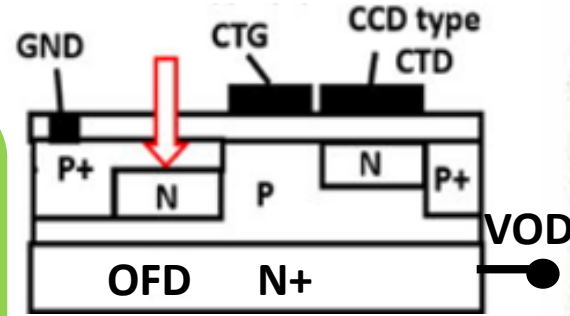

Fig. 12 Electric Shutter Mode

Complete Charge Transfer and no image lag

Pinned Photodiode with VOD fu



The electric shutter clocking scheme with the complete draining of signal charge with the no image lag feature can be achieved by controlling the overflow drain (OFD) punch-thru voltage.

Hagiwara invented Pinned Photodiode (PPD).

Japanese Patent Applications, JPA1975-127646, JPA1975-127647 and JPA 1975-134985, filed by Yoshiaki Hagiwara at Sony in 1975, show that Hagiwara invented Buried Photodiode (BPD) with the Pinned Surface Hole Accumulation, Pinned Photodiode (PPD) and Hole Accumulation Diode (HAD). It is also evident that Hagiwara invented Global Shutter Scheme of the three level clocking with MOS Capacitor Buffer Memory, clearly shown in JPA 1975-127646 and JPA 1975-127647. It is also evident that Hagiwara et al invented the Electrical Shutter Clocking Scheme by controlling punch-thru action of the in-pixel overflow drain (OFD) voltage as evidenced in JPA 1977-136885.

The Pinned Photodiode (Sony Original HAD sensor) Structure

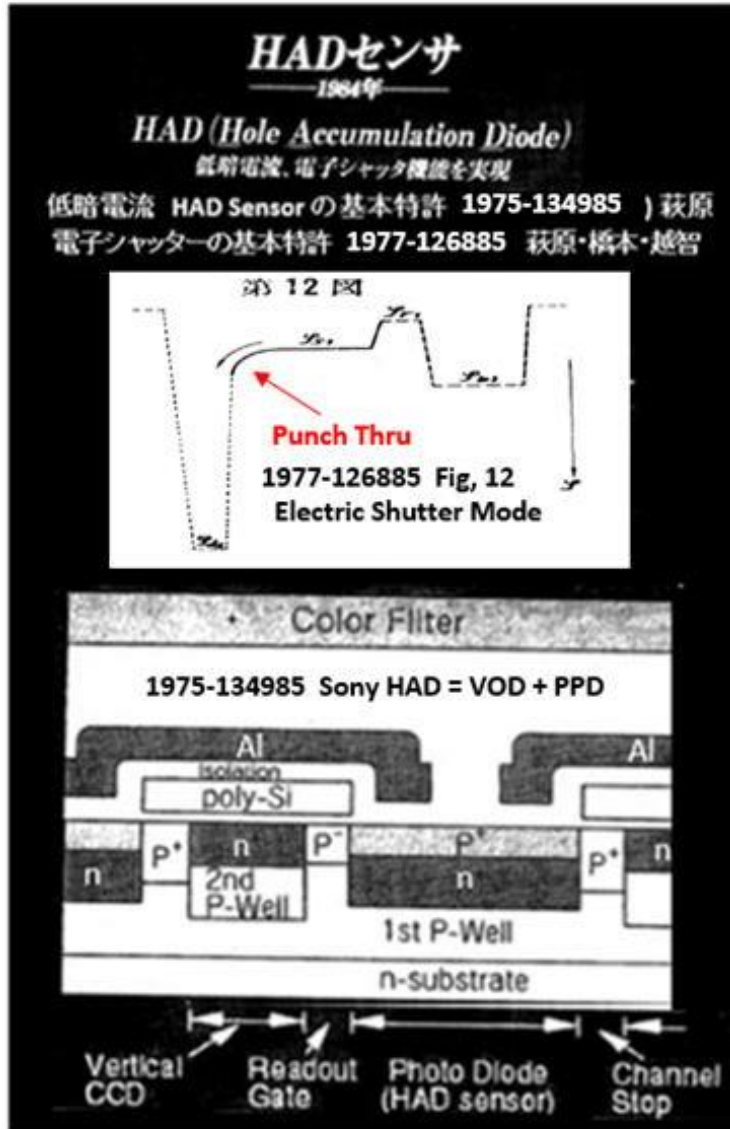

(from SONY Product Catalog)

Electric Shutter Basic Patent Award
from Sony President Idei to Yoshiaki Hagiwara
for Japanese Patent 1977-126885 by Hagiwara



Hagiwara invented Pinned Photodiode (PPD).

Japanese Patent Applications, JPA1975-127646, JPA1975-127647 and JPA 1975-134985, filed by Yoshiaki Hagiwara at Sony in 1975, show that Hagiwara invented Buried Photodiode (BPD) with the Pinned Surface Hole Accumulation, Pinned Photodiode (PPD) and Hole Accumulation Diode (HAD). It is also evident that Hagiwara invented Global Shutter Scheme of the three level clocking with MOS Capacitor Buffer Memory, clearly shown in JPA 1975-127646 and JPA 1975-127647. It is also evident that Hagiwara et al invented the Electrical Shutter Clocking Scheme by controlling punch-thru action of the in-pixel overflow drain (OFD) voltage as evidenced in JPA 1977-136885.

P+P Doping Slope Barrier Potential V_B

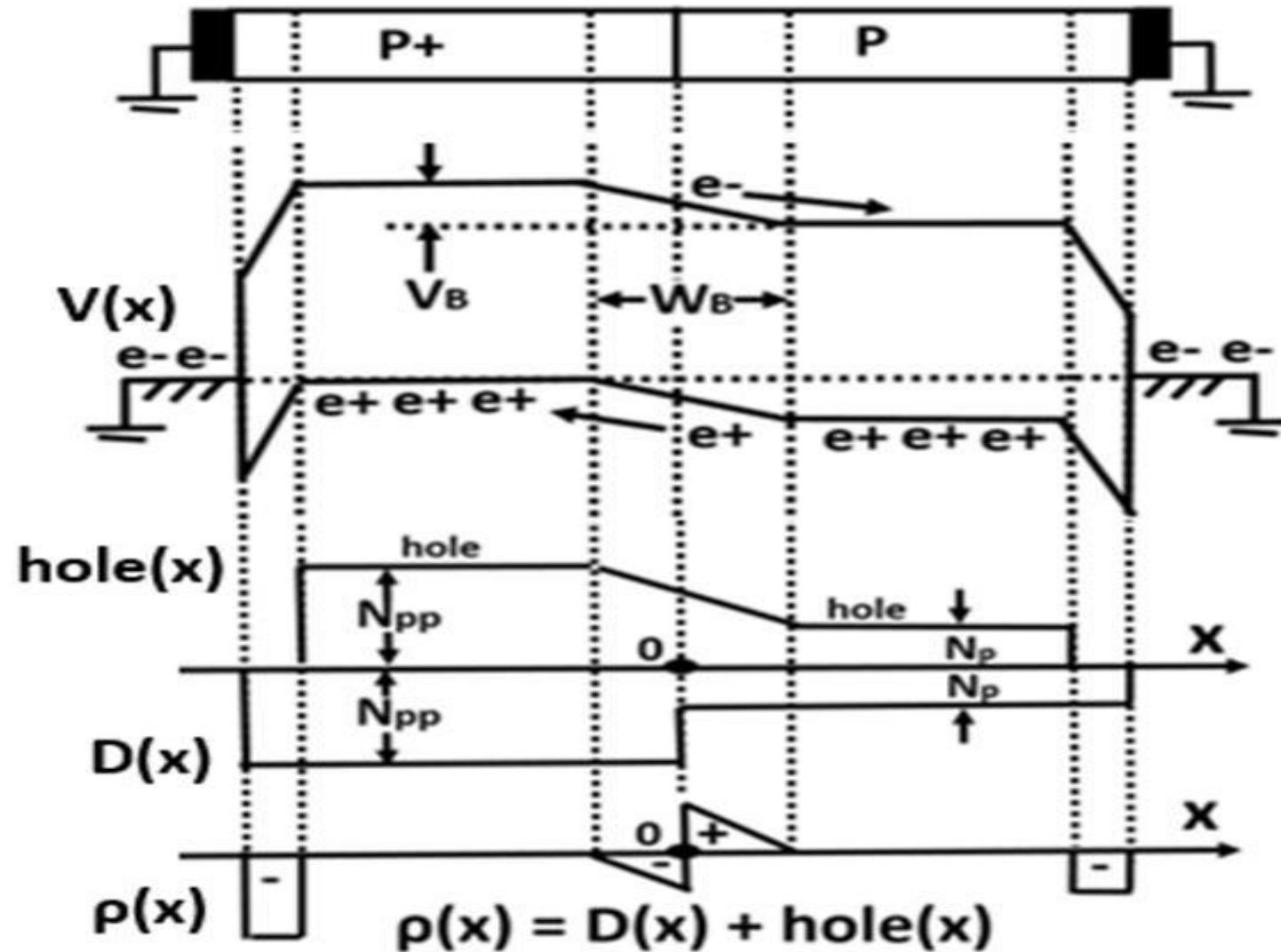

Hagiwara invented Pinned Photodiode (PPD).

Japanese Patent Applications, JPA1975-127646, JPA1975-127647 and JPA 1975-134985, filed by Yoshiaki Hagiwara at Sony in 1975, show that Hagiwara invented Buried Photodiode (BPD) with the Pinned Surface Hole Accumulation, Pinned Photodiode (PPD) and Hole Accumulation Diode (HAD). It is also evident that Hagiwara invented Global Shutter Scheme of the three level clocking with MOS Capacitor Buffer Memory, clearly shown in JPA 1975-127646 and JPA 1975-127647. It is also evident that Hagiwara et al invented the Electrical Shutter Clocking Scheme by controlling punch-thru action of the in-pixel overflow drain (OFD) voltage as evidenced in JPA 1977-136885.

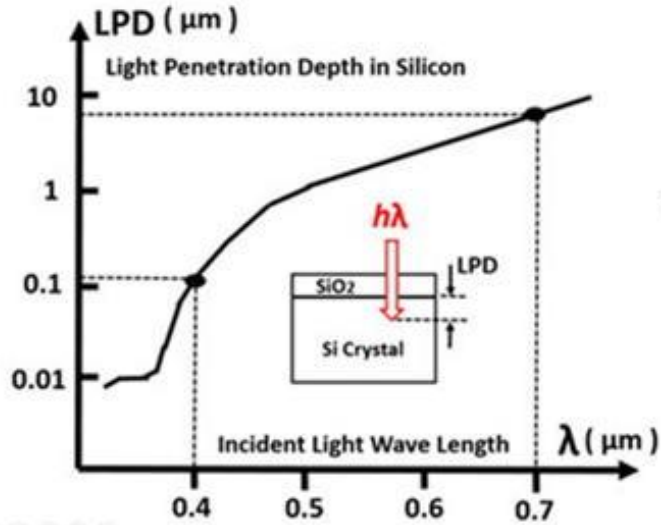

Drift Field Transistor

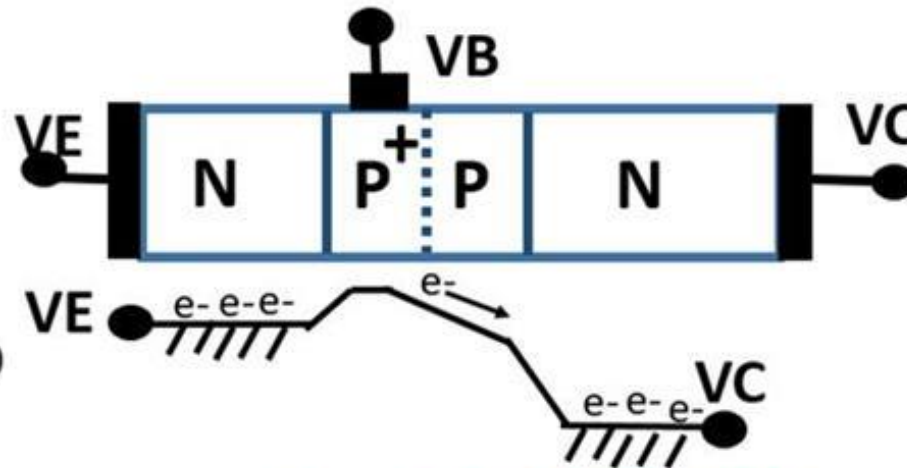

Hagiwara invented Pinned Photodiode (PPD).

Japanese Patent Applications, JPA1975-127646, JPA1975-127647 and JPA 1975-134985, filed by Yoshiaki Hagiwara at Sony in 1975, show that Hagiwara invented Buried Photodiode (BPD) with the Pinned Surface Hole Accumulation, Pinned Photodiode (PPD) and Hole Accumulation Diode (HAD). It is also evident that Hagiwara invented Global Shutter Scheme of the three level clocking with MOS Capacitor Buffer Memory, clearly shown in JPA 1975-127646 and JPA 1975-127647. It is also evident that Hagiwara et al invented the Electrical Shutter Clocking Scheme by controlling punch-thru action of the in-pixel overflow drain (OFD) voltage as evidenced in JPA 1977-136885.

Figure 7 of JAP 1975-127647



Figure 6 of JAP 1975-134985

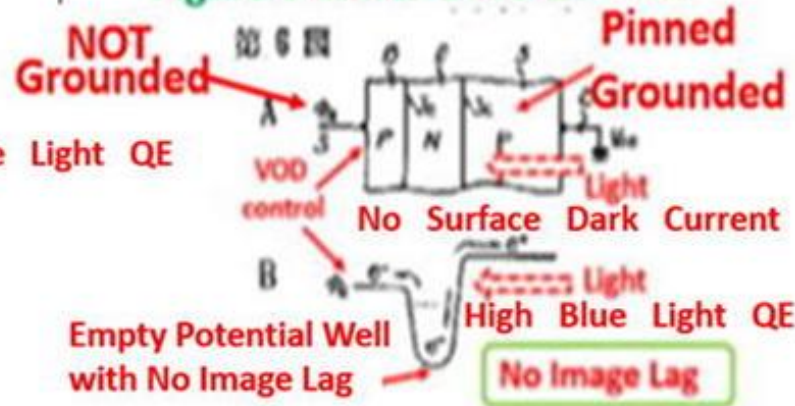

Hagiwara invented PNP junction type PPD in 1975 with (1) blue light 100% QE, (2) No Surface Dark Current and (3) No Image Lag, Complete Charge Transfer features.

Japanese Patent 1975-127646

N+NP+NP junction type Buried Pinned Photodiode with Built-in MOS Capacitor Buffer Memory Global Shutter Function and the surface N+N doping slope Barrier Electric Field Photo Pair Generation

The First Japanese PPD Patent Application JPA 1975-127646 was applied for the back light illumination type Pinned Photodiode (PPD) image sensors with the CCD/MOS capacitor type buffer memory for Global Shutter Function which is a very important function needed for Modern CMOS Image Sensors.

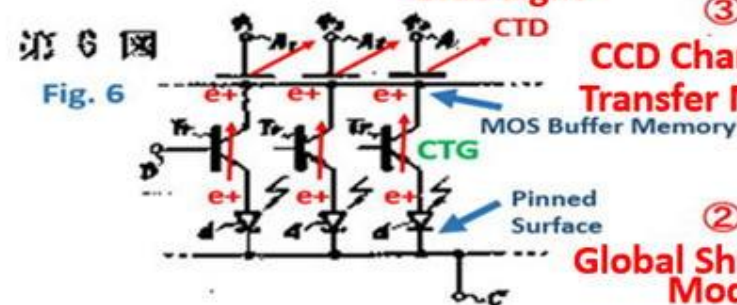
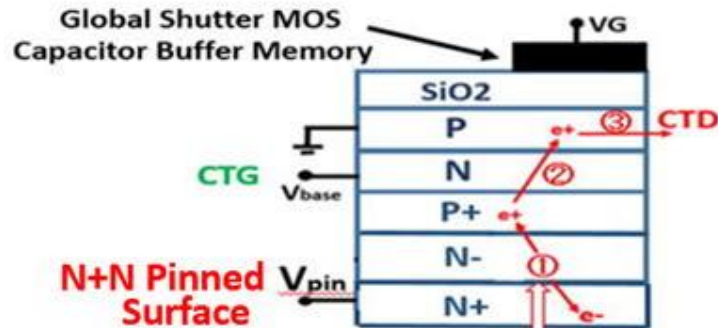

Double Junction Dynamic Photo Transistor (PPD) invented in 1975 by Hagiwara at Sony.

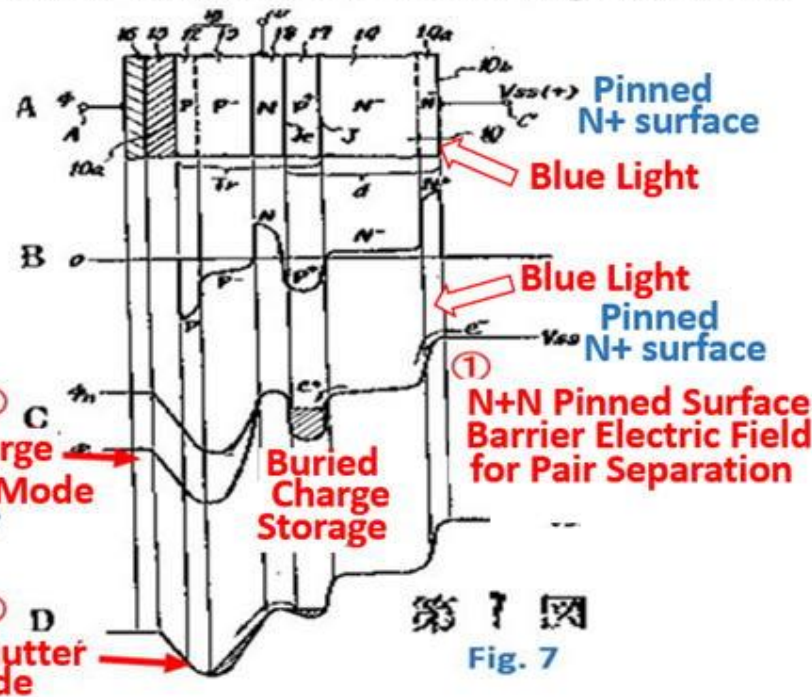

Triple Junction Dynamic Photo Thyristor (HAD) invented in 1975 by Hagiwara at Sony.

See Japanese Patent Application JPA 1975-127646, 1975-127647 and 1975-134985

Hagiwara invented Pinned Photodiode (PPD).

Japanese Patent Applications, JPA1975-127646, JPA1975-127647 and JPA 1975-134985, filed by Yoshiaki Hagiwara at Sony in 1975, show that Hagiwara invented Buried Photodiode (BPD) with the Pinned Surface Hole Accumulation, Pinned Photodiode (PPD) and Hole Accumulation Diode (HAD). It is also evident that Hagiwara invented Global Shutter Scheme of the three level clocking with MOS Capacitor Buffer Memory, clearly shown in JPA 1975-127646 and JPA 1975-127647. It is also evident that Hagiwara et al invented the Electrical Shutter Clocking Scheme by controlling punch-thru action of the in-pixel overflow drain (OFD) voltage as evidenced in JPA 1977-136885.

Global Shutter Mode

Japanese Patent 1975-127647

**Complete Charge Transfer Mode
No Image Lag**

N+NP+N junction type Buried Pinned Photodiode with Built-in MOS Capacitor Buffer Memory Global Shutter Function and the surface N+N doping slope Barrier Electric Field Photo Pair Generation

This Japanese PPD Patent Application JPA 1975-127647 was also applied for the back light illumination type Pinned Photodiode (PPD) image sensors with the CCD/MOS capacitor type buffer memory for Global Shutter Function which is a very important function needed for Modern CMOS Image Sensors.

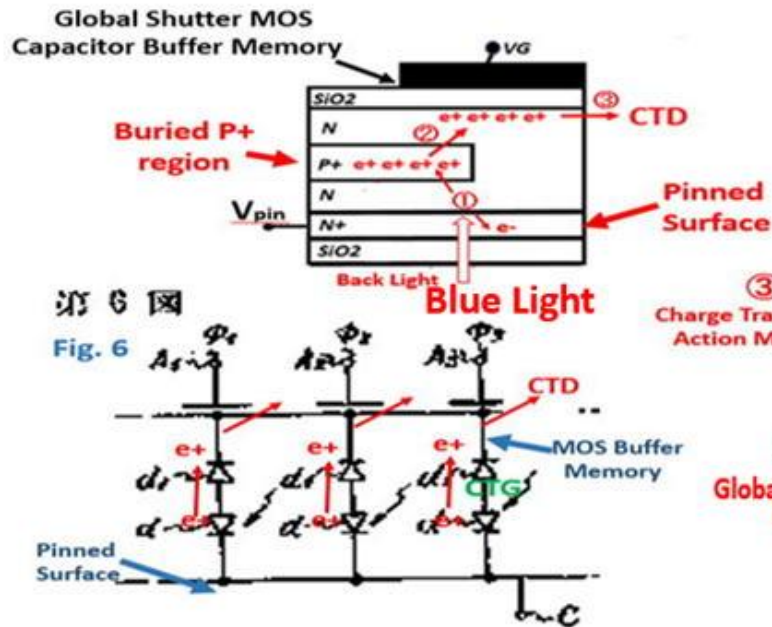

Double Junction Dynamic Photo Transistor (PPD) invented in 1975 by Hagiwara at Sony.

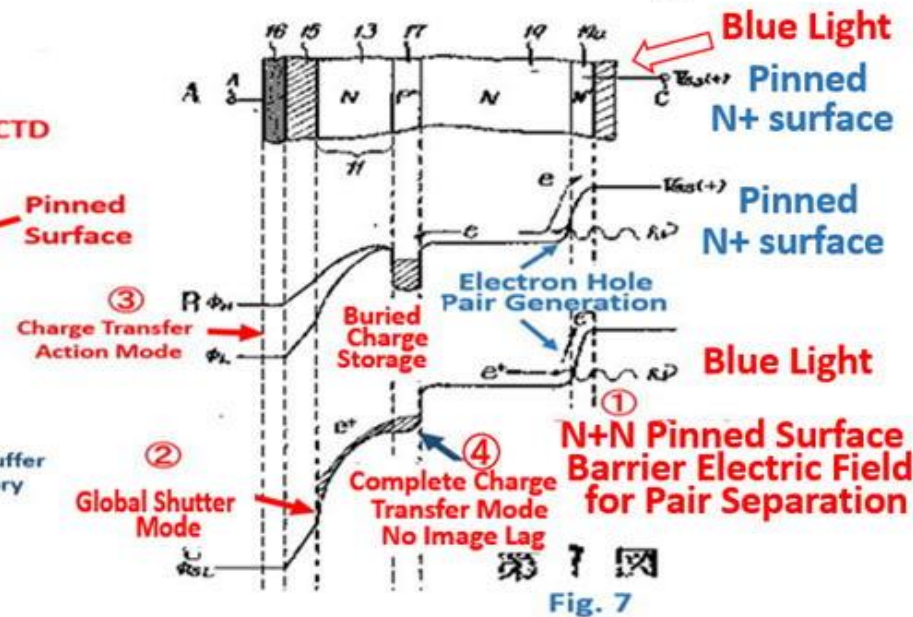

Triple Junction Dynamic Photo Thyristor (HAD) invented in 1975 by Hagiwara at Sony.

See Japanese Patent Application JPA 1975-127646, 1975-127647 and 1975-134985

Hagiwara invented Pinned Photodiode (PPD).

Japanese Patent Applications, JPA1975-127646, JPA1975-127647 and JPA 1975-134985, filed by Yoshiaki Hagiwara at Sony in 1975, show that Hagiwara invented Buried Photodiode (BPD) with the Pinned Surface Hole Accumulation, Pinned Photodiode (PPD) and Hole Accumulation Diode (HAD). It is also evident that Hagiwara invented Global Shutter Scheme of the three level clocking with MOS Capacitor Buffer Memory, clearly shown in JPA 1975-127646 and JPA 1975-127647. It is also evident that Hagiwara et al invented the Electrical Shutter Clocking Scheme by controlling punch-thru action of the in-pixel overflow drain (OFD) voltage as evidenced in JPA 1977-136885.

Japanese Patent 1975-134985

Pinned Photodiode and Sony Hole Accumulation Diode (HAD)

Pinned Surface Double Junction P+NP Dynamic Photo Transistor in the silicon substrate (Nsub)
Pinned Photodiode with the vertical overflow drain (VOD) function in the silicon substrate (Nsub)

PNPN junction Transistor type Pinned Photodiode

Visit <https://www.j-platpat.inpit.go.jp/> and put the patent number **1975-134985**

| | | | |
|--------|-------------|--------|------------|
| File | 1975-134985 | Filed | 1975/11/10 |
| Public | 1975-058414 | Public | 1977/05/13 |
| | | Grant | 1983/10/19 |

Patent Claim in English Translation

(1) In the semiconductor substrate (Nsub), the first region (P1) of the first impurity type is formed, (2) on which, the second region (N) of the second impurity type is formed. (3) The charge (e-) from the light collecting part (N) is transferred to the adjacent charge transfer device (CTD). (4) Both are placed along the main surface of the semiconductor substrate. (5) In the solid state image sensor so defined, a rectifying Emitter junction (Je) is formed on the second region (N) of the light collecting part (N). And (6) Collector junction (Jc) is formed by the second region (N) and the first region (P1), forming a transistor structure (P2NP1) (7) Photo charge is stored in the Base region (N) according to the illuminated light intensity, and transferred to the adjacent CTD. The solid state image sensor so defined is in the scope of this patent claim. VOD may be grounded. Light

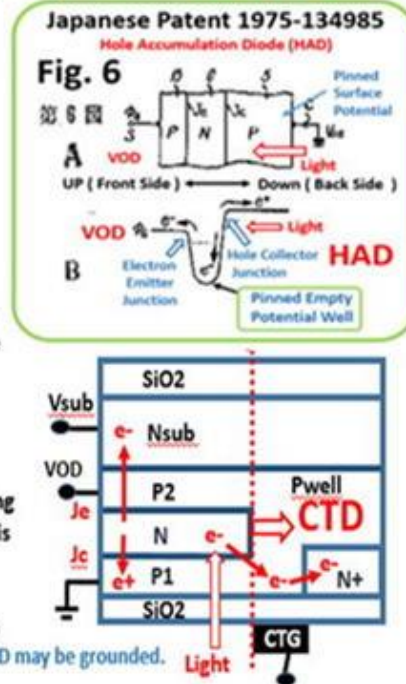

Most CCD Image sensors and CMOS Image sensors today are applied with the combination of the vertical overflow drain (VOD) and Pinned Photodiode.

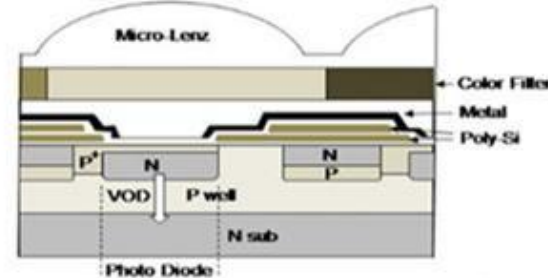

In 1975 Yoshiaki Hagiwara at Sony proposed using a PNP transistor as the photodetector which is the combination of the VOD and Pinned Photodiode.

By providing a P+ layer (emitter) for the light incident section, the sensor electrode that covers the entire light receiving surface of the photodiode can be eliminated, greatly improving the light sensitivity. This P+ layer was also a proposal to reduce the dark current and image lag which became the basis of the pinned photodiode

<https://www.shmj.or.jp/english/pdf/dis/exhibi1005E.pdf>

Double Junction Dynamic Photo Transistor (PPD) invented in 1975 by Hagiwara at Sony.

Triple Junction Dynamic Photo Thyristor (HAD) invented in 1975 by Hagiwara at Sony.

See Japanese Patent Application JPA 1975-127646, 1975-127647 and 1975-134985

Hagiwara invented Pinned Photodiode (PPD).

Japanese Patent Applications, JPA1975-127646, JPA1975-127647 and JPA 1975-134985, filed by Yoshiaki Hagiwara at Sony in 1975, show that Hagiwara invented Buried Photodiode (BPD) with the Pinned Surface Hole Accumulation, Pinned Photodiode (PPD) and Hole Accumulation Diode (HAD). It is also evident that Hagiwara invented Global Shutter Scheme of the three level clocking with MOS Capacitor Buffer Memory, clearly shown in JPA 1975-127646 and JPA 1975-127647. It is also evident that Hagiwara et al invented the Electrical Shutter Clocking Scheme by controlling punch-thru action of the in-pixel overflow drain (OFD) voltage as evidenced in JPA 1977-136885.

(1) Bucket Brigade Device (BBD)

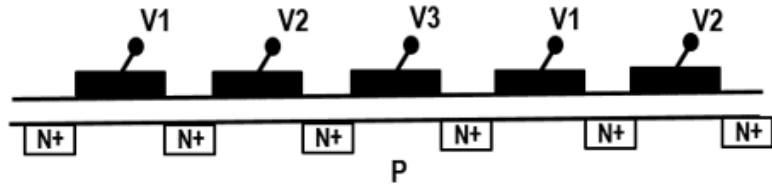

(2) Surface Channel CCD

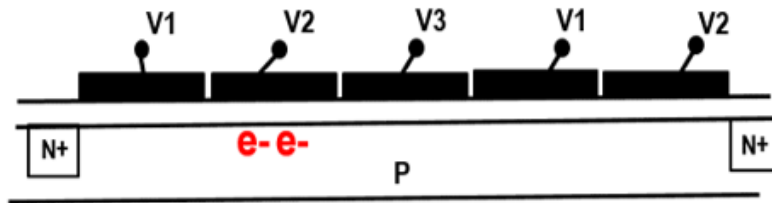

(3) Buried Channel CCD

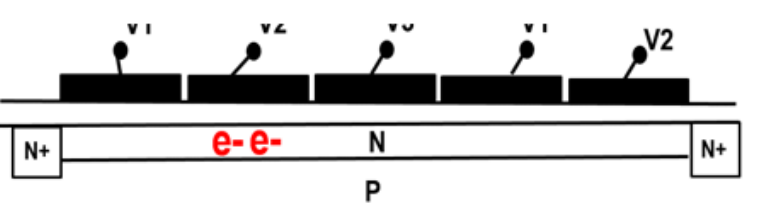

(3) Pinned Photodiode reported at SSDM 1978

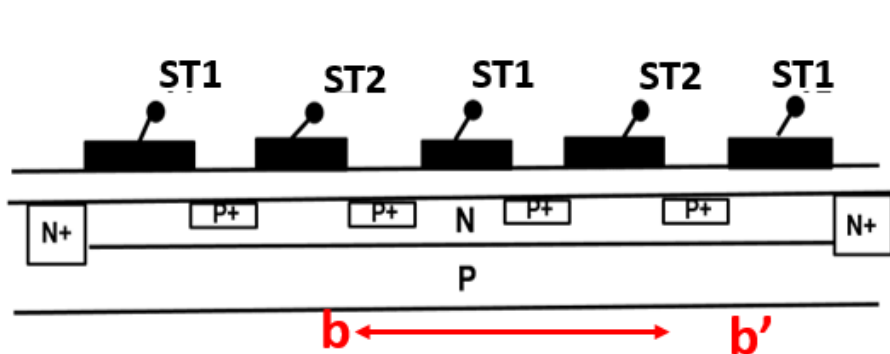

Narrow Charge Transfer Gate (CTG) and Pinned Photodiode (PPD) with the adjacent P+ channel stops

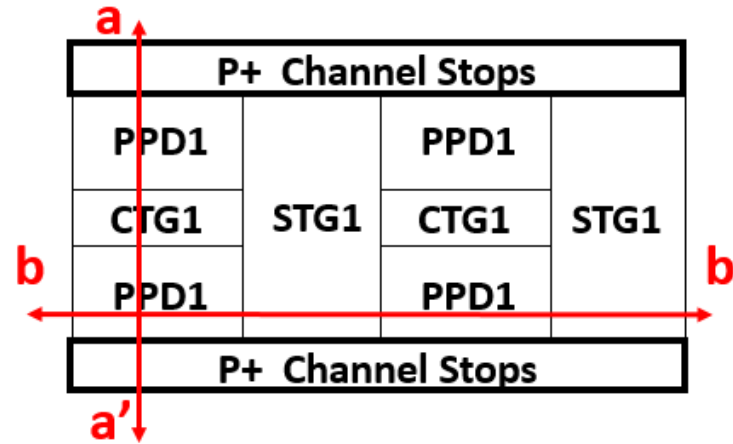

The first Pinned Photodiode(PPD) developed in 1978 by Hagiwara and reported at SSDM1978 in Tokyo.

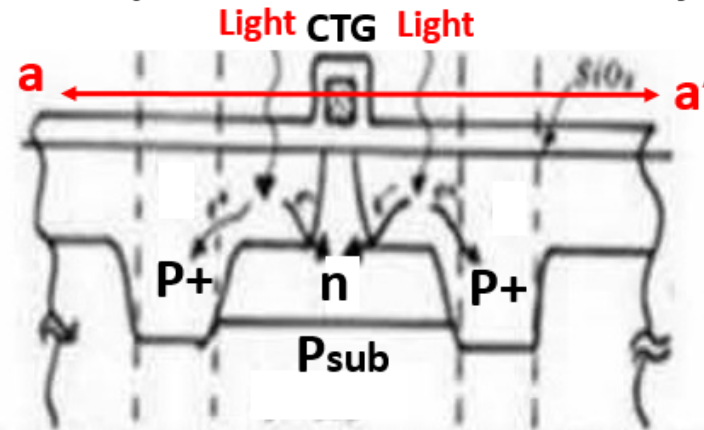

Hagiwara invented Pinned Photodiode (PPD).

Japanese Patent Applications, JPA1975-127646, JPA1975-127647 and JPA 1975-134985, filed by Yoshiaki Hagiwara at Sony in 1975, show that Hagiwara invented Buried Photodiode (BPD) with the Pinned Surface Hole Accumulation, Pinned Photodiode (PPD) and Hole Accumulation Diode (HAD). It is also evident that Hagiwara invented Global Shutter Scheme of the three level clocking with MOS Capacitor Buffer Memory, clearly shown in JPA 1975-127646 and JPA 1975-127647. It is also evident that Hagiwara et al invented the Electrical Shutter Clocking Scheme by controlling punch-thru action of the in-pixel overflow drain (OFD) voltage as evidenced in JPA 1977-136885.

The most important idea of the P+NP Double Junction Buried Pinned Photodiode proposed by Hagiwara in the 1975-134985 Japanese Patent Application is the virtual complete charge transfer operation with no image lag which does not need the conventional double polysilicon overlapping CCD process with very poor productivity.

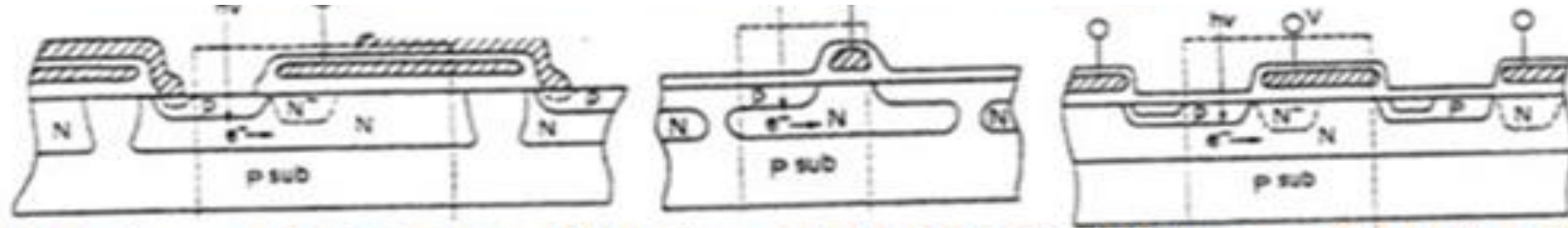

(1) Hagiwara 1975 P+NP PPD JPA 1975-134985 (2) Hagiwara 1978 P+NP PPD SSDM1978 paper (3) Henecek 1979 P+NP PPD

See the Original 1978 Publication of the Pinned Photodiode Sensor

Y. Daimon-Hagiwara, M. Abe, and C. Okada, "A 380Hx488V CCD imager with narrow channel transfer gates," Proceedings of the 10th Conference on Solid State Devices, Tokyo, 1978; Japanese Journal of Applied Physics, vol. 18, supplement 18-1, pp. 335-340, 1979

Light CTG Light

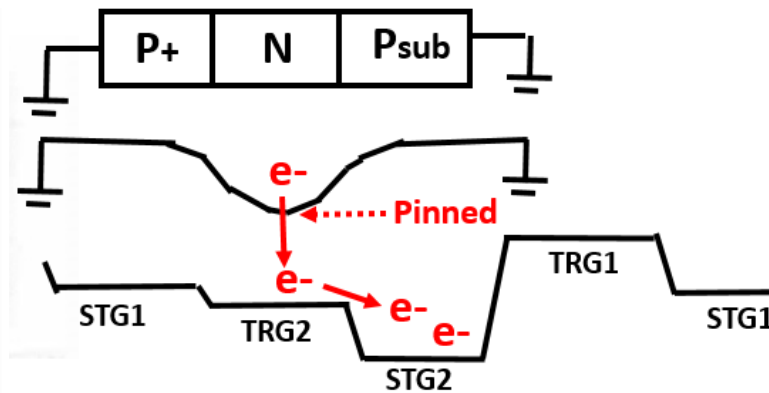
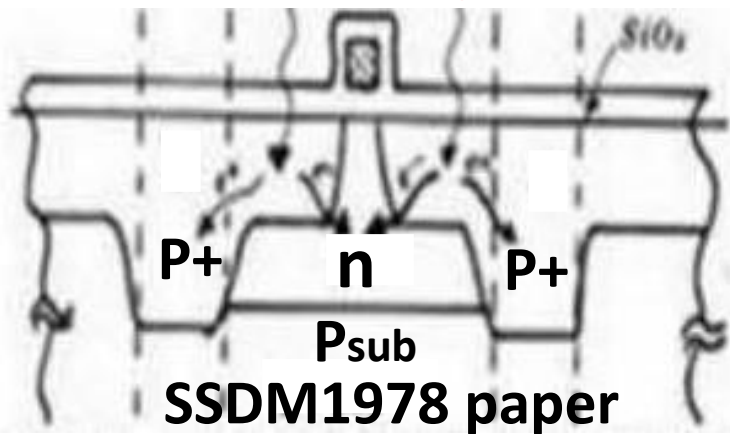

Note that the vertical CCD potential levels of the charge storage gate STG and the charge transfer gate TRG are always both deeper than the Pinned P+NPsub SiO2 exposed light collecting Buried N region.

Hagiwara invented Pinned Photodiode (PPD).

Japanese Patent Applications, JPA1975-127646, JPA1975-127647 and JPA 1975-134985, filed by Yoshiaki Hagiwara at Sony in 1975, show that Hagiwara invented Buried Photodiode (BPD) with the Pinned Surface Hole Accumulation, Pinned Photodiode (PPD) and Hole Accumulation Diode (HAD). It is also evident that Hagiwara invented Global Shutter Scheme of the three level clocking with MOS Capacitor Buffer Memory, clearly shown in JPA 1975-127646 and JPA 1975-127647. It is also evident that Hagiwara et al invented the Electrical Shutter Clocking Scheme by controlling punch-thru action of the in-pixel overflow drain (OFD) voltage as evidenced in JPA 1977-136885.

The most important idea of the P+NP Double Junction Buried Pinned Photodiode proposed by Hagiwara in the 1975-134985 Japanese Patent Application is the virtual complete charge transfer operation with no image lag which does not need the conventional double polysilicon overlapping CCD process with very poor productivity.

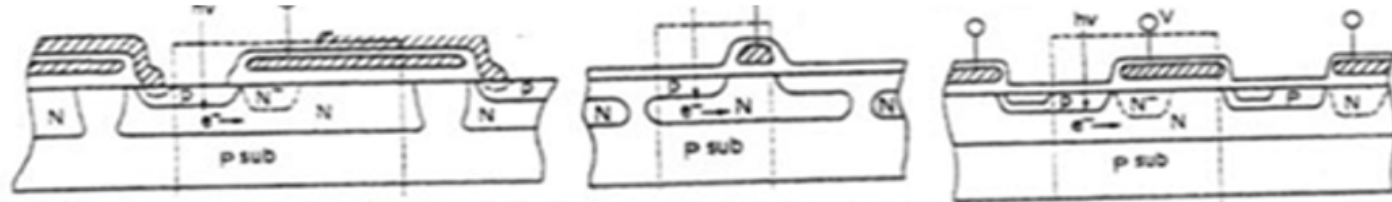

(1) Hagiwara 1975 P+NP PPD JPA 1975-134985 (2) Hagiwara 1978 P+NP PPD SSDM1978 paper (3) Henecek 1979 P+NP PPD

This may have a problem ??
The reason is explained below.

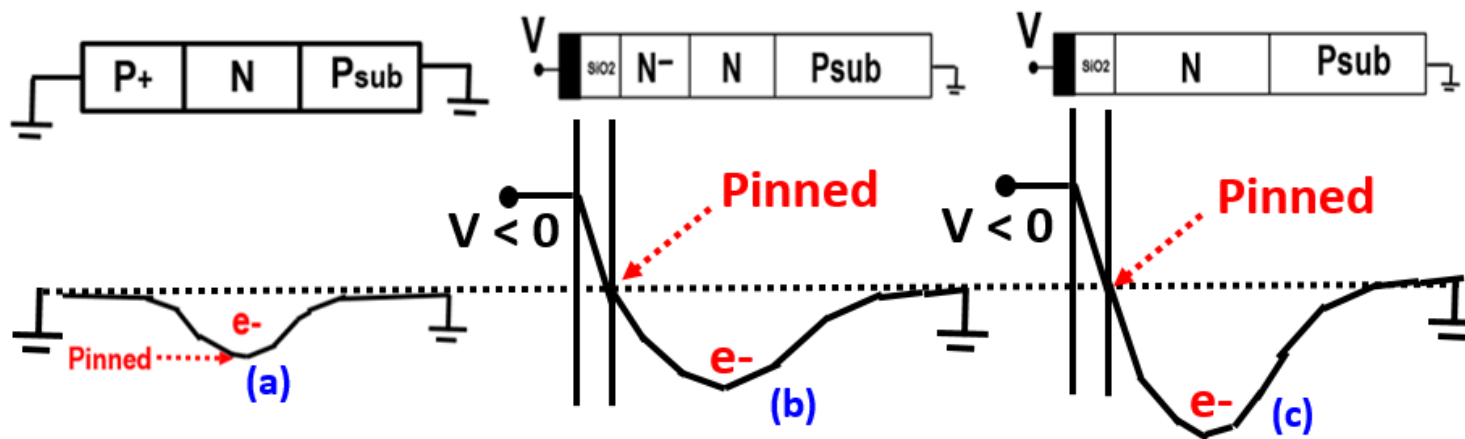

Even though the gate voltage $V < 0$ is set at a strong negative value, the silicon surface potential will be in the hole accumulation condition with the Pinned grounded voltage level. The buried channel CCD potentials (b) and (c) are always deeper than the Pinned Empty Potential (a) of the Pinned Photodiode.

Hagiwara invented Pinned Photodiode (PPD).

Japanese Patent Applications, JPA1975-127646, JPA1975-127647 and JPA 1975-134985, filed by Yoshiaki Hagiwara at Sony in 1975, show that Hagiwara invented Buried Photodiode (BPD) with the Pinned Surface Hole Accumulation, Pinned Photodiode (PPD) and Hole Accumulation Diode (HAD). It is also evident that Hagiwara invented Global Shutter Scheme of the three level clocking with MOS Capacitor Buffer Memory, clearly shown in JPA 1975-127646 and JPA 1975-127647. It is also evident that Hagiwara et al invented the Electrical Shutter Clocking Scheme by controlling punch-thru action of the in-pixel overflow drain (OFD) voltage as evidenced in JPA 1977-136885.

Hagiwara_invented_PPD_and_Virtual_Charge_Transfer_in_1975

Hagiwara in 1975 proposed the PPD Charge Transfer which is later called as Virtual Phase Charge Transfer.

Hagiwara in 1975 proposed also the NEC Buried Photodiode, the KODAK PPD and the Sony HAD.

Study Japanese Patent 1975-127646, 1975-127647 and 1975-134985 for the details.

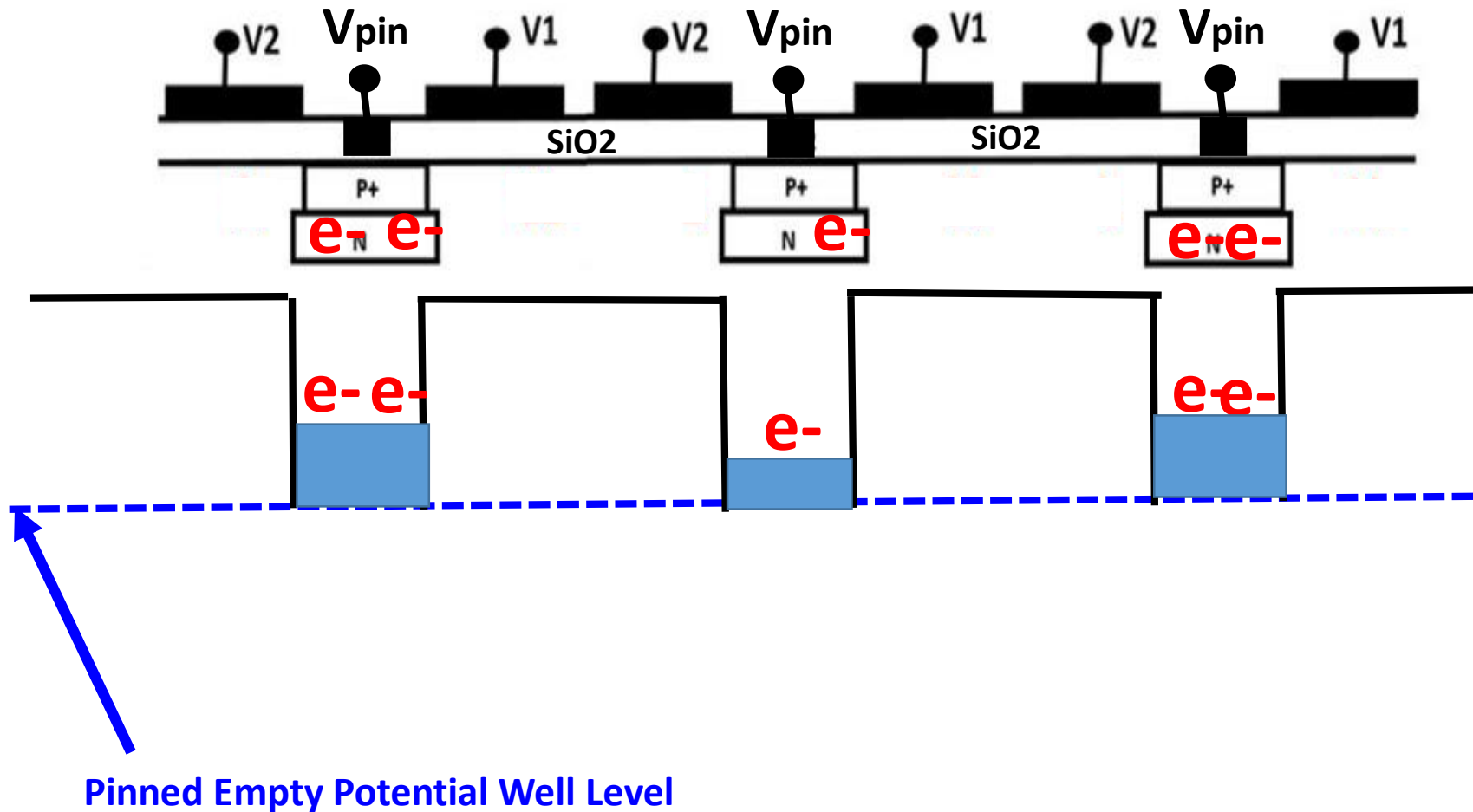

Hagiwara invented Pinned Photodiode (PPD).

Japanese Patent Applications, JPA1975-127646, JPA1975-127647 and JPA 1975-134985, filed by Yoshiaki Hagiwara at Sony in 1975, show that Hagiwara invented Buried Photodiode (BPD) with the Pinned Surface Hole Accumulation, Pinned Photodiode (PPD) and Hole Accumulation Diode (HAD). It is also evident that Hagiwara invented Global Shutter Scheme of the three level clocking with MOS Capacitor Buffer Memory, clearly shown in JPA 1975-127646 and JPA 1975-127647. It is also evident that Hagiwara et al invented the Electrical Shutter Clocking Scheme by controlling punch-thru action of the in-pixel overflow drain (OFD) voltage as evidenced in JPA 1977-136885.

Hagiwara_invented_PPD_and_Virtual_Charge_Transfer_in_1975

Hagiwara in 1975 proposed the PPD Charge Transfer which is later called as Virtual Phase Charge Transfer.

Hagiwara in 1975 proposed also the NEC Buried Photodiode, the KODAK PPD and the Sony HAD.

Study Japanese Patent 1975-127646, 1975-127647 and 1975-134985 for the details.

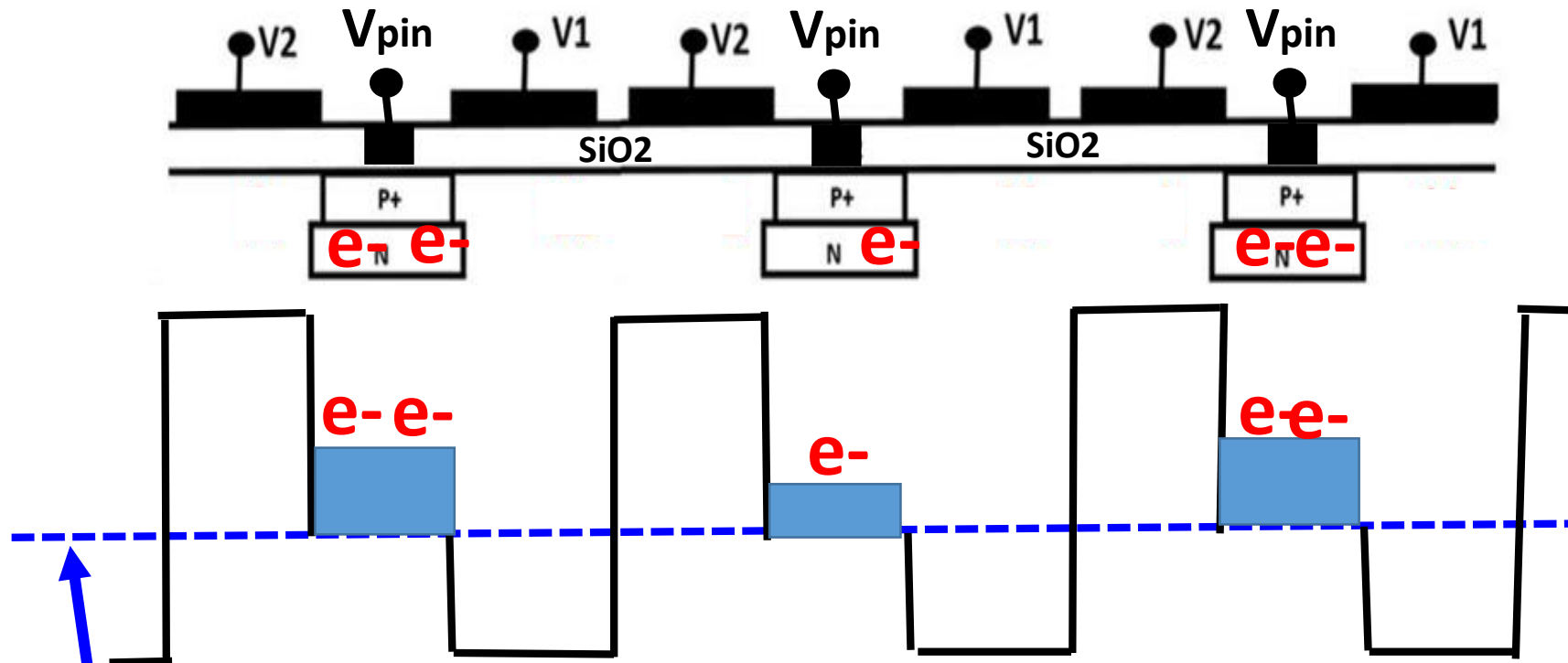

Pinned Empty Potential Well Level

Hagiwara invented Pinned Photodiode (PPD).

Japanese Patent Applications, JPA1975-127646, JPA1975-127647 and JPA 1975-134985, filed by Yoshiaki Hagiwara at Sony in 1975, show that Hagiwara invented Buried Photodiode (BPD) with the Pinned Surface Hole Accumulation, Pinned Photodiode (PPD) and Hole Accumulation Diode (HAD). It is also evident that Hagiwara invented Global Shutter Scheme of the three level clocking with MOS Capacitor Buffer Memory, clearly shown in JPA 1975-127646 and JPA 1975-127647. It is also evident that Hagiwara et al invented the Electrical Shutter Clocking Scheme by controlling punch-thru action of the in-pixel overflow drain (OFD) voltage as evidenced in JPA 1977-136885.

Hagiwara_invented_PPD_and_Virtual_Charge_Transfer_in_1975

Hagiwara in 1975 proposed the PPD Charge Transfer which is later called as Virtual Phase Charge Transfer.

Hagiwara in 1975 proposed also the NEC Buried Photodiode, the KODAK PPD and the Sony HAD.

Study Japanese Patent 1975-127646, 1975-127647 and 1975-134985 for the details.

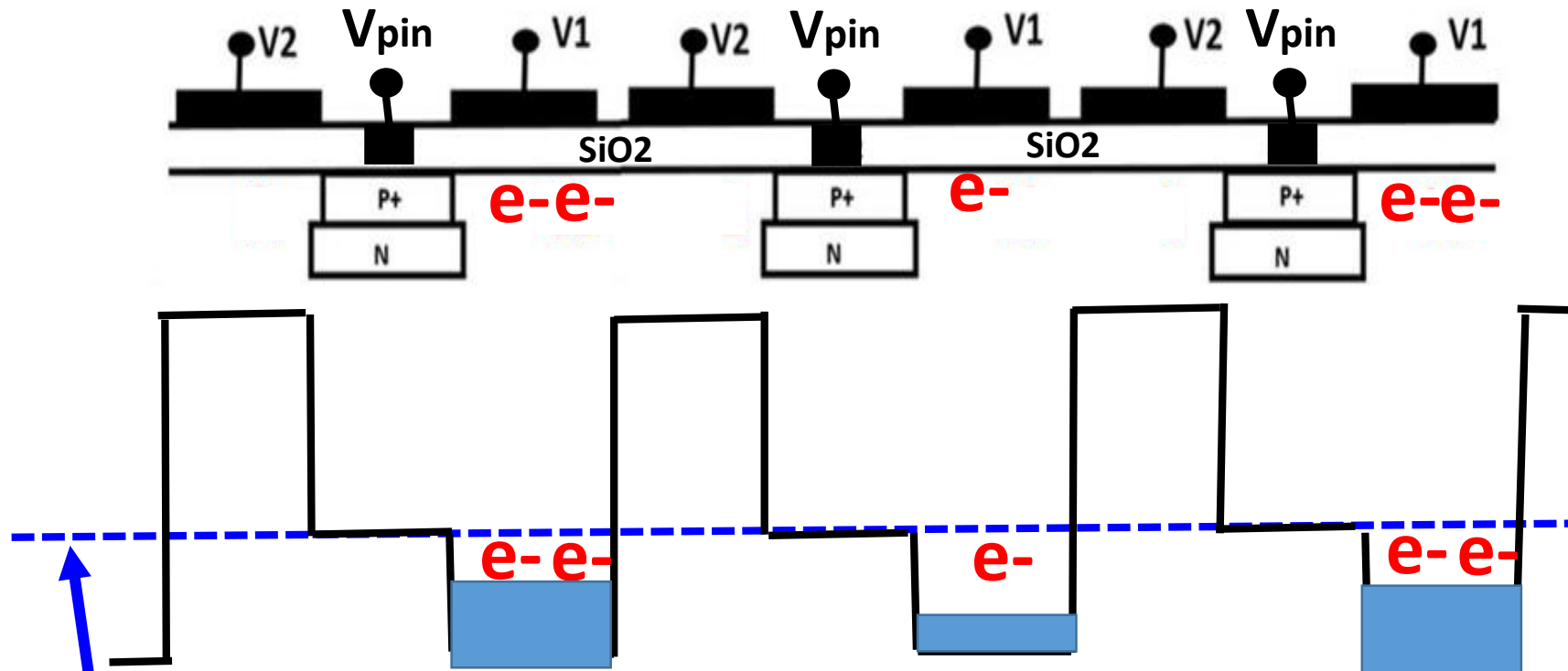

Pinned Empty Potential Well Level

Hagiwara invented Pinned Photodiode (PPD).

Japanese Patent Applications, JPA1975-127646, JPA1975-127647 and JPA 1975-134985, filed by Yoshiaki Hagiwara at Sony in 1975, show that Hagiwara invented Buried Photodiode (BPD) with the Pinned Surface Hole Accumulation, Pinned Photodiode (PPD) and Hole Accumulation Diode (HAD). It is also evident that Hagiwara invented Global Shutter Scheme of the three level clocking with MOS Capacitor Buffer Memory, clearly shown in JPA 1975-127646 and JPA 1975-127647. It is also evident that Hagiwara et al invented the Electrical Shutter Clocking Scheme by controlling punch-thru action of the in-pixel overflow drain (OFD) voltage as evidenced in JPA 1977-136885.

Hagiwara_invented_PPD_and_Virtual_Charge_Transfer_in_1975

Hagiwara in 1975 proposed the PPD Charge Transfer which is later called as Virtual Phase Charge Transfer.

Hagiwara in 1975 proposed also the NEC Buried Photodiode, the KODAK PPD and the Sony HAD.

Study Japanese Patent 1975-127646, 1975-127647 and 1975-134985 for the details.

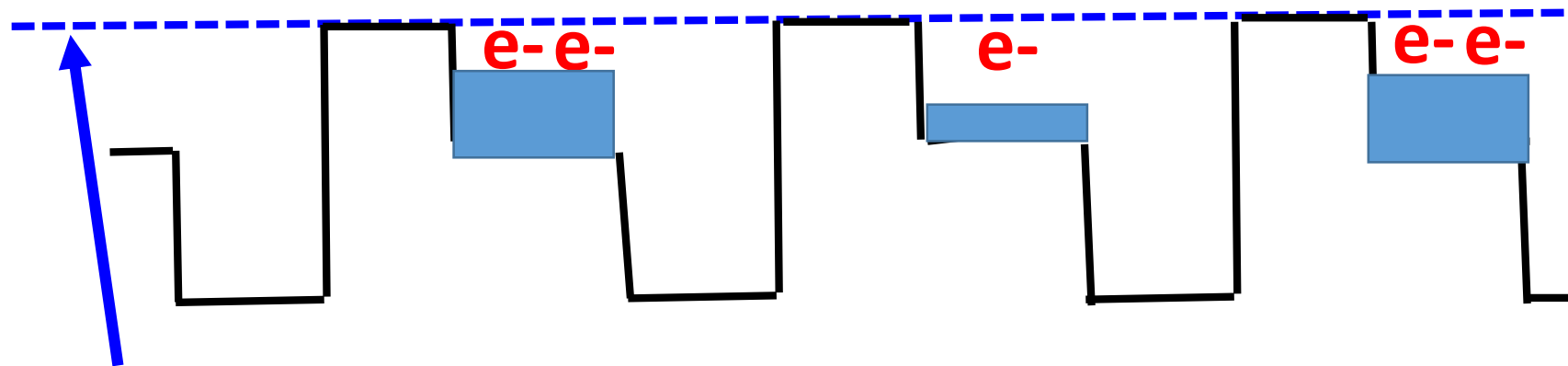
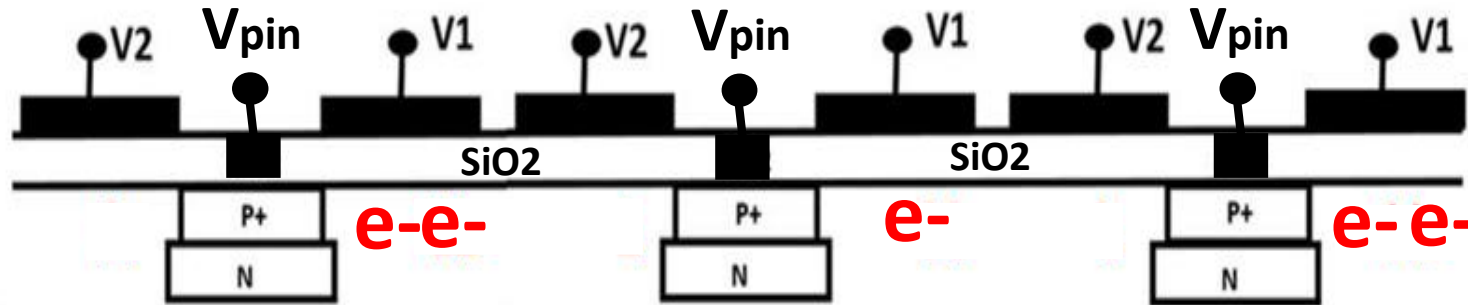

Pinned Empty Potential Well Level

Hagiwara invented Pinned Photodiode (PPD).

Japanese Patent Applications, JPA1975-127646, JPA1975-127647 and JPA 1975-134985, filed by Yoshiaki Hagiwara at Sony in 1975, show that Hagiwara invented Buried Photodiode (BPD) with the Pinned Surface Hole Accumulation, Pinned Photodiode (PPD) and Hole Accumulation Diode (HAD). It is also evident that Hagiwara invented Global Shutter Scheme of the three level clocking with MOS Capacitor Buffer Memory, clearly shown in JPA 1975-127646 and JPA 1975-127647. It is also evident that Hagiwara et al invented the Electrical Shutter Clocking Scheme by controlling punch-thru action of the in-pixel overflow drain (OFD) voltage as evidenced in JPA 1977-136885.

Hagiwara_invented_PPD_and_Virtual_Charge_Transfer_in_1975

Hagiwara in 1975 proposed the PPD Charge Transfer which is later called as Virtual Phase Charge Transfer.

Hagiwara in 1975 proposed also the NEC Buried Photodiode, the KODAK PPD and the Sony HAD.

Study Japanese Patent 1975-127646, 1975-127647 and 1975-134985 for the details.

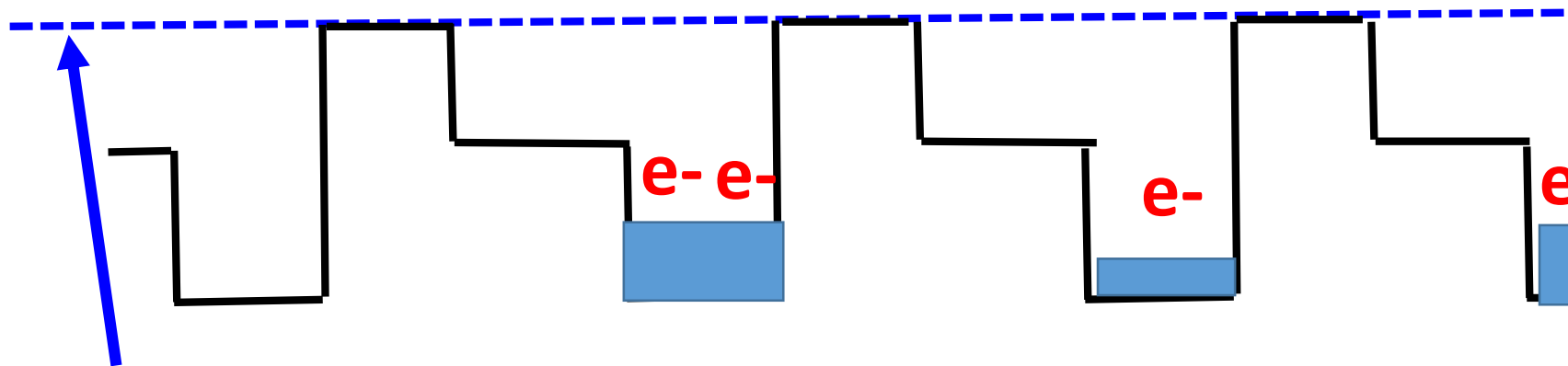
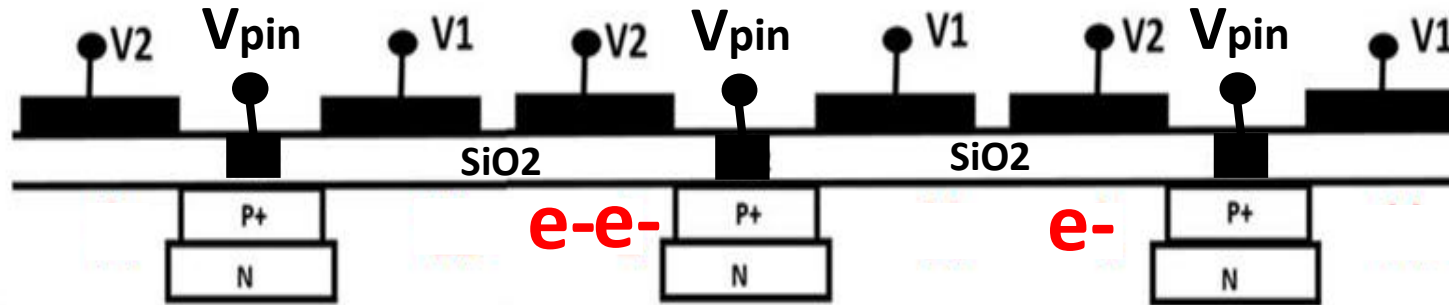

Pinned Empty Potential Well Level

Hagiwara invented Pinned Photodiode (PPD).

Japanese Patent Applications, JPA1975-127646, JPA1975-127647 and JPA 1975-134985, filed by Yoshiaki Hagiwara at Sony in 1975, show that Hagiwara invented Buried Photodiode (BPD) with the Pinned Surface Hole Accumulation, Pinned Photodiode (PPD) and Hole Accumulation Diode (HAD). It is also evident that Hagiwara invented Global Shutter Scheme of the three level clocking with MOS Capacitor Buffer Memory, clearly shown in JPA 1975-127646 and JPA 1975-127647. It is also evident that Hagiwara et al invented the Electrical Shutter Clocking Scheme by controlling punch-thru action of the in-pixel overflow drain (OFD) voltage as evidenced in JPA 1977-136885.

Hagiwara_invented_PPD_and_Virtual_Charge_Transfer_in_1975

Hagiwara in 1975 proposed the PPD Charge Transfer which is later called as Virtual Phase Charge Transfer.

Hagiwara in 1975 proposed also the NEC Buried Photodiode, the KODAK PPD and the Sony HAD.

Study Japanese Patent 1975-127646, 1975-127647 and 1975-134985 for the details.

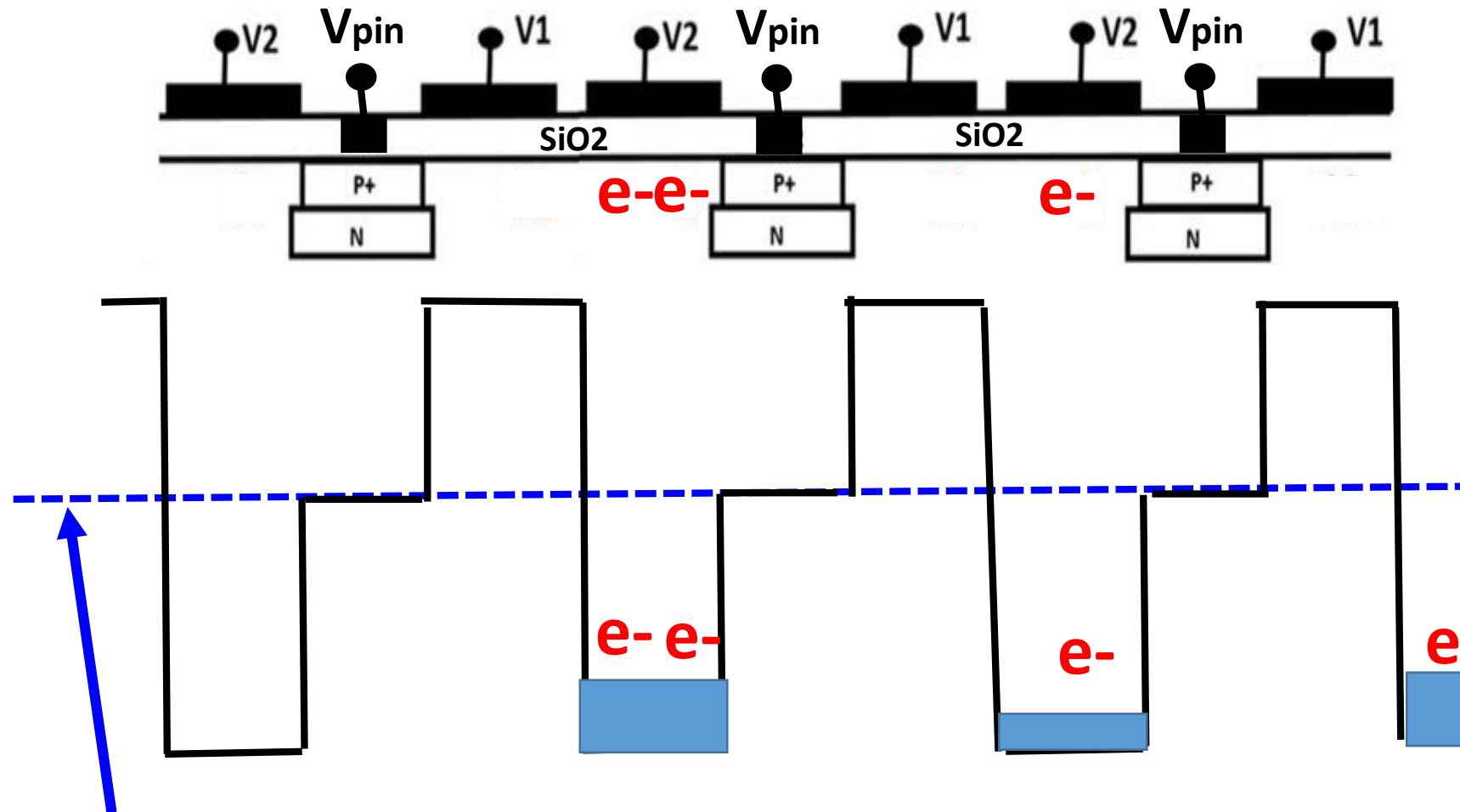

Pinned Empty Potential Well Level

Hagiwara invented Pinned Photodiode (PPD).

Japanese Patent Applications, JPA1975-127646, JPA1975-127647 and JPA 1975-134985, filed by Yoshiaki Hagiwara at Sony in 1975, show that Hagiwara invented Buried Photodiode (BPD) with the Pinned Surface Hole Accumulation, Pinned Photodiode (PPD) and Hole Accumulation Diode (HAD). It is also evident that Hagiwara invented Global Shutter Scheme of the three level clocking with MOS Capacitor Buffer Memory, clearly shown in JPA 1975-127646 and JPA 1975-127647. It is also evident that Hagiwara et al invented the Electrical Shutter Clocking Scheme by controlling punch-thru action of the in-pixel overflow drain (OFD) voltage as evidenced in JPA 1977-136885.

Hagiwara_invented_PPD_and_Virtual_Charge_Transfer_in_1975

Hagiwara in 1975 proposed the PPD Charge Transfer which is later called as Virtual Phase Charge Transfer.

Hagiwara in 1975 proposed also the NEC Buried Photodiode, the KODAK PPD and the Sony HAD.

Study Japanese Patent 1975-127646, 1975-127647 and 1975-134985 for the details.

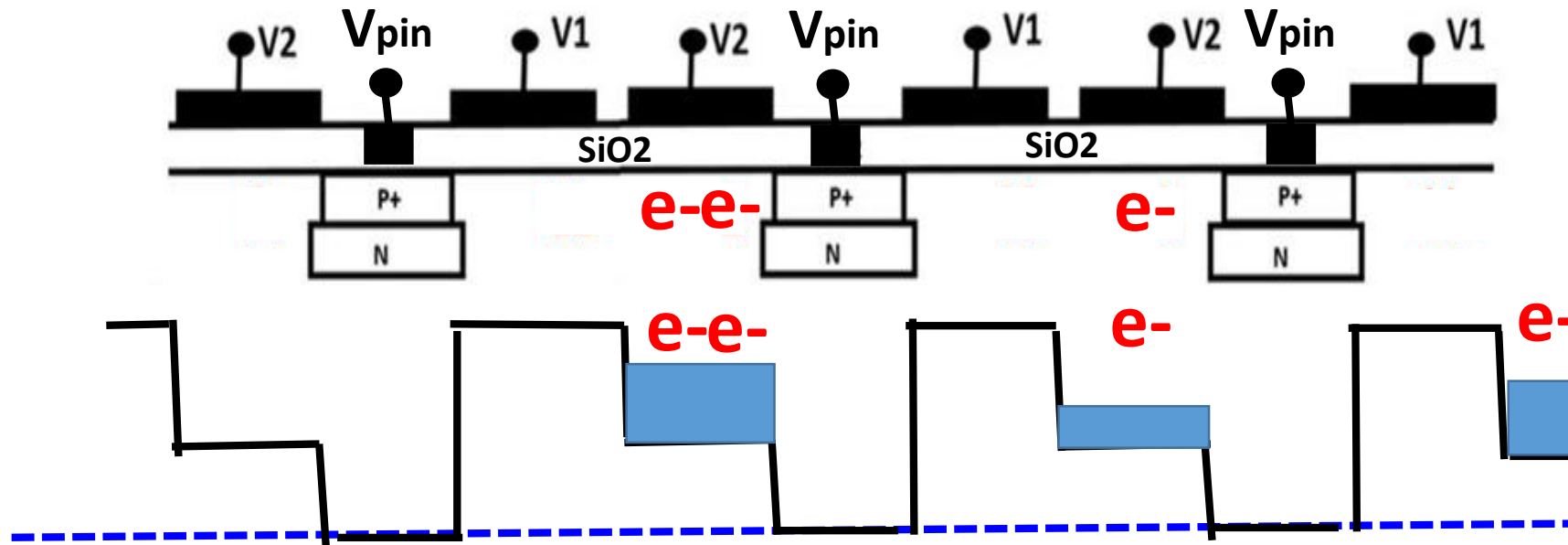

Pinned Empty Potential Well Level

Hagiwara invented Pinned Photodiode (PPD).

Japanese Patent Applications, JPA1975-127646, JPA1975-127647 and JPA 1975-134985, filed by Yoshiaki Hagiwara at Sony in 1975, show that Hagiwara invented Buried Photodiode (BPD) with the Pinned Surface Hole Accumulation, Pinned Photodiode (PPD) and Hole Accumulation Diode (HAD). It is also evident that Hagiwara invented Global Shutter Scheme of the three level clocking with MOS Capacitor Buffer Memory, clearly shown in JPA 1975-127646 and JPA 1975-127647. It is also evident that Hagiwara et al invented the Electrical Shutter Clocking Scheme by controlling punch-thru action of the in-pixel overflow drain (OFD) voltage as evidenced in JPA 1977-136885.

Hagiwara_invented_PPD_and_Virtual_Charge_Transfer_in_1975

Hagiwara in 1975 proposed the PPD Charge Transfer which is later called as Virtual Phase Charge Transfer.

Hagiwara in 1975 proposed also the NEC Buried Photodiode, the KODAK PPD and the Sony HAD.

Study Japanese Patent 1975-127646, 1975-127647 and 1975-134985 for the details.

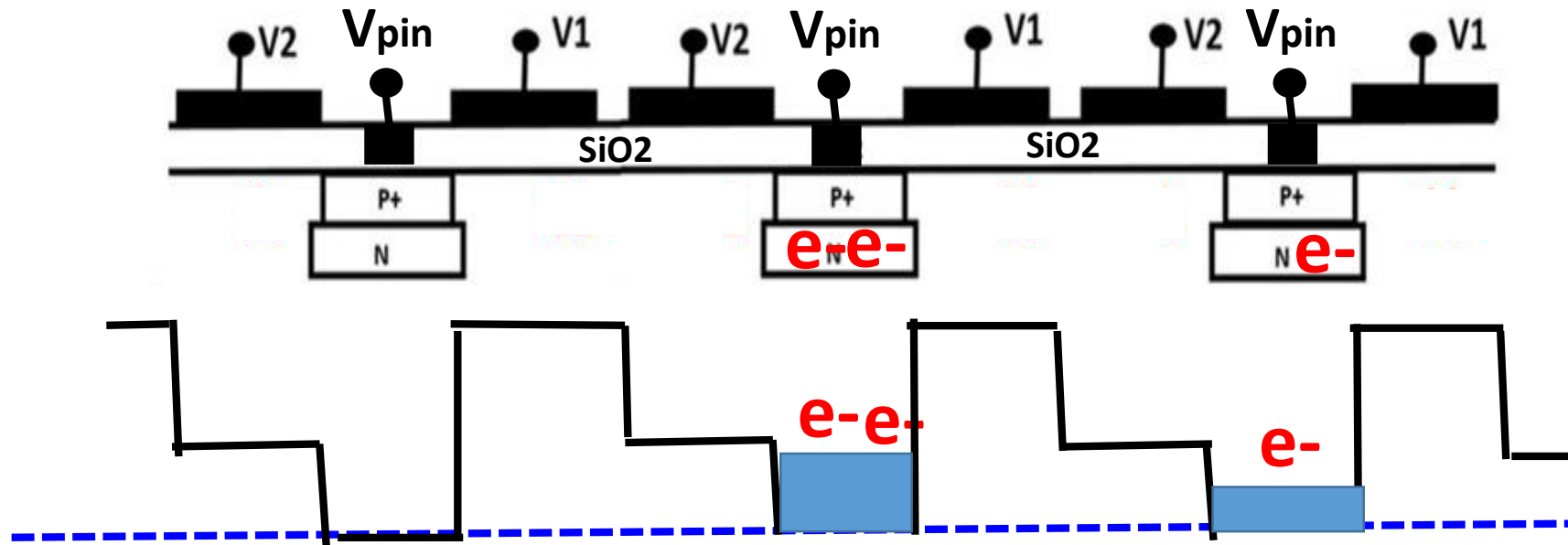

Pinned Empty Potential Well Level

Hagiwara invented Pinned Photodiode (PPD).

Japanese Patent Applications, JPA1975-127646, JPA1975-127647 and JPA 1975-134985, filed by Yoshiaki Hagiwara at Sony in 1975, show that Hagiwara invented Buried Photodiode (BPD) with the Pinned Surface Hole Accumulation, Pinned Photodiode (PPD) and Hole Accumulation Diode (HAD). It is also evident that Hagiwara invented Global Shutter Scheme of the three level clocking with MOS Capacitor Buffer Memory, clearly shown in JPA 1975-127646 and JPA 1975-127647. It is also evident that Hagiwara et al invented the Electrical Shutter Clocking Scheme by controlling punch-thru action of the in-pixel overflow drain (OFD) voltage as evidenced in JPA 1977-136885.

Hagiwara_invented_PPD_and_Virtual_Charge_Transfer_in_1975

Hagiwara in 1975 proposed the PPD Charge Transfer which is later called as Virtual Phase Charge Transfer.

Hagiwara in 1975 proposed also the NEC Buried Photodiode, the KODAK PPD and the Sony HAD.

Study Japanese Patent 1975-127646, 1975-127647 and 1975-134985 for the details.

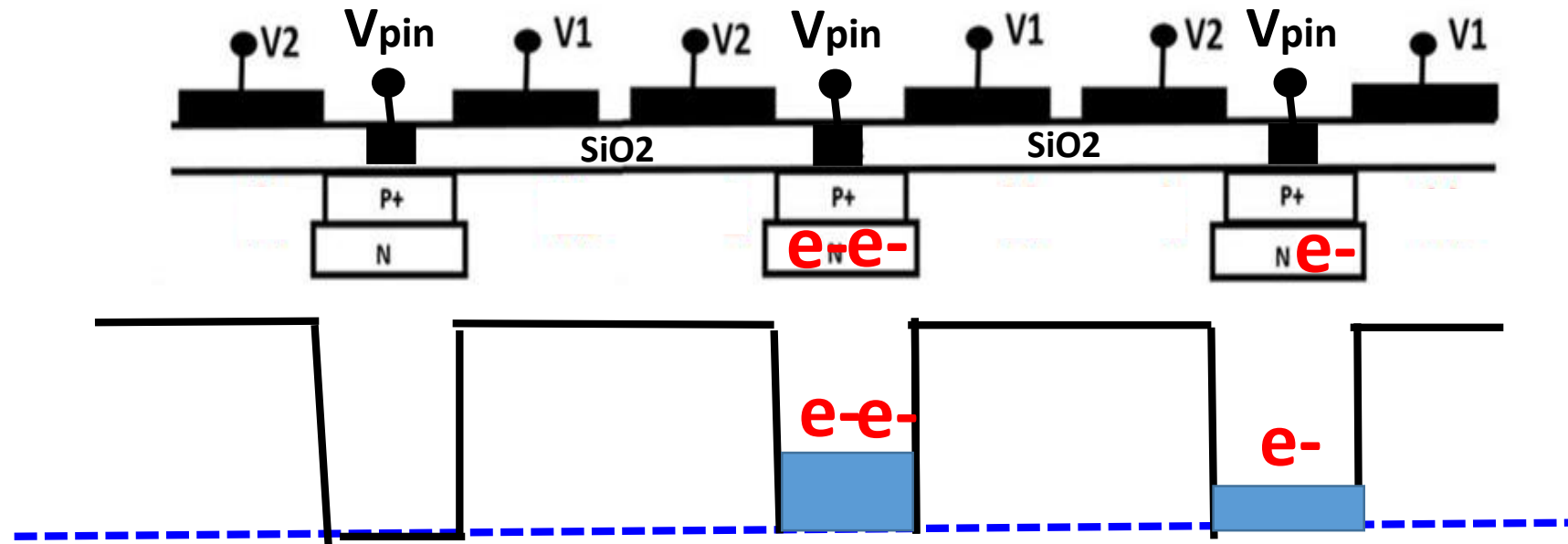

Pinned Empty Potential Well Level

Hagiwara invented Pinned Photodiode (PPD).

Japanese Patent Applications, JPA1975-127646, JPA1975-127647 and JPA 1975-134985, filed by Yoshiaki Hagiwara at Sony in 1975, show that Hagiwara invented Buried Photodiode (BPD) with the Pinned Surface Hole Accumulation, Pinned Photodiode (PPD) and Hole Accumulation Diode (HAD). It is also evident that Hagiwara invented Global Shutter Scheme of the three level clocking with MOS Capacitor Buffer Memory, clearly shown in JPA 1975-127646 and JPA 1975-127647. It is also evident that Hagiwara et al invented the Electrical Shutter Clocking Scheme by controlling punch-thru action of the in-pixel overflow drain (OFD) voltage as evidenced in JPA 1977-136885.

Back Light Illumination
Sony CMOS Image Sensor (2020)

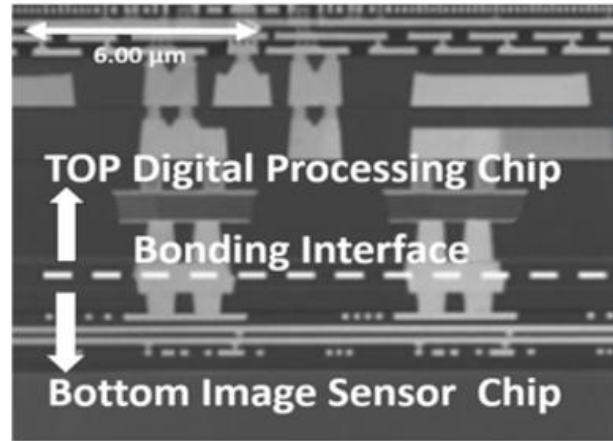

P+PNPP+ Junction Buried Pinned Photodiode
for Back Light (JAP 1975-127647)

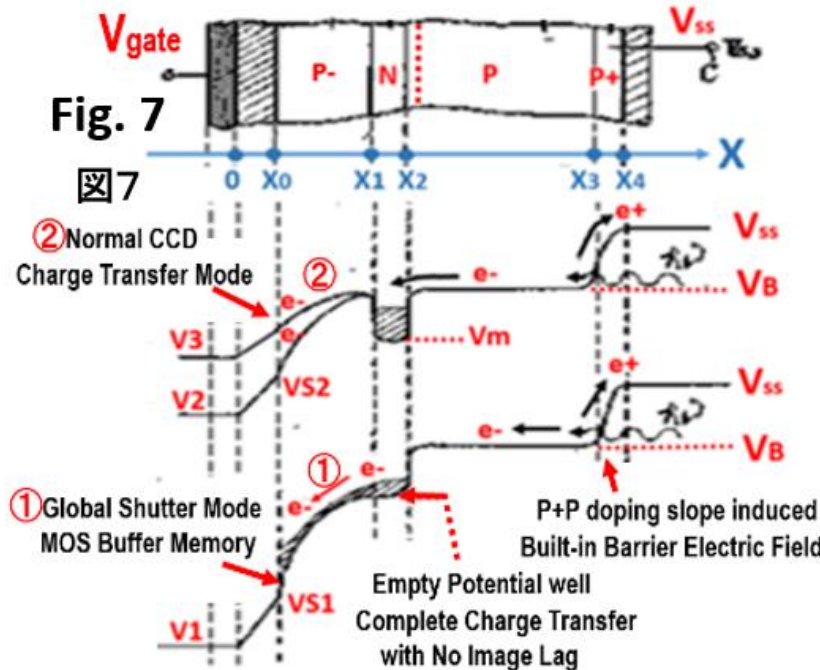

Multi-chips three dimensional LSI chip

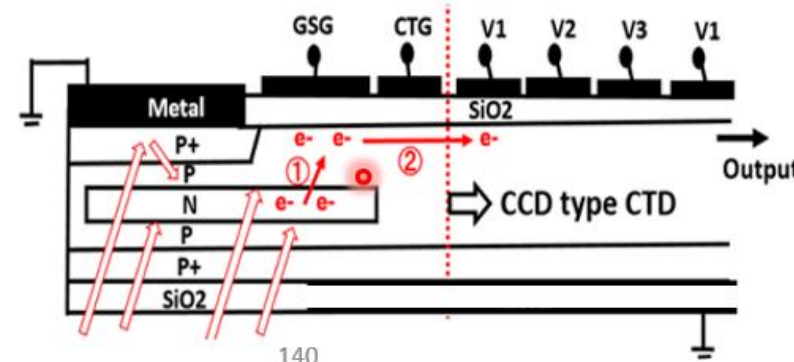
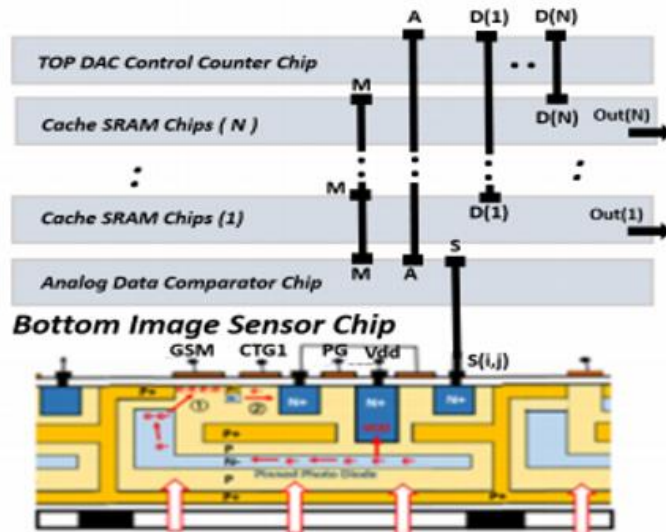

Hagiwara invented Pinned Photodiode (PPD).

Japanese Patent Applications, JPA1975-127646, JPA1975-127647 and JPA 1975-134985, filed by Yoshiaki Hagiwara at Sony in 1975, show that Hagiwara invented Buried Photodiode (BPD) with the Pinned Surface Hole Accumulation, Pinned Photodiode (PPD) and Hole Accumulation Diode (HAD). It is also evident that Hagiwara invented Global Shutter Scheme of the three level clocking with MOS Capacitor Buffer Memory, clearly shown in JPA 1975-127646 and JPA 1975-127647. It is also evident that Hagiwara et al invented the Electrical Shutter Clocking Scheme by controlling punch-thru action of the in-pixel overflow drain (OFD) voltage as evidenced in JPA 1977-136885.

Sun Light Spectrum

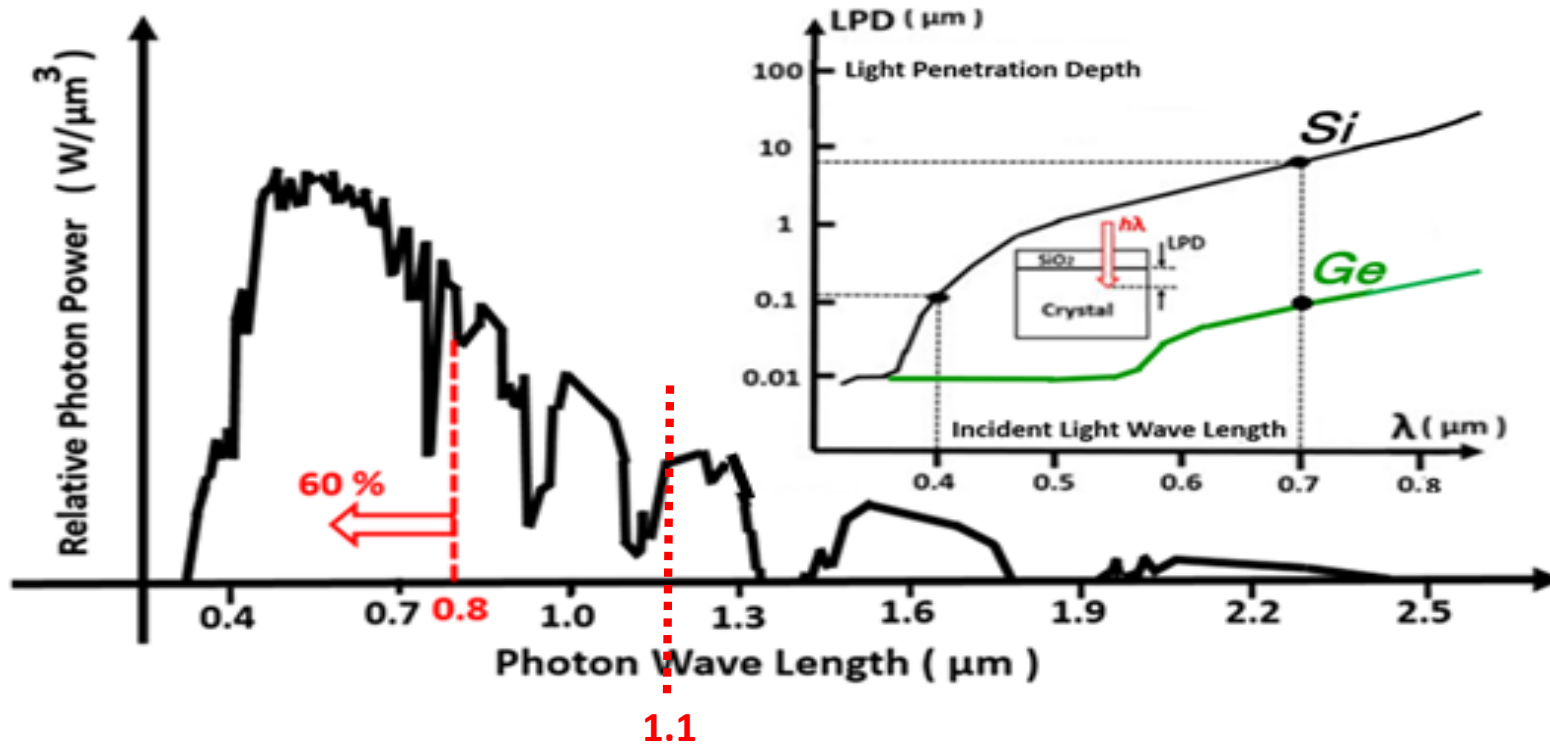

$$E = \hbar \omega = h f = h c / \lambda$$

$$E \text{ (eV)} = 1.24 / \lambda \text{ (\mu m)}$$

For Silicon, $E_g = 1.10 \text{ eV}$ and $\lambda = 1.12 \mu m$

The light energy of the wave length more than $\lambda = 1.12 \mu m$ can not be converted to electrical energy in the silicon crystal.

Hagiwara invented Pinned Photodiode (PPD).

Japanese Patent Applications, JPA1975-127646, JPA1975-127647 and JPA 1975-134985, filed by Yoshiaki Hagiwara at Sony in 1975, show that Hagiwara invented Buried Photodiode (BPD) with the Pinned Surface Hole Accumulation, Pinned Photodiode (PPD) and Hole Accumulation Diode (HAD). It is also evident that Hagiwara invented Global Shutter Scheme of the three level clocking with MOS Capacitor Buffer Memory, clearly shown in JPA 1975-127646 and JPA 1975-127647. It is also evident that Hagiwara et al invented the Electrical Shutter Clocking Scheme by controlling punch-thru action of the in-pixel overflow drain (OFD) voltage as evidenced in JPA 1977-136885.

Conventional N+P Single junction Type Solar Cell

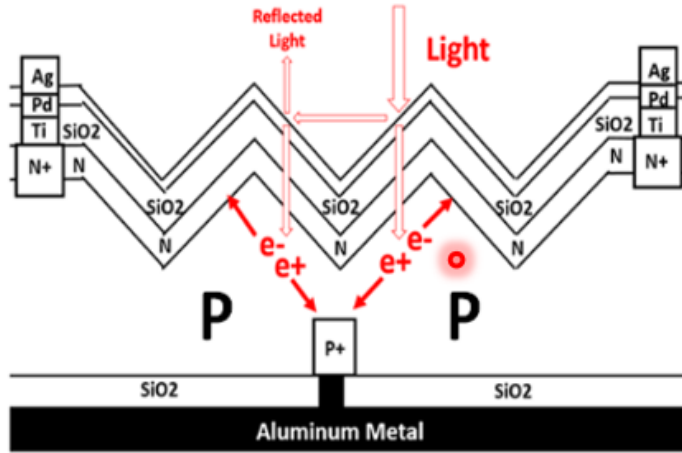

Poor Blue Light Sensitivity Problem

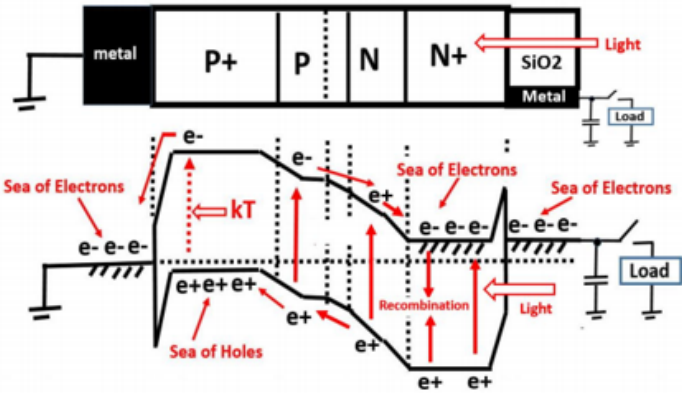

Single Junction N+P type Solar Cell also has a very poor short wave blue light sensitivity.

PNP Double Junction Type Solar Cell proposed by Hagiwara in 2020

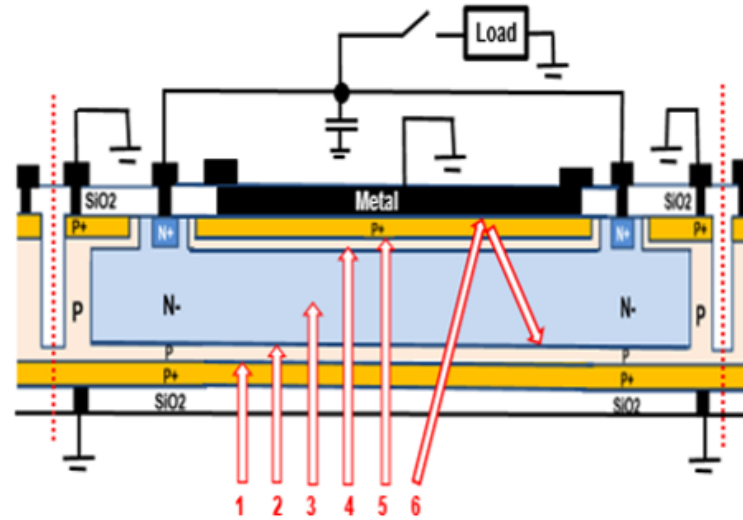

Completely depleted Buried N region In the PNP Double Junction Type Solar Cell proposed by Hagiwara in 2020

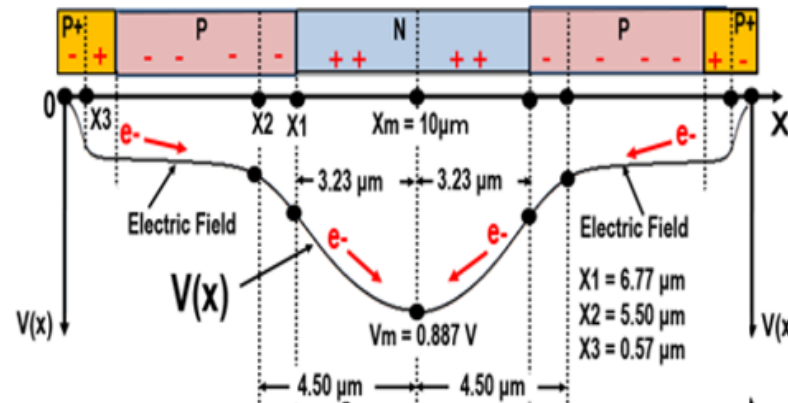

Hagiwara invented Pinned Photodiode (PPD).

Japanese Patent Applications, JPA1975-127646, JPA1975-127647 and JPA 1975-134985, filed by Yoshiaki Hagiwara at Sony in 1975, show that Hagiwara invented Buried Photodiode (BPD) with the Pinned Surface Hole Accumulation, Pinned Photodiode (PPD) and Hole Accumulation Diode (HAD). It is also evident that Hagiwara invented Global Shutter Scheme of the three level clocking with MOS Capacitor Buffer Memory, clearly shown in JPA 1975-127646 and JPA 1975-127647. It is also evident that Hagiwara et al invented the Electrical Shutter Clocking Scheme by controlling punch-thru action of the in-pixel overflow drain (OFD) voltage as evidenced in JPA 1977-136885.

The P+PNPP+ Junction Type Pinned Photodiode Solar Cell with Very High Blue Light Sensitivity

Pinned P+P Surface

Barrier Potential V_B

$$V_B = kT \ln \left(\frac{N_{pp}}{N_p} \right)$$

Reference JPA 2020-131313 by Yoshiaki Hagiwara



The yellow region has the barrier electric field for photo electron and hole pairs separation, contributing to the solar cell quantum efficiency.

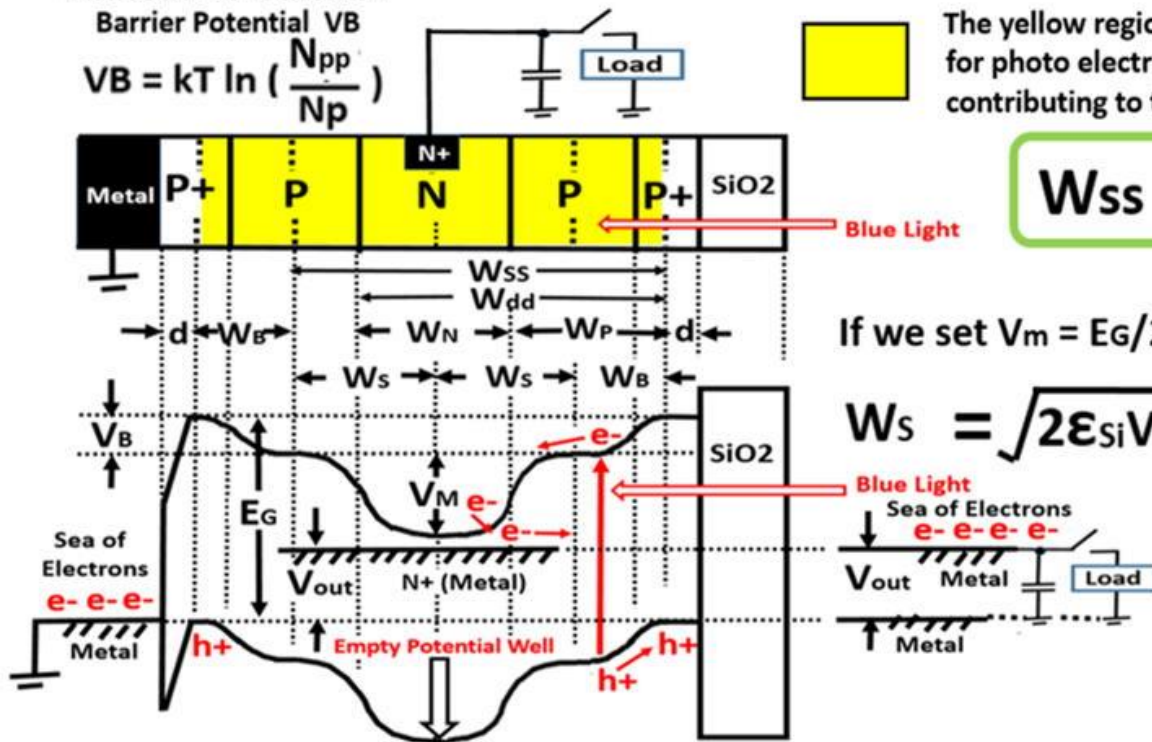

$$W_{SS} = W_B + 2 W_S$$

If we set $V_m = E_G/2$,

$$\frac{1}{N} = \frac{1}{N_d} + \frac{1}{N_p}$$

$$W_S = \sqrt{2\epsilon_{Si} V_M / N} \doteq \sqrt{\epsilon_{Si} E_G / N}$$

The concept of Empty Potential Well was originally proposed in 1975 by Hagiwara in JPA 1975-134985.

The surface P+P Pinned Surface Solar Cell with the surface P+P Gaussian doping slope is very important to create the surface barrier electric field for separating the photo electron and hole pairs generated by the short wave length blue light which cannot penetrate into the silicon crystal more than 0.2 μm in depth.

Hagiwara invented Pinned Photodiode (PPD).

Japanese Patent Applications, JPA1975-127646, JPA1975-127647 and JPA 1975-134985, filed by Yoshiaki Hagiwara at Sony in 1975, show that Hagiwara invented Buried Photodiode (BPD) with the Pinned Surface Hole Accumulation, Pinned Photodiode (PPD) and Hole Accumulation Diode (HAD). It is also evident that Hagiwara invented Global Shutter Scheme of the three level clocking with MOS Capacitor Buffer Memory, clearly shown in JPA 1975-127646 and JPA 1975-127647. It is also evident that Hagiwara et al invented the Electrical Shutter Clocking Scheme by controlling punch-thru action of the in-pixel overflow drain (OFD) voltage as evidenced in JPA 1977-136885.

Difference of Buried Photodiode and Pinned Photodiode

Figure 5 does not have the P+ channel stop nearby.

Buried Photodiode

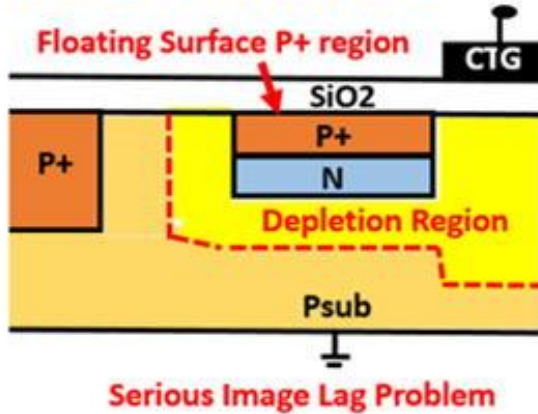

NEC IEDM1982 Paper

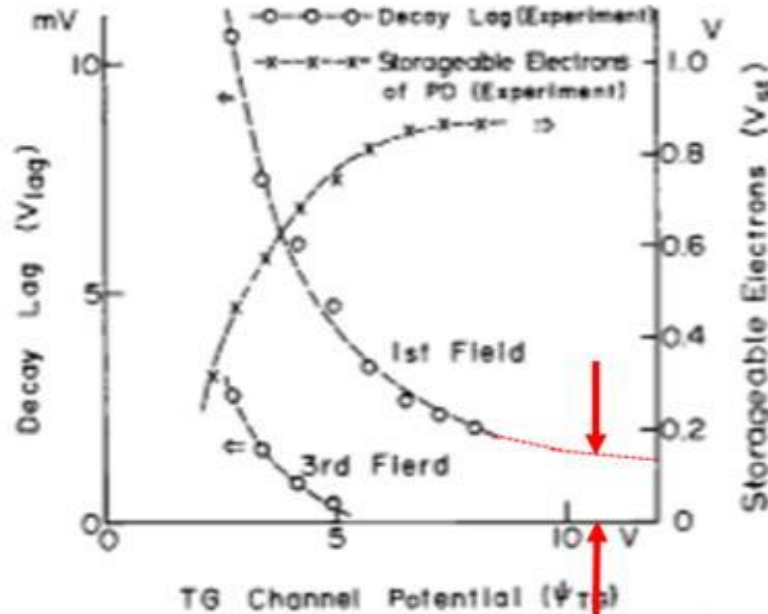
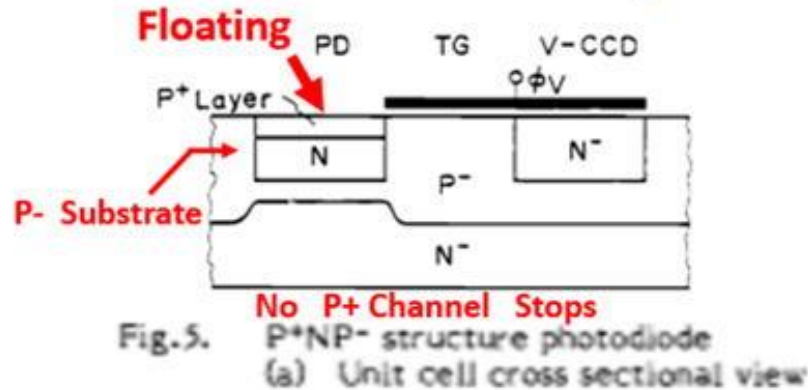

There is still image lag at the CTG gate voltage more than 10 volt.

Fig.6. Storageable electrons vs. transfer gate channel potential, and decay lag vs. transfer gate channel potential in the P+NP- structure photodiode

Hagiwara invented Pinned Photodiode (PPD).

Japanese Patent Applications, JPA1975-127646, JPA1975-127647 and JPA 1975-134985, filed by Yoshiaki Hagiwara at Sony in 1975, show that Hagiwara invented Buried Photodiode (BPD) with the Pinned Surface Hole Accumulation, Pinned Photodiode (PPD) and Hole Accumulation Diode (HAD). It is also evident that Hagiwara invented Global Shutter Scheme of the three level clocking with MOS Capacitor Buffer Memory, clearly shown in JPA 1975-127646 and JPA 1975-127647. It is also evident that Hagiwara et al invented the Electrical Shutter Clocking Scheme by controlling punch-through action of the in-pixel overflow drain (OFD) voltage as evidenced in JPA 1977-136885.

NEC IEDM1982 Paper reported Image Lag

Figure 6 shows that there is still image lag at the CTG gate voltage of > 10 volt.

Difference of Buried Photodiode and Pinned Photodiode

Pinned Photodiode

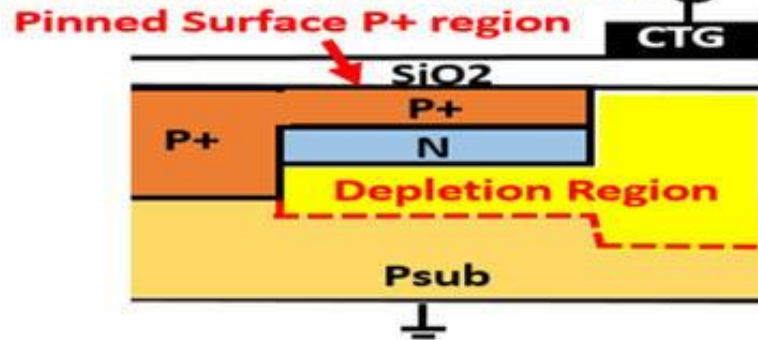

Buried Photodiode

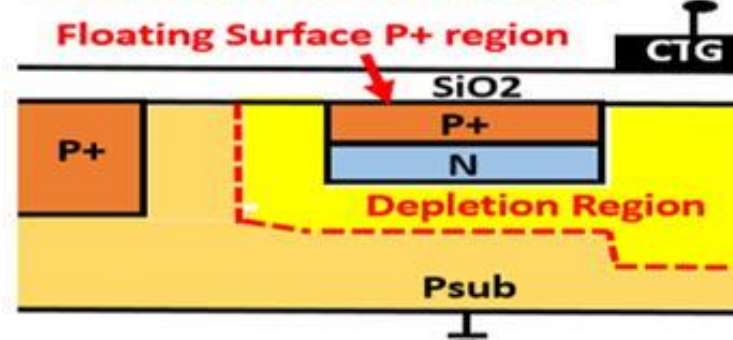

SONY SSDM1978 Paper

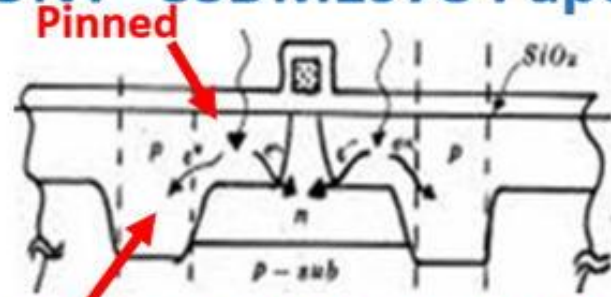

P+ Channel Stops and no Image Lag Problem

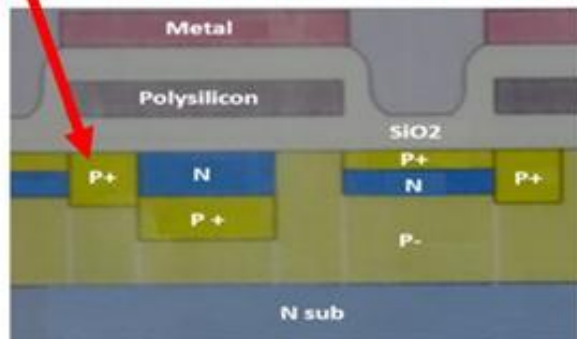

SONY 1987 HAD Sensor

Serious Image Lag Problem

NEC IEDM1982 Paper

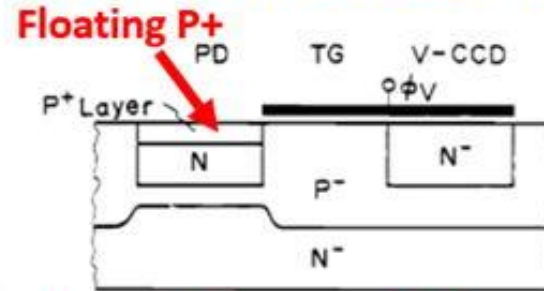

No P+ Channel Stops and Serious Image Lag

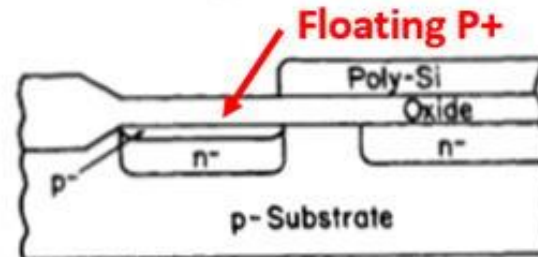

KODAK IEDM1984 Paper

Hagiwara invented Pinned Photodiode (PPD).

Japanese Patent Applications, JPA1975-127646, JPA1975-127647 and JPA 1975-134985, filed by Yoshiaki Hagiwara at Sony in 1975, show that Hagiwara invented Buried Photodiode (BPD) with the Pinned Surface Hole Accumulation, Pinned Photodiode (PPD) and Hole Accumulation Diode (HAD). It is also evident that Hagiwara invented Global Shutter Scheme of the three level clocking with MOS Capacitor Buffer Memory, clearly shown in JPA 1975-127646 and JPA 1975-127647. It is also evident that Hagiwara et al invented the Electrical Shutter Clocking Scheme by controlling punch-thru action of the in-pixel overflow drain (OFD) voltage as evidenced in JPA 1977-136885.

Difference of Pinned Photodiode and Buried Photodiode

Pinned Photodiode must have the P+ heavy doped channel stops nearby.

Pinned Photodiode must be a buried photodiode.

Pinned Photodiode must not have the edge barrier to the Charge Transfer Gate

Pinned Buried Photodiode does not have the edge barrier

Buried Photodiode with the edge barrier

Bucket Brigade Device (BBD) with Serious Image Lag

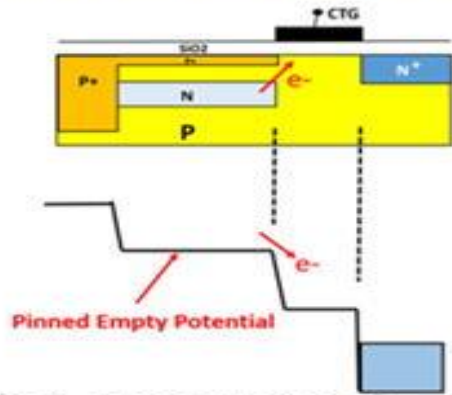

(1) Pinned Photodiode with No Image Lag

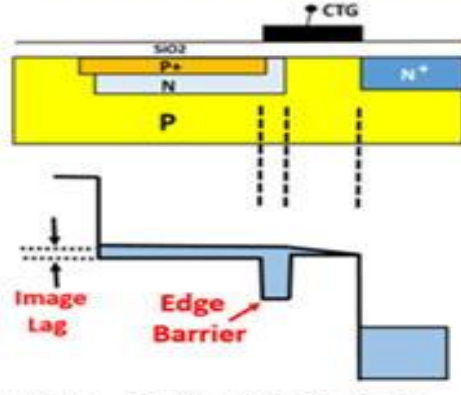

(2) Buried Photodiode with BBD Barrier

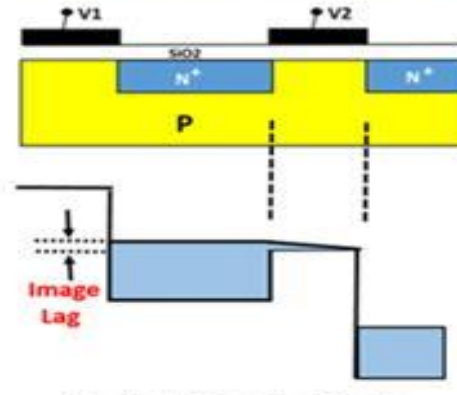

(3) Bucket Brigade Device (BBD)

The surface P+ region may not be pinned, being isolated from the LOCOS P+ channel stop region by the buried N storage region.

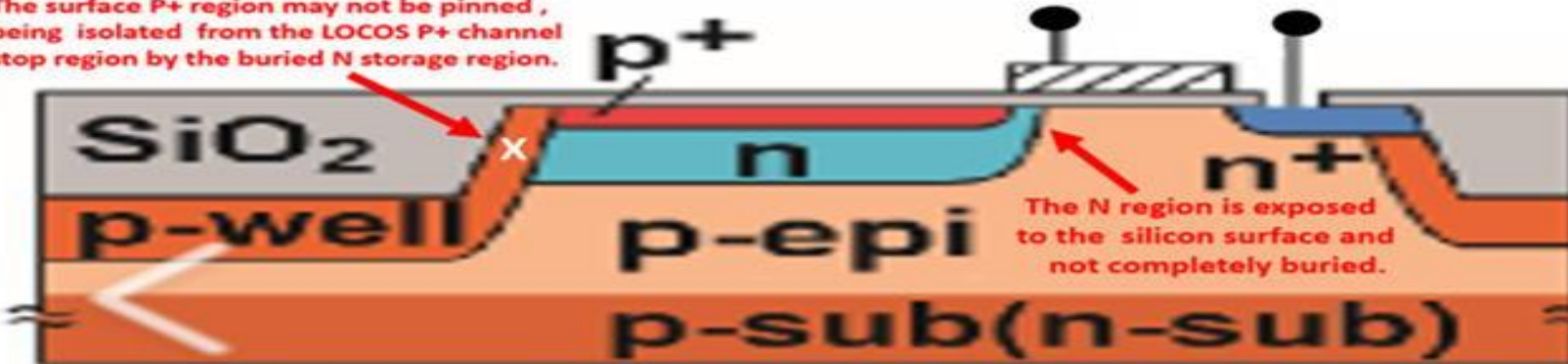

This photodiode is not Pinned Photodiode since the N storage region is not completely buried.

Hagiwara invented Pinned Photodiode (PPD).

Japanese Patent Applications, JPA1975-127646, JPA1975-127647 and JPA 1975-134985, filed by Yoshiaki Hagiwara at Sony in 1975, show that Hagiwara invented Buried Photodiode (BPD) with the Pinned Surface Hole Accumulation, Pinned Photodiode (PPD) and Hole Accumulation Diode (HAD). It is also evident that Hagiwara invented Global Shutter Scheme of the three level clocking with MOS Capacitor Buffer Memory, clearly shown in JPA 1975-127646 and JPA 1975-127647. It is also evident that Hagiwara et al invented the Electrical Shutter Clocking Scheme by controlling punch-thru action of the in-pixel overflow drain (OFD) voltage as evidenced in JPA 1977-136885.

Albert J.P. Theuwissen, Jan T.J. Bosiers, Edwin Roks, "The Hole Role", an invited paper at IEDM2005, Washington DC, Techn. Dig. , 2005.

But in the case that parts of the depleted n-type CCD channels are not covered by gate material, their surface potential is undefined! Such a structure will suffer from charge transport issues during operation, because charge can be trapped in local potential pockets. The effect can be solved by defining the potential in the open areas through an extension of the p⁺ channel stopper. A simple self-aligned implant of 2×10^{13} /cm² boron ions is sufficient to extend the channel stop areas to the gate edge and consequently fix the potential in the open areas [2]. The result after this self-aligned implant is shown in Figure 3. The presence of enough holes plays a crucial role in fixing the potential for the regions "beyond control" of the gates. (Is this structure the mother of the pinned-photodiode or buried diode or hole-accumulation device?)

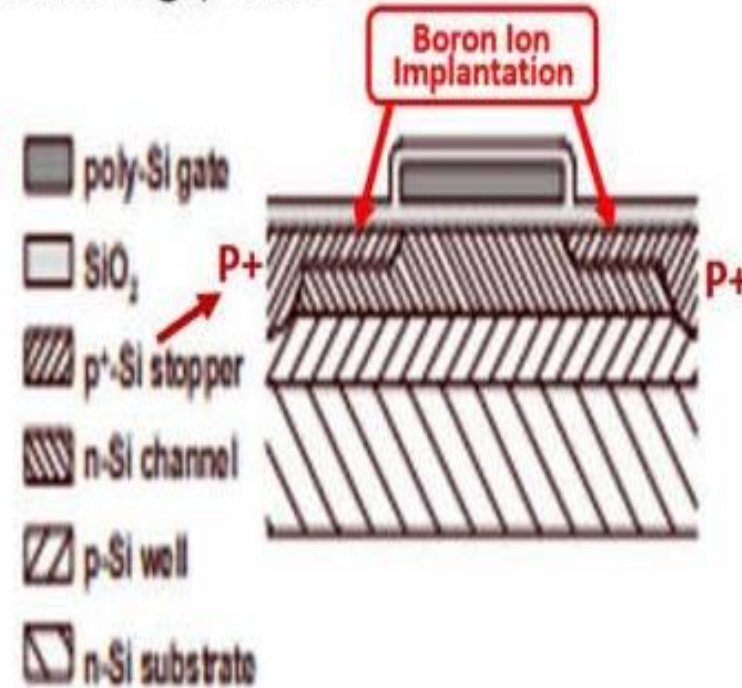

Figure 3. Cross section of a buried-channel CCD on n-Si substrate including light windows and pinned interface potential in the non-covered CCD channels (the cross section is made perpendicular to the CCD channel).

[2] Y. Daimon-Hagiwara et.al., Proc. 10th Conf. on Solid-State Devices, Tokyo, 1978, pp.335-340,

Hagiwara invented Pinned Photodiode (PPD).

Japanese Patent Applications, JPA1975-127646, JPA1975-127647 and JPA 1975-134985, filed by Yoshiaki Hagiwara at Sony in 1975, show that Hagiwara invented Buried Photodiode (BPD) with the Pinned Surface Hole Accumulation, Pinned Photodiode (PPD) and Hole Accumulation Diode (HAD). It is also evident that Hagiwara invented Global Shutter Scheme of the three level clocking with MOS Capacitor Buffer Memory, clearly shown in JPA 1975-127646 and JPA 1975-127647. It is also evident that Hagiwara et al invented the Electrical Shutter Clocking Scheme by controlling punch-thru action of the in-pixel overflow drain (OFD) voltage as evidenced in JPA 1977-136885.

Fossum insulted in his 2014 paper Sony and Hagiwara 1975 PPD invention.

Indeed, Hagiwara invented PPD with VOD and the virtual charge transfer in 1975 !!

IEEE JOURNAL OF THE ELECTRON DEVICES SOCIETY, VOL. 2, NO. 3, MAY 2014

33

Sony HAD (PPD+VOD) does not use LOCOS !!!

A Review of the Pinned Photodiode for CCD and CMOS Image Sensors

Eric R. Fossum, *Fellow, IEEE*, and Donald B. Hondongwa, *Student Member, IEEE*

False

Many people now said this is a fake paper !

C. Other Contributions to the PPD Invention

The PPD structure, while invented for low lag ILT CCD application, shares a strong resemblance to the Hyneccek virtual-phase CCD structure, with the exception of the VOD. The two inventions were solving different problems with essentially the same device structure and operating principles.

In 1975, Hagiwara at Sony filed a patent application on bipolar structures for CCDs in which a *pnp* vertical structure was disclosed, among several structures [24]. The top *p* layer was connected by metal to a bias used to control full-well capacity and the *n*-type base layer was proposed for carrier storage. In an unusual paper, Hagiwara, in 1996, revisited the 1975 invention and claimed it was essentially the invention of both the virtual phase CCD and the NEC low-lag structures, as well as the basis of the Sony so-called "Hole Accumulation Diode," or HAD structure [25]. However, the 1975 application

False

did not address complete charge transfer, lag or anti-blooming properties found in the NEC low-lag device, and does not seem to contain the built-in potential step and charge transfer device aspects of the virtual-phase CCD. Hagiwara repeats these claims in a 2001 paper [26] and shows a VOD structure that is not found in the 1975 patent application. Sony did not seem to pursue the HAD structure until well after the

NEC paper was published. However, the "narrow-gate" CCD with an open *p*-type surface region for improved QE also disclosed in the 1975 application was reported in more detail by Hagiwara et al. at Sony in 1978 [27]. A similar structure was used extensively by Philips [28].

The PPD, as it is most commonly used today, bears the strongest resemblance to the Teranishi et al. ILT CCD device. Thus, these days Teranishi is considered as the primary inventor of the modern PPD [29].

The surface P+ layer is NOT connected to the LOCOS P+ layer. The surface P+ layer may be floating and this photodiode may have serious image lag.

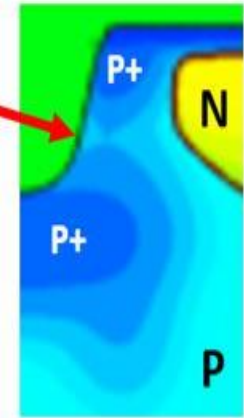

Serious Image Lag ?

NOT connected

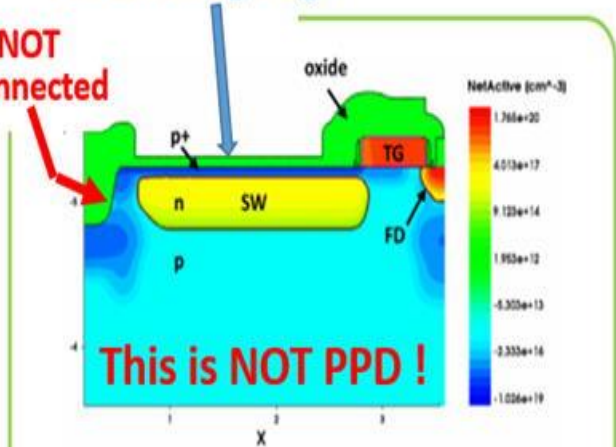

Fig. 4. Example of a pinned photodiode implemented in a CMOS image sensor showing doping concentrations. (Dimensional units are microns).

This is NOT PPD !

Hagiwara invented Pinned Photodiode (PPD).

Japanese Patent Applications, JPA1975-127646, JPA1975-127647 and JPA 1975-134985, filed by Yoshiaki Hagiwara at Sony in 1975, show that Hagiwara invented Buried Photodiode (BPD) with the Pinned Surface Hole Accumulation, Pinned Photodiode (PPD) and Hole Accumulation Diode (HAD). It is also evident that Hagiwara invented Global Shutter Scheme of the three level clocking with MOS Capacitor Buffer Memory, clearly shown in JPA 1975-127646 and JPA 1975-127647. It is also evident that Hagiwara et al invented the Electrical Shutter Clocking Scheme by controlling punch-through action of the in-pixel overflow drain (OFD) voltage as evidenced in JPA 1977-136885.

Hagiwara in 1975 invented PPD with VOD and the virtual charge transfer. Study the Japanese Patents 1975-127646, 1975-127647 and 1975-134985.

Difference between Buried Photodiode and Pinned Photodiode

What is the difference between Buried Photodiode and Pinned Photodiode? I understand that the P+/N/P structure where the P+ and P layers have the same potential is the Pinned Photodiode. So what is the buried Photodiode?

<https://electronics.stackexchange.com/questions/83018/difference-between-buried-photodiode-and-pinned-photodiode>

PIN diode

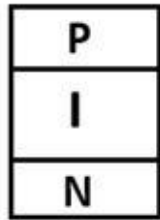

In 1975 the first PPD was invented by Hagiwara at Sony and used in ILT CCD PDs by Hamazaki at Sony in 1987.

PPD must have the P+ channel stops nearby to pin the surface P+ layer.

This is a commonly misunderstood misused set of terminologies.

First off these are not PIN Photodiodes - which stands for P - Intrinsic- N. These have large depletion regions for higher internal QE (Quantum Efficiency) and faster response. You can't make an array with this design though.

Pinning, refers to fermi-level pinning or pinning to a certain voltage level. Or also the forcing or prevention of the fermi-level/voltage from moving in energy space.

You can get surface state pinning from the dangling Si/SiO₂ bonds providing trapping centers. A buried PD (Photodiode) has a shallow implant that forces the charge carriers away from these surface traps. The Si/SiO₂ surface contributes to increased leakage (dark current) and noise (particularly 1/f noise from trapping/de-trapping). So confusingly a buried PD avoids pinning of the fermi-level at the surface.

A pinned PD is by necessity a buried PD, but not all buried PD's are pinned. The first Pinned PD was invented by Hagiwara at Sony and is used in ILT CCD PD's, these same PD's and the principles behind this complete transfer of charge are used in most CMOS imagers built today.

A pinned PD is designed to have the collection region deplete out when reset. AS the PD depletes it becomes disconnected from the readout circuit and if designed properly will drain all charge out of the collection region (accomplishing complete charge transfer). An interesting side effect is that the capacitance of the PD drops to effectively zero and therefore the KTC noise $q_n = \sqrt{KTC}$ also goes to zero. When you design the depletion of the PD to deplete at a certain voltage you are pinning that PD to that voltage. That is where the term comes from.

I've edited this Answer to acknowledge Hagiwara-san's contribution. It has long been incorrectly attributed to Teranishi and to Fossum (in CMOS image sensors)

Hagiwara invented Pinned Photodiode (PPD).

Japanese Patent Applications, JPA1975-127646, JPA1975-127647 and JPA 1975-134985, filed by Yoshiaki Hagiwara at Sony in 1975, show that Hagiwara invented Buried Photodiode (BPD) with the Pinned Surface Hole Accumulation, Pinned Photodiode (PPD) and Hole Accumulation Diode (HAD). It is also evident that Hagiwara invented Global Shutter Scheme of the three level clocking with MOS Capacitor Buffer Memory, clearly shown in JPA 1975-127646 and JPA 1975-127647. It is also evident that Hagiwara et al invented the Electrical Shutter Clocking Scheme by controlling punch-thru action of the in-pixel overflow drain (OFD) voltage as evidenced in JPA 1977-136885.

<https://www.shmj.or.jp/english/pdf/dis/exhibi1005E.pdf>

In 1975, Sony proposed using a PNP transistor as the photodetector [3]. By providing a P + layer (emitter) for the light incident section, the sensor electrode that covers the entire light receiving surface of the photodiode can be eliminated, greatly improving the light sensitivity. This P + layer was also a proposal to reduce the dark current and image lag which became the basis of the pinned photodiode.

In 1978, Sony presented a 93,000-pixel FT (Frame Transfer) -CCD image sensor compliant with the Analog TV Broadcasting Standard (SDTV) for the first time in the world [5], using the photodiode with the same structure as above. Sony succeeded in 1981 in trial production of a VTR-integrated color movie camera using a 2 / 3-inch 280,000-pixel FT-CCD image sensor by further improvement of this technology [6].

The Pinned Photodiode is a photodiode in which the entire N layer is covered with a P layer. The part of the P layer on the light incident surface is heavily doped P+ (Fig-1). Kodak named this structure Pinned Photodiode in 1984 because the P + surface of the light incident surface was pinned to the substrate potential. This device has features such as high light sensitivity, wide dynamic range, image lag free, much smaller dark current due to reduced influence of GR center on the light receiving surface, and no white scars.

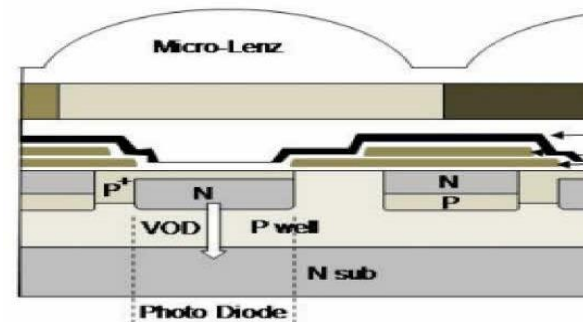
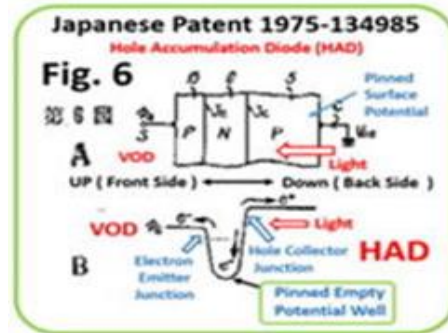
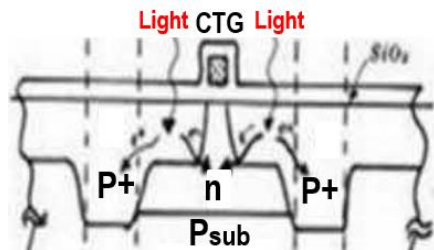

Pinned Photodiode reported at SSDM 1978

References:

- [1] M. Hamasaki, T. Suzuki, Y. Kagawa, K. Ishikawa, K. Miyata and H. Kambe, "An IT-CCD imager with electronically variable shutter speed", Technical Report of The Institute of Image Information and Television Engineers, vol. 12, no. 12, pp. 31-36, (1988)
- [3] Y. Hagiwara, Japanese Patent JP1975—134985
- [5] Y. Hagiwara, M. Abe, and C. Okada, "A 380H x 488V CCD imager with narrow channel transfer gates", Proc. The 10th Conference on Solid State Devices, Tokyo, (1978); Japanese Journal of Applied Physics, vol. 18, Supplements 18-1, pp. 335-340, (1979)
- [6] I. Kajino, M. Shimada, Y. Nakada, Y. Hirata and Y. Hagiwara, "Single Chip Color Camera Using Narrow channel CCD Imager with Over Flow Drain", Technical Report of The Institute of Image Information and Television Engineers, vol. 5, no. 29, pp.

Hagiwara invented Pinned Photodiode (PPD).

Japanese Patent Applications, JPA1975-127646, JPA1975-127647 and JPA 1975-134985, filed by Yoshiaki Hagiwara at Sony in 1975, show that Hagiwara invented Buried Photodiode (BPD) with the Pinned Surface Hole Accumulation, Pinned Photodiode (PPD) and Hole Accumulation Diode (HAD). It is also evident that Hagiwara invented Global Shutter Scheme of the three level clocking with MOS Capacitor Buffer Memory, clearly shown in JPA 1975-127646 and JPA 1975-127647. It is also evident that Hagiwara et al invented the Electrical Shutter Clocking Scheme by controlling punch-through action of the in-pixel overflow drain (OFD) voltage as evidenced in JPA 1977-136885.

Sony's Representative Inventions Supporting Stacked Multi-Functional CMOS Image Sensors

Sony Corporation
Sony Semiconductor Solutions Corporation

<https://www.sony.net/SonyInfo/News/notice/20200626/>

Pinned Photodiode Adopted for Back-Illuminated CMOS Image Sensors

The history of Sony's inventions of image sensors goes back to the CCD era. Above all, Pinned Photodiode is a technology that contributes to improving the performance of back-illuminated CMOS image sensors, and the history of inventions and product development are as below.

In 1975, Sony invented a CCD image sensor that adopted a back-illuminated N+NP+N junction type and an N+NP+NP junction type Pinned Photodiode (PPD) (Japanese patent application number 1975-127646, 1975-127647 [Yoshiaki Hagiwara](#)). In the same year, inspired by such structure, Sony invented a PNP junction type PPD with VOD (vertical overflow drain) function (Japanese Patent No. 1215101 [Yoshiaki Hagiwara](#)). After that, Sony succeeded in making a principle prototype of a frame transfer CCD image sensor that adopted the PNP junction type PPD technology, having a high-impurity-concentration P+ channel stop region formed near a light receiving section by ion implantation technology for the first time in the world, and its technical paper was presented at the academic conference, SSDM 1978 ([Y. Hagiwara](#), M. Abe, and C. Okada, "A 380H x 488V CCD imager with narrow channel transfer gates", Proc. The 10th Conference on Solid State Devices, Tokyo, (1978)). In 1980, Sony succeeded in making a camera integrated VTR which incorporated a one-chip frame transfer CCD image sensor that adopted the PNP junction type PPD. President Iwama in Tokyo, Chairperson Morita in New York, at the time held a press conference respectively on the same day, which surprised the world. In 1987, Sony succeeded in developing a 8 mm video camcorder that adopted, for the first time in the world, the interline transfer CCD image sensor, which incorporated "PPD having a high-impurity-concentration P+ channel stop region formed near the light receiving section by ion implantation technology" with VOD function, and became the pioneer of the video camera market. The PPD technology that has been nurtured through such a long history is still used in back-illuminated CMOS image sensors.

References:

- 【1】 M. Hamasaki, T. Suzuki, Y. Kagawa, K. Ishikawa, K. Miyata and H. Kambe, "An IT-CCD imager with electronically variable shutter speed", Technical Report of The Institute of Image Information and Television Engineers, vol. 12, no. 12, pp. 31-36, (1988)
- 【3】 [Y. Hagiwara](#), Japanese Patent JP1975—134985
- 【5】 [Y. Hagiwara](#), M. Abe, and C. Okada, "A 380H x 488V CCD imager with narrow channel transfer gates", Proc. The 10th Conference on Solid State Devices, Tokyo, (1978); Japanese Journal of Applied Physics, vol. 18, Supplements 18-1, pp. 335-340, (1979)
- 【6】 I. Kajino, M. Shimada, Y. Nakada, Y. Hirata and [Y. Hagiwara](#), "Single Chip Color Camera Using Narrow channel CCD Imager with Over Flow Drain", Technical Report of The Institute of Image Information and Television Engineers, vol. 5, no. 29, pp. 152

Hagiwara invented Pinned Photodiode (PPD).

Japanese Patent Applications, JPA1975-127646, JPA1975-127647 and JPA 1975-134985, filed by Yoshiaki Hagiwara at Sony in 1975, show that Hagiwara invented Buried Photodiode (BPD) with the Pinned Surface Hole Accumulation, Pinned Photodiode (PPD) and Hole Accumulation Diode (HAD). It is also evident that Hagiwara invented Global Shutter Scheme of the three level clocking with MOS Capacitor Buffer Memory, clearly shown in JPA 1975-127646 and JPA 1975-127647. It is also evident that Hagiwara et al invented the Electrical Shutter Clocking Scheme by controlling punch-thru action of the in-pixel overflow drain (OFD) voltage as evidenced in JPA 1977-136885.



ISSCC2013 - San Francisco, Feb 18 2013

<http://isscc.org/>



International Solid State Circuits Conference

1954-2013

Hagiwara invented Pinned Photodiode (PPD).

Japanese Patent Applications, JPA1975-127646, JPA1975-127647 and JPA 1975-134985, filed by Yoshiaki Hagiwara at Sony in 1975, show that Hagiwara invented Buried Photodiode (BPD) with the Pinned Surface Hole Accumulation, Pinned Photodiode (PPD) and Hole Accumulation Diode (HAD). It is also evident that Hagiwara invented Global Shutter Scheme of the three level clocking with MOS Capacitor Buffer Memory, clearly shown in JPA 1975-127646 and JPA 1975-127647. It is also evident that Hagiwara et al invented the Electrical Shutter Clocking Scheme by controlling punch-thru action of the in-pixel overflow drain (OFD) voltage as evidenced in JPA 1977-136885.



Hagiwara invented Pinned Photodiode (PPD).

Japanese Patent Applications, JPA1975-127646, JPA1975-127647 and JPA 1975-134985, filed by Yoshiaki Hagiwara at Sony in 1975, show that Hagiwara invented Buried Photodiode (BPD) with the Pinned Surface Hole Accumulation, Pinned Photodiode (PPD) and Hole Accumulation Diode (HAD). It is also evident that Hagiwara invented Global Shutter Scheme of the three level clocking with MOS Capacitor Buffer Memory, clearly shown in JPA 1975-127646 and JPA 1975-127647. It is also evident that Hagiwara et al invented the Electrical Shutter Clocking Scheme by controlling punch-thru action of the in-pixel overflow drain (OFD) voltage as evidenced in JPA 1977-136885.



Yoshiaki Hagiwara: The p-n-p-n Diode in Future Linear Motor Cars and in Modern Imagers

John Louis Moll (1921–2011) was studying a p-n-p-n diode switch in his Ph.D. dissertation work when the first ISSCC was held in 1954. In a normal operation mode, this device works as a thyristor, which can drive a large current and is the key device structure of an IGBT applied for a linear motor car of the future (see Figure 9). In a dynamic operation mode, this device may work as a simple p-n-p-n dynamic capacitance that can detect and store one single electron, which is a key device structure of the modern image sensor (see Figure 10).

I recall, when I was taking his physics course at Caltech, that Feynman once said that an electron is always free, moving around rapidly in free space, even in solid, and it never stops. It is very hard to catch an electron because we do not know exactly where it is. Our civilization today is based on a technology that controls electrons, down to a single one.

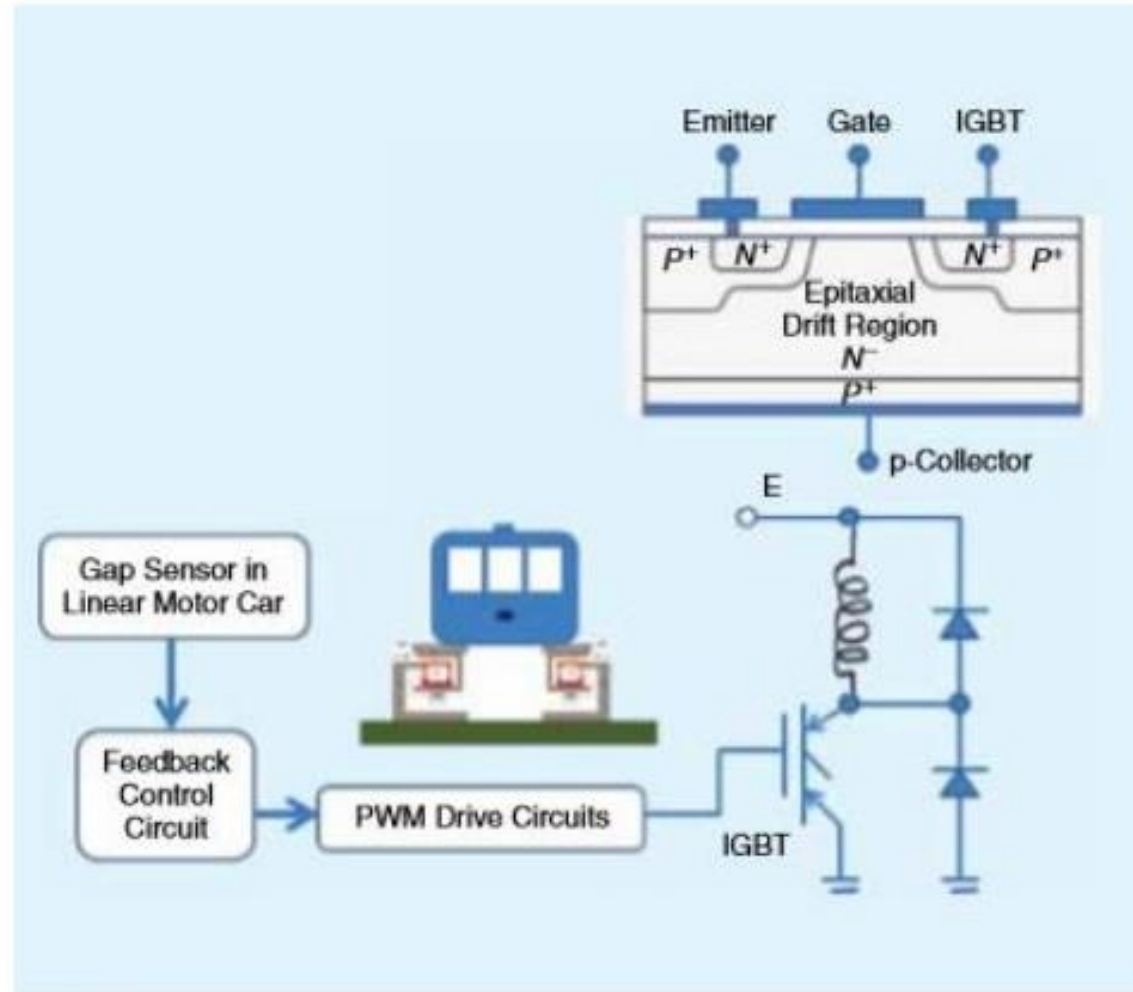

FIGURE 9: The p-n-p-n switch diode for a modern linear motor car.

Hagiwara invented Pinned Photodiode (PPD).

Japanese Patent Applications, JPA1975-127646, JPA1975-127647 and JPA 1975-134985, filed by Yoshiaki Hagiwara at Sony in 1975, show that Hagiwara invented Buried Photodiode (BPD) with the Pinned Surface Hole Accumulation, Pinned Photodiode (PPD) and Hole Accumulation Diode (HAD). It is also evident that Hagiwara invented Global Shutter Scheme of the three level clocking with MOS Capacitor Buffer Memory, clearly shown in JPA 1975-127646 and JPA 1975-127647. It is also evident that Hagiwara et al invented the Electrical Shutter Clocking Scheme by controlling punch-thru action of the in-pixel overflow drain (OFD) voltage as evidenced in JPA 1977-136885.

Imagine a photon incident to a bipolar transistor base region. The photon energy creates an electron-hole pair. And the photo-electron can be stored in the base region as one single majority carrier. That is, a bipolar transistor can also function as a photon detector and/or a storage container. I thought that a room in a hotel must be empty and clean before the first hotel guest arrives. So must be this transistor base region empty and clean with no guest electrons at the beginning. This transistor in a dynamic p-n-p capacitor mode is useful since it can capture, confine, and control one single electron. But as a student, I did not know yet how to student, I did not know yet how to move that single photoelectron sitting in the base region to the outside world so that we can make use of it as a signal. I had no way yet to know whether the hotel guest has arrived and is resting in the hotel room or not. We had no way yet to ask the hotel guest to come up to the hotel lobby to meet me. I had to wait a few more years (until 1970

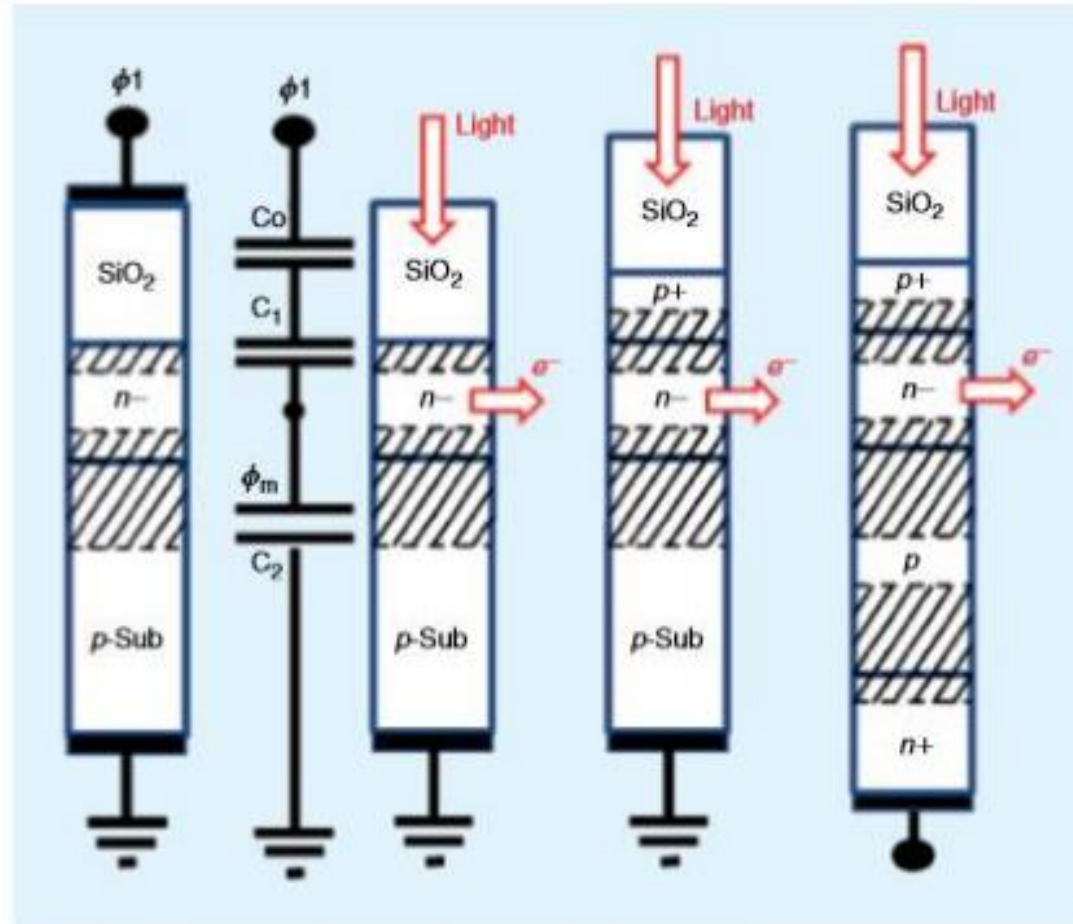

FIGURE 10: From CCD to the dynamic p-n-p-n diode capacitors.

in my senior year in college) to find the answer. We all know now it is the CCD structure that can store and transfer one single electron. With a precharge reset set gate and

With a precharge reset set gate and a source-follower circuit, a scheme invented by Walter Kosonocky. We could finally meet our hotel guest at the hotel lobby.

Hagiwara invented Pinned Photodiode (PPD).

Japanese Patent Applications, JPA1975-127646, JPA1975-127647 and JPA 1975-134985, filed by Yoshiaki Hagiwara at Sony in 1975, show that Hagiwara invented Buried Photodiode (BPD) with the Pinned Surface Hole Accumulation, Pinned Photodiode (PPD) and Hole Accumulation Diode (HAD). It is also evident that Hagiwara invented Global Shutter Scheme of the three level clocking with MOS Capacitor Buffer Memory, clearly shown in JPA 1975-127646 and JPA 1975-127647. It is also evident that Hagiwara et al invented the Electrical Shutter Clocking Scheme by controlling punch-thru action of the in-pixel overflow drain (OFD) voltage as evidenced in JPA 1977-136885.

**History of dynamic Solid State image sensing structure
from BCCD type MOS capacitor to the P+NPN junction Pinned Photodiode capacitor**

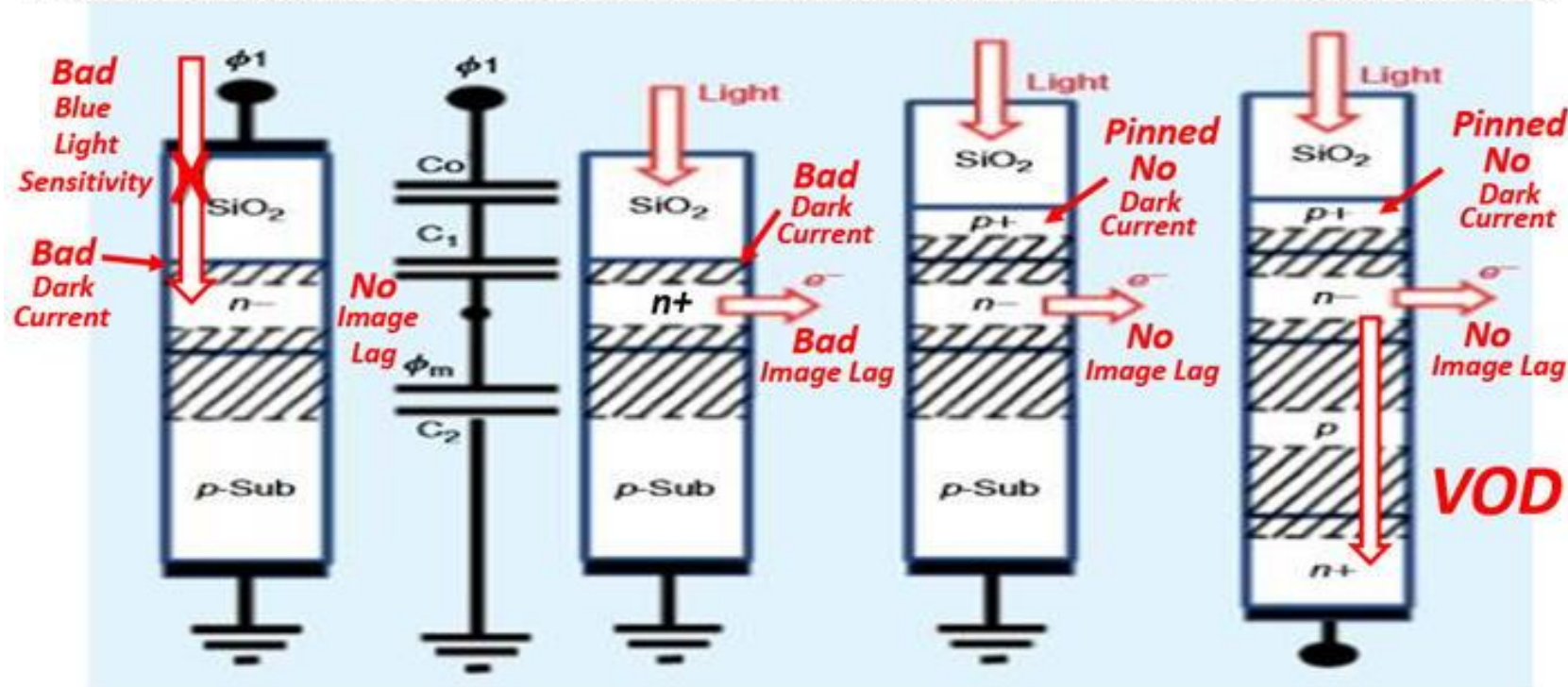

(1) CCD type invented by Bell Lab in 1968
(2) N+P type The classical photodiode with serious image lag
(3) P+NP type and **(4) P+NPN type** are the P+NP junction type Pinned Photodiode invented by Yoshiaki Hagiwara, 1975

In Japanese patent 1975-134985, Hagiwara at Sony invented the Pinned photodiode with very low dark current, which is also the completely depleted Buried Photodiode with image lag free picture quality, and also with the built-in vertical overflow drain (VOD) function.

Reference: IEEE Solid-STATE CIRCUITS MAGAZINE, SUMMER 2013 issue pp. 6 ~

Hagiwara invented Pinned Photodiode (PPD).

Japanese Patent Applications, JPA1975-127646, JPA1975-127647 and JPA 1975-134985, filed by Yoshiaki Hagiwara at Sony in 1975, show that Hagiwara invented Buried Photodiode (BPD) with the Pinned Surface Hole Accumulation, Pinned Photodiode (PPD) and Hole Accumulation Diode (HAD). It is also evident that Hagiwara invented Global Shutter Scheme of the three level clocking with MOS Capacitor Buffer Memory, clearly shown in JPA 1975-127646 and JPA 1975-127647. It is also evident that Hagiwara et al invented the Electrical Shutter Clocking Scheme by controlling punch-thru action of the in-pixel overflow drain (OFD) voltage as evidenced in JPA 1977-136885.

Difference of the static and dynamic photo transistors are illustrated in these figures.

Sony Hole Accumulation Diode (HAD) is the P+NPNsub junction dynamic photo transistor with the surface P+ hole collecting and accumulation region is pinned and grounded, which is now widely called as Pinned Photodiode with the vertical overflow drain (VOD) function. Only Pinned Photodiode with the VOD function can realize the electrical shutter function.

Hagiwara invented Pinned Photodiode (PPD).

Japanese Patent Applications, JPA1975-127646, JPA1975-127647 and JPA 1975-134985, filed by Yoshiaki Hagiwara at Sony in 1975, show that Hagiwara invented Buried Photodiode (BPD) with the Pinned Surface Hole Accumulation, Pinned Photodiode (PPD) and Hole Accumulation Diode (HAD). It is also evident that Hagiwara invented Global Shutter Scheme of the three level clocking with MOS Capacitor Buffer Memory, clearly shown in JPA 1975-127646 and JPA 1975-127647. It is also evident that Hagiwara et al invented the Electrical Shutter Clocking Scheme by controlling punch-thru action of the in-pixel overflow drain (OFD) voltage as evidenced in JPA 1977-136885.

Difference of the static and dynamic photo transistors are illustrated in these figures.

Sony Hole Accumulation Diode (HAD) is the P+NPNsub junction dynamic photo transistor with the surface P+ hole collecting and accumulation region is pinned and grounded, which is now widely called as Pinned Photodiode with the vertical overflow drain (VOD) function. Only Pinned Photodiode with the VOD function can realize the electrical shutter function.

SONY HAD Sensor 1975 was hinted by SONY PNP Bipolar Transistor Process Technology

Conventional Static Phototransistor

(by John Northrup Shive, 1950)

No memory function is involved.

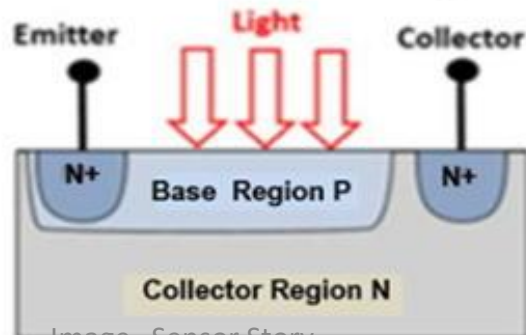
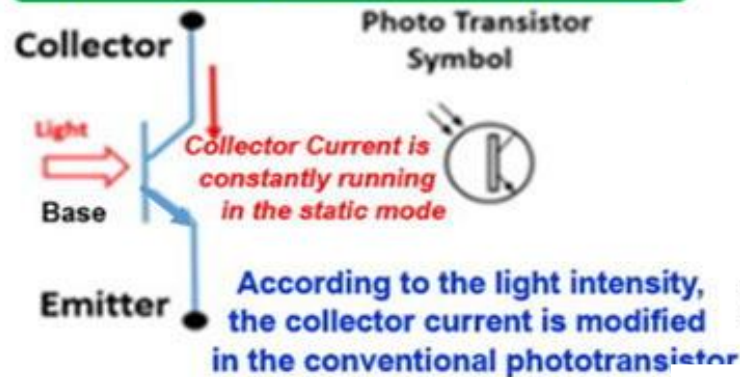

Image - Sensor Story

Hagiwara invented Pinned Photodiode (PPD).

Japanese Patent Applications, JPA1975-127646, JPA1975-127647 and JPA 1975-134985, filed by Yoshiaki Hagiwara at Sony in 1975, show that Hagiwara invented Buried Photodiode (BPD) with the Pinned Surface Hole Accumulation, Pinned Photodiode (PPD) and Hole Accumulation Diode (HAD). It is also evident that Hagiwara invented Global Shutter Scheme of the three level clocking with MOS Capacitor Buffer Memory, clearly shown in JPA 1975-127646 and JPA 1975-127647. It is also evident that Hagiwara et al invented the Electrical Shutter Clocking Scheme by controlling punch-thru action of the in-pixel overflow drain (OFD) voltage as evidenced in JPA 1977-136885.

Difference of the static and dynamic photo transistors are illustrated in these figures.

Sony Hole Accumulation Diode (HAD) is the P+NPNsub junction dynamic photo transistor with the surface P+ hole collecting and accumulation region is pinned and grounded, which is now widely called as Pinned Photodiode with the vertical overflow drain (VOD) function. Only Pinned Photodiode with the VOD function can realize the electrical shutter function.

SONY HAD Sensor 1975 was hinted by SONY PNP Bipolar Transistor Process Technology

Conventional Static Phototransistor

(by John Northrup Shive, 1950)

No memory function is involved.

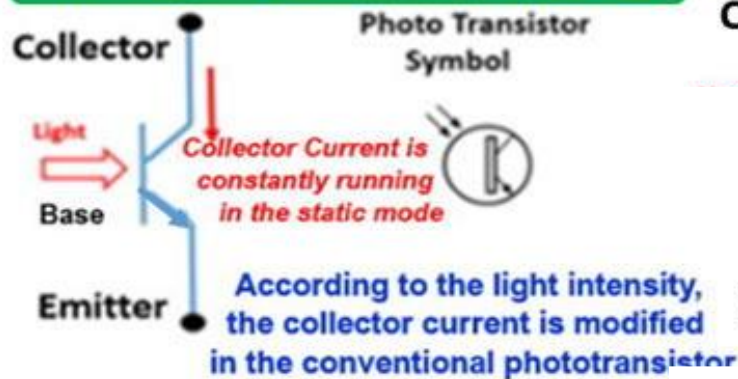

Dynamic Phototransistor Operation
by Yoshiaki Hagiwara at Sony in 1975

Dynamic Memory function is involved.

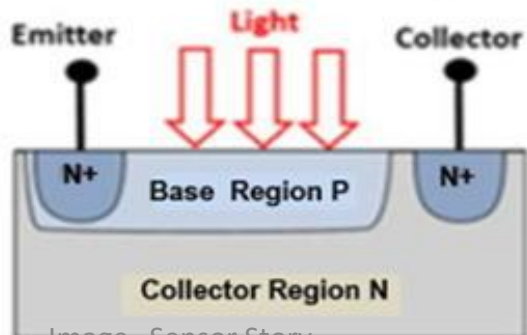
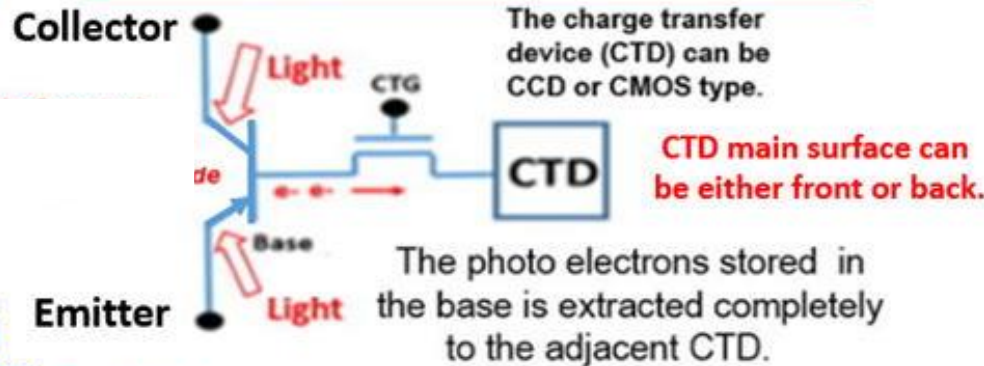

Image - Sensor Story

Hagiwara invented Pinned Photodiode (PPD).

Japanese Patent Applications, JPA1975-127646, JPA1975-127647 and JPA 1975-134985, filed by Yoshiaki Hagiwara at Sony in 1975, show that Hagiwara invented Buried Photodiode (BPD) with the Pinned Surface Hole Accumulation, Pinned Photodiode (PPD) and Hole Accumulation Diode (HAD). It is also evident that Hagiwara invented Global Shutter Scheme of the three level clocking with MOS Capacitor Buffer Memory, clearly shown in JPA 1975-127646 and JPA 1975-127647. It is also evident that Hagiwara et al invented the Electrical Shutter Clocking Scheme by controlling punch-thru action of the in-pixel overflow drain (OFD) voltage as evidenced in JPA 1977-136885.

Difference of the static and dynamic photo transistors are illustrated in these figures.

Sony Hole Accumulation Diode (HAD) is the P+NPNsub junction dynamic photo transistor with the surface P+ hole collecting and accumulation region is pinned and grounded, which is now widely called as Pinned Photodiode with the vertical overflow drain (VOD) function. Only Pinned Photodiode with the VOD function can realize the electrical shutter function.

SONY HAD Sensor 1975 was hinted by SONY PNP Bipolar Transistor Process Technology

Conventional Static Phototransistor

(by John Northrup Shive, 1950)

No memory function is involved.

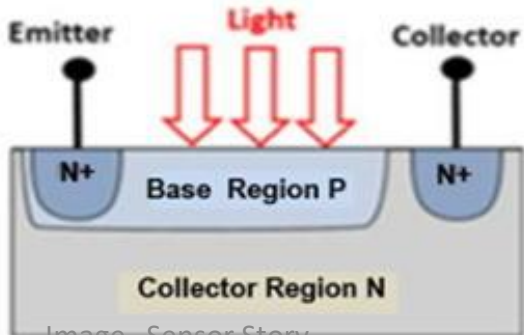
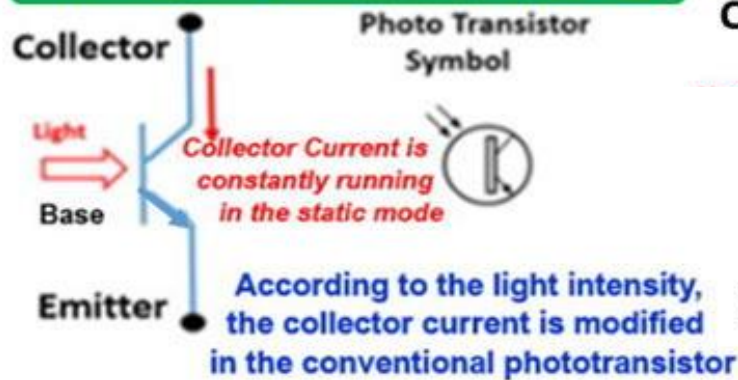
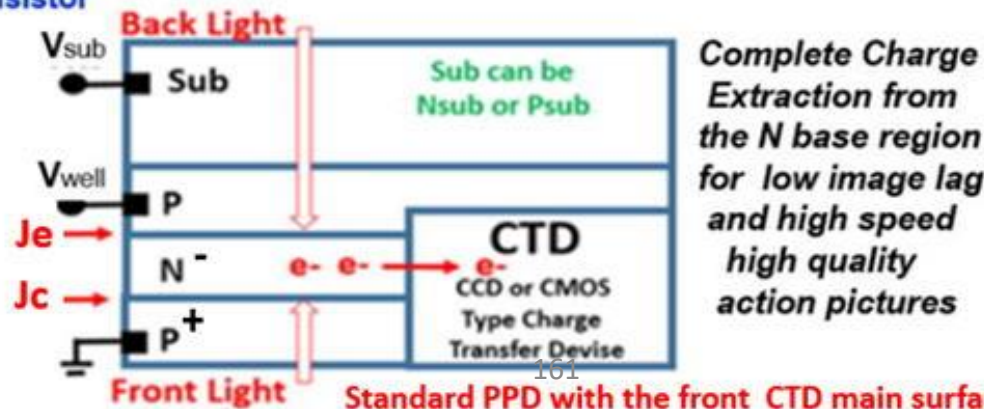
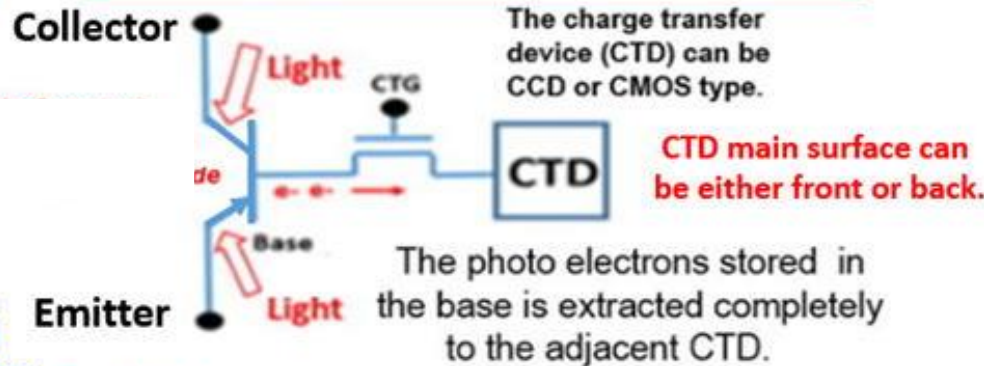

Image - Sensor Story

Dynamic Phototransistor Operation

by Yoshiaki Hagiwara at Sony in 1975

Dynamic Memory function is involved.



Hagiwara invented Pinned Photodiode (PPD).

Japanese Patent Applications, JPA1975-127646, JPA1975-127647 and JPA 1975-134985, filed by Yoshiaki Hagiwara at Sony in 1975, show that Hagiwara invented Buried Photodiode (BPD) with the Pinned Surface Hole Accumulation, Pinned Photodiode (PPD) and Hole Accumulation Diode (HAD). It is also evident that Hagiwara invented Global Shutter Scheme of the three level clocking with MOS Capacitor Buffer Memory, clearly shown in JPA 1975-127646 and JPA 1975-127647. It is also evident that Hagiwara et al invented the Electrical Shutter Clocking Scheme by controlling punch-thru action of the in-pixel overflow drain (OFD) voltage as evidenced in JPA 1977-136885.

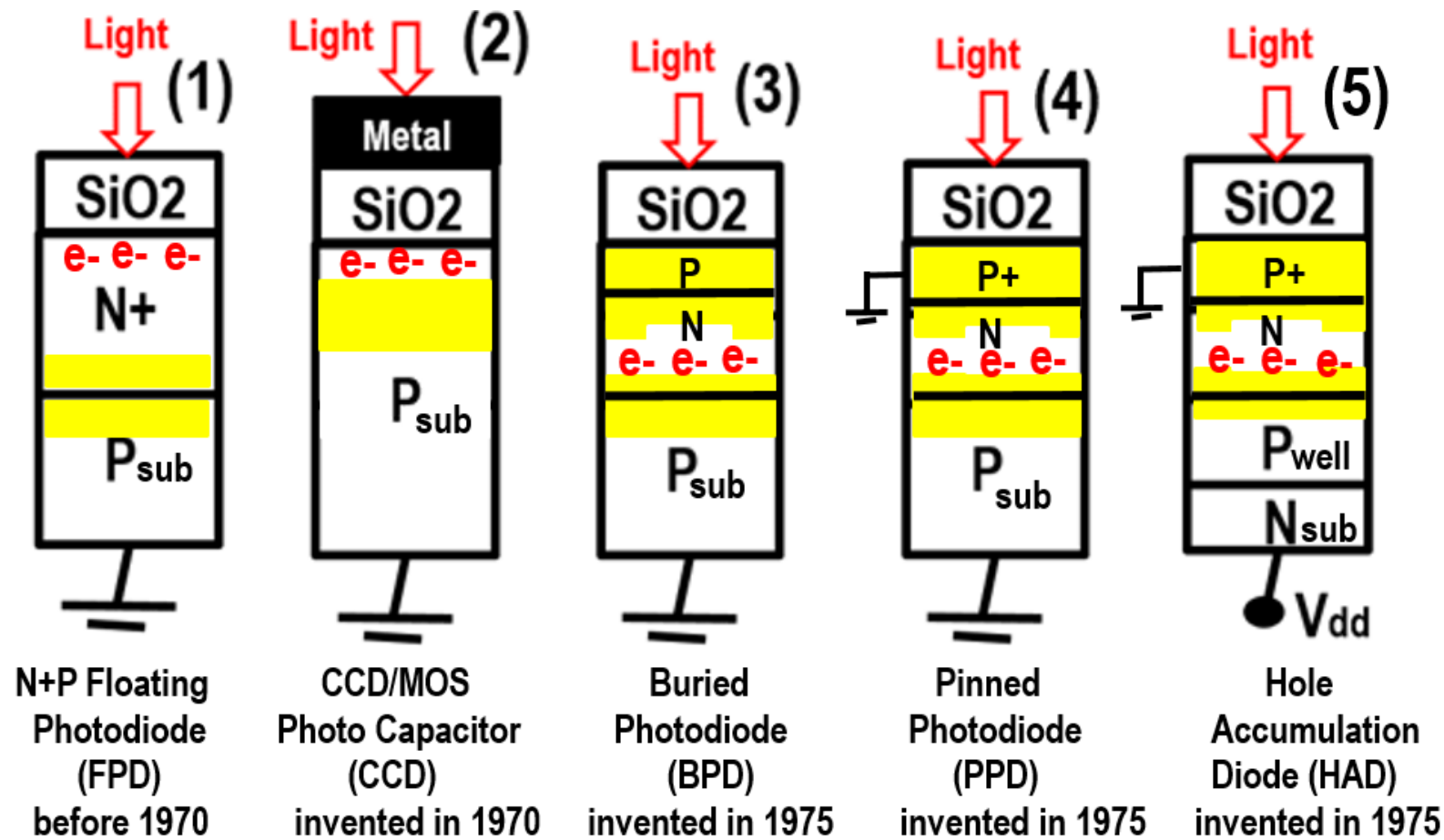

Hagiwara invented Pinned Photodiode (PPD).

Japanese Patent Applications, JPA1975-127646, JPA1975-127647 and JPA 1975-134985, filed by Yoshiaki Hagiwara at Sony in 1975, show that Hagiwara invented Buried Photodiode (BPD) with the Pinned Surface Hole Accumulation, Pinned Photodiode (PPD) and Hole Accumulation Diode (HAD). It is also evident that Hagiwara invented Global Shutter Scheme of the three level clocking with MOS Capacitor Buffer Memory, clearly shown in JPA 1975-127646 and JPA 1975-127647. It is also evident that Hagiwara et al invented the Electrical Shutter Clocking Scheme by controlling punch-thru action of the in-pixel overflow drain (OFD) voltage as evidenced in JPA 1977-136885.

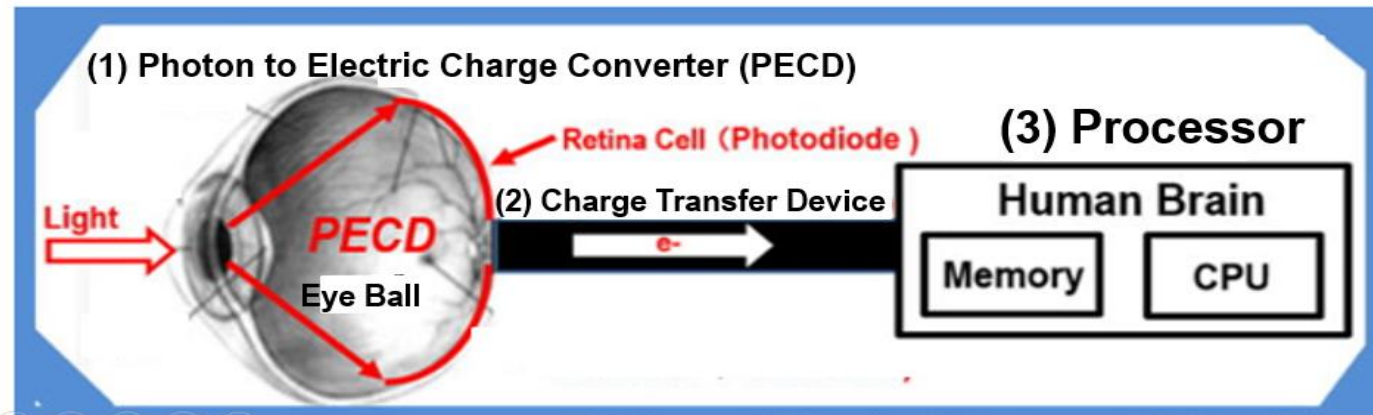

● NPN transistor Current Amplification

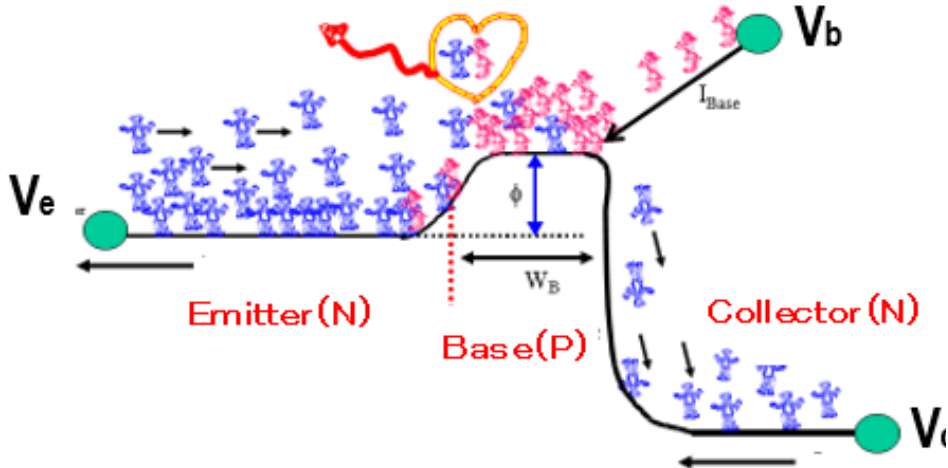

3-D Multi-chips Intelligent CMOS Image Sensor System

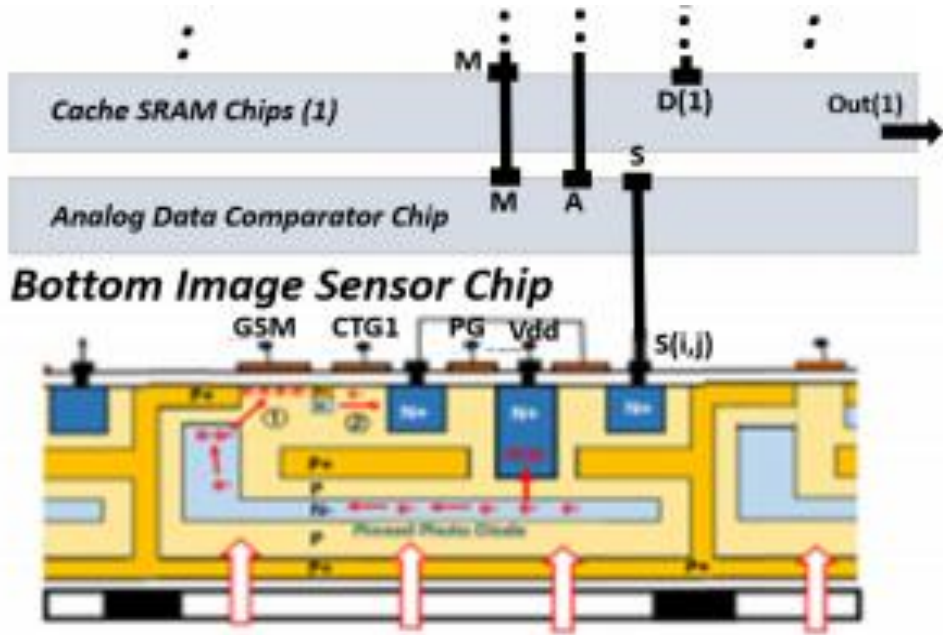

● Low Power CMOS inverter

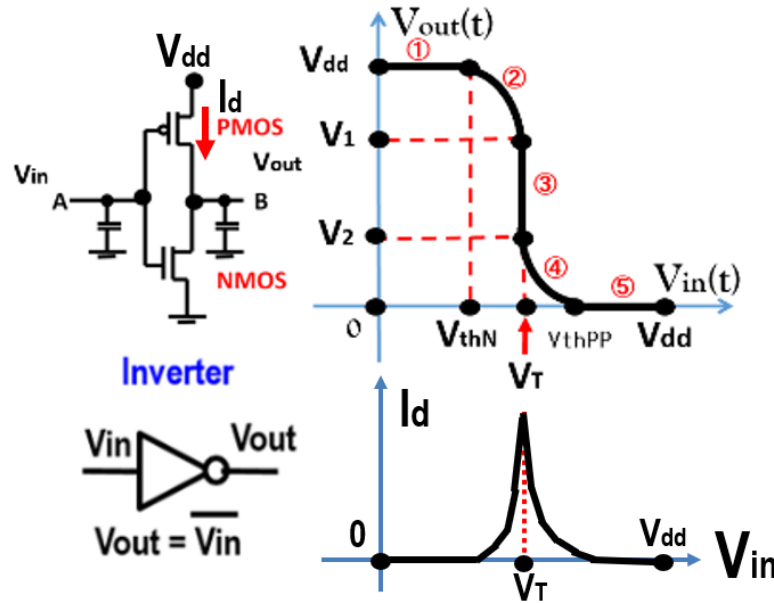

● Water Gate Model for CMOS Inverter

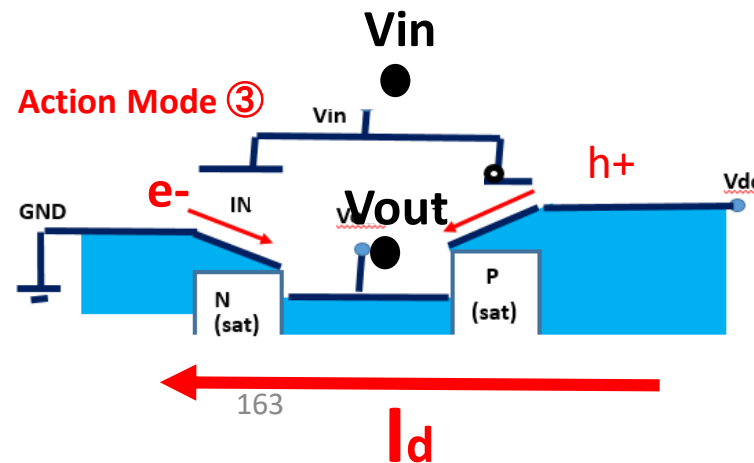

Hagiwara invented Pinned Photodiode (PPD).

Japanese Patent Applications, JPA1975-127646, JPA1975-127647 and JPA 1975-134985, filed by Yoshiaki Hagiwara at Sony in 1975, show that Hagiwara invented Buried Photodiode (BPD) with the Pinned Surface Hole Accumulation, Pinned Photodiode (PPD) and Hole Accumulation Diode (HAD). It is also evident that Hagiwara invented Global Shutter Scheme of the three level clocking with MOS Capacitor Buffer Memory, clearly shown in JPA 1975-127646 and JPA 1975-127647. It is also evident that Hagiwara et al invented the Electrical Shutter Clocking Scheme by controlling punch-thru action of the in-pixel overflow drain (OFD) voltage as evidenced in JPA 1977-136885.

Correlated Double Sampling Hold by Prof. M. White, 1972

Conventional Single Sampling Hold

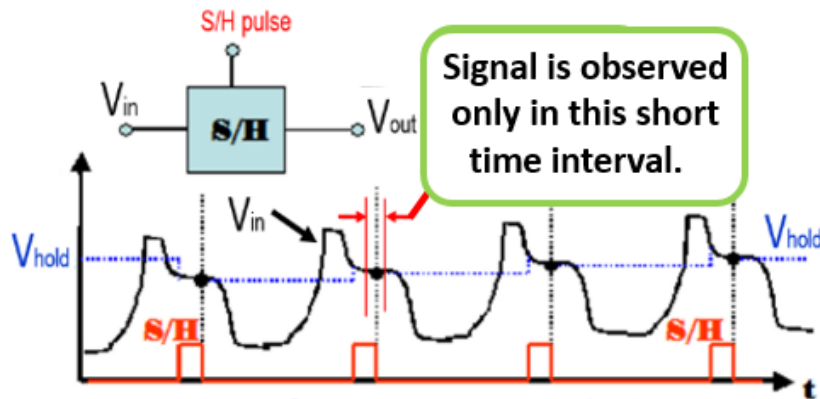
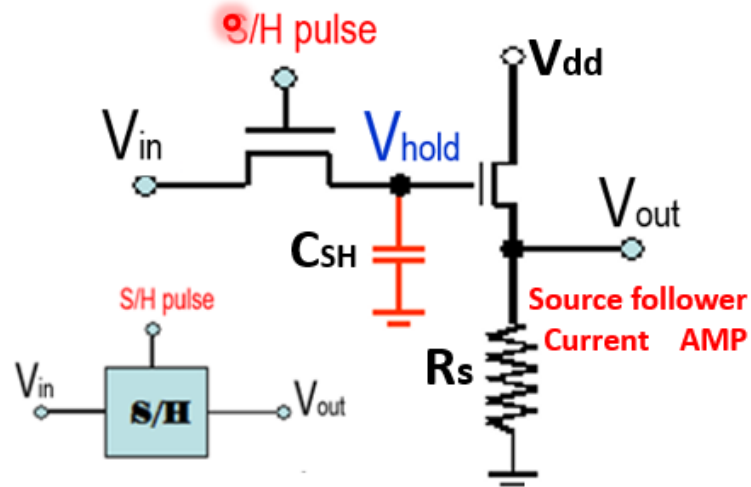
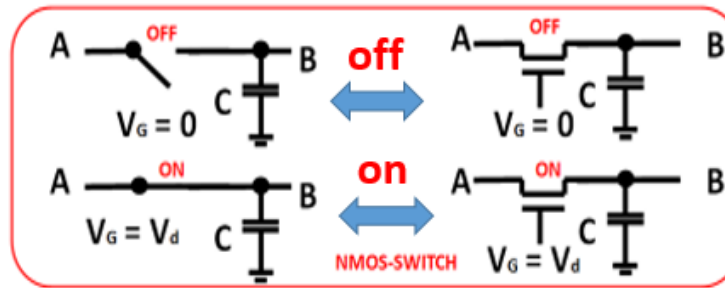
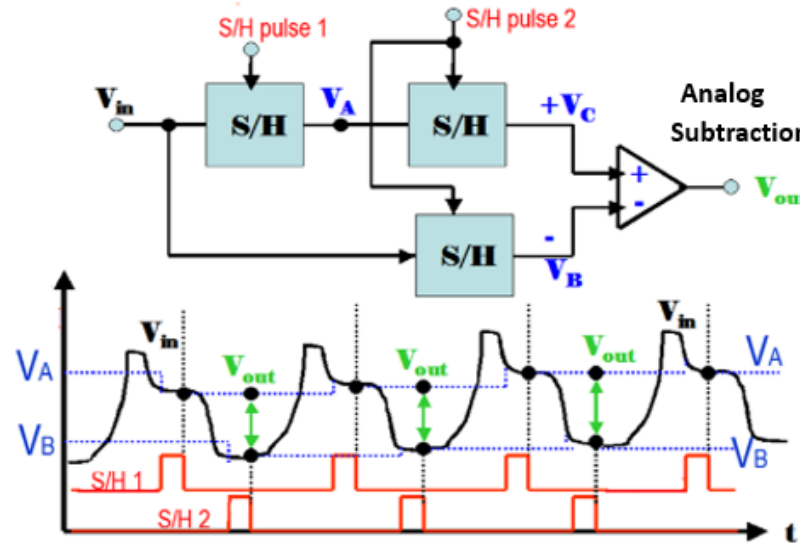

Image Sensor Signals are buried in the clock noises.

MOS Transistor Switch ON/OFF Action



Correlated Double Sampling Hold (CDS)



Hagiwara invented Pinned Photodiode (PPD).

Japanese Patent Applications, JPA1975-127646, JPA1975-127647 and JPA 1975-134985, filed by Yoshiaki Hagiwara at Sony in 1975, show that Hagiwara invented Buried Photodiode (BPD) with the Pinned Surface Hole Accumulation, Pinned Photodiode (PPD) and Hole Accumulation Diode (HAD). It is also evident that Hagiwara invented Global Shutter Scheme of the three level clocking with MOS Capacitor Buffer Memory, clearly shown in JPA 1975-127646 and JPA 1975-127647. It is also evident that Hagiwara et al invented the Electrical Shutter Clocking Scheme by controlling punch-thru action of the in-pixel overflow drain (OFD) voltage as evidenced in JPA 1977-136885.

● NPN transistor Current Amplification

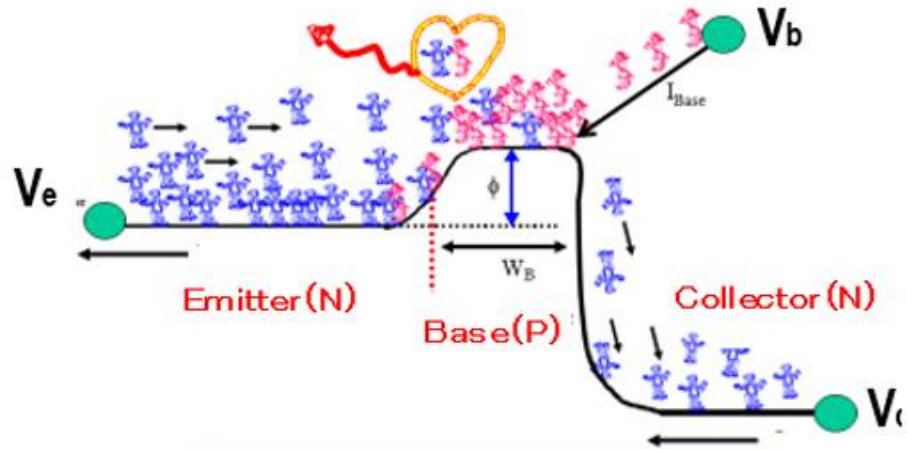

3-D Multi-chips Intelligent CMOS Image Sensor System

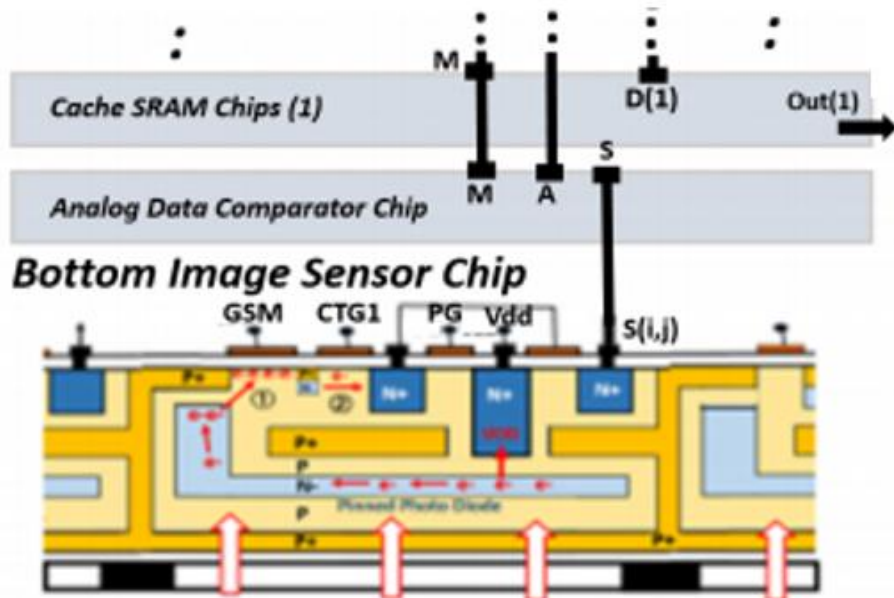

● Low Power CMOS inverter

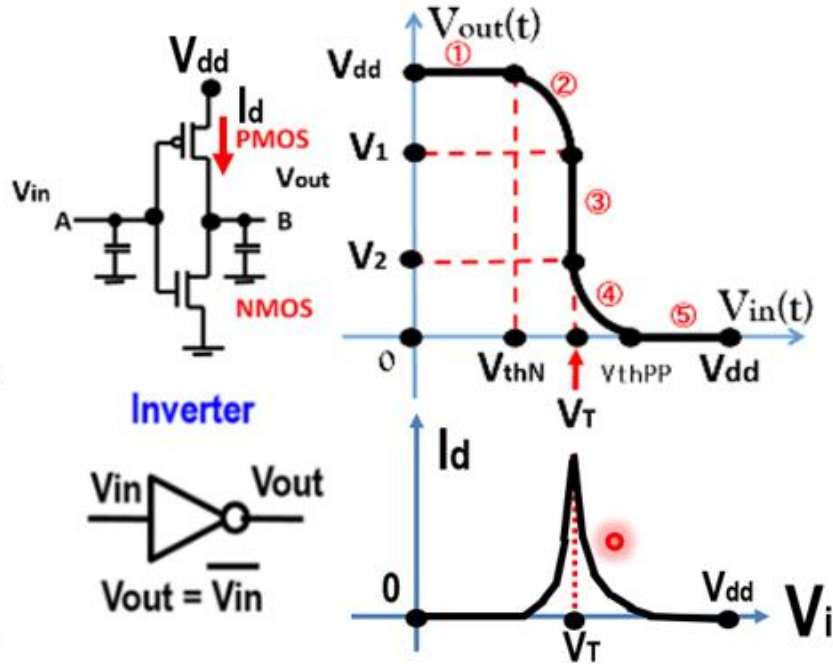

● Water Gate Model for CMOS Inverter

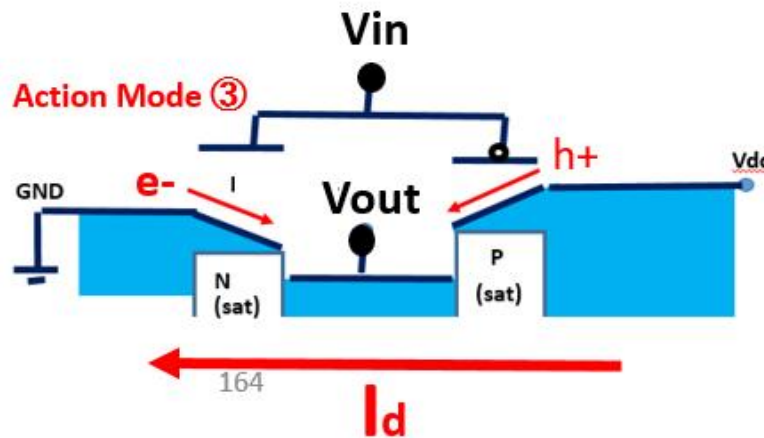

Hagiwara invented Pinned Photodiode (PPD).

Japanese Patent Applications, JPA1975-127646, JPA1975-127647 and JPA 1975-134985, filed by Yoshiaki Hagiwara at Sony in 1975, show that Hagiwara invented Buried Photodiode (BPD) with the Pinned Surface Hole Accumulation, Pinned Photodiode (PPD) and Hole Accumulation Diode (HAD). It is also evident that Hagiwara invented Global Shutter Scheme of the three level clocking with MOS Capacitor Buffer Memory, clearly shown in JPA 1975-127646 and JPA 1975-127647. It is also evident that Hagiwara et al invented the Electrical Shutter Clocking Scheme by controlling punch-thru action of the in-pixel overflow drain (OFD) voltage as evidenced in JPA 1977-136885.

Multichip CMOS Image Sensor Structure for Flash Image Acquisition

Yoshiaki Hagiwara
AIPS
Artificial Intelligent Partner Laboratory
Atsugi-city, Japan
hagiwara-yoshiaki@aipslab.com

Abstract— A new 3D Pinned Photodiode (HAD) CMOS image sensor structure applied in the 3-Dimensional multichip high speed digital flash image data acquisition system is explained and the important features are discussed.

Keywords— Cache SRAM, ADC, Pinned Photodiode, Depletion Photodiode, Buried Photodiode, Back Light Illumination, Global Shutter Buffer Memory, In-pixel Three Transistor Current Source Amplifier.

I. INTRODUCTION

Basically there are five types of photodiode. They are (1) Classic N+Psub junction with serious image lag problem (2) PNsub junction Buried Photodiode (3) PN+sub junction Depletion Photodiode with no image lag feature (4) P+N-P junction Pinned Photodiode with the heavily doped P+ surface hole accumulation with no surface dark current feature and (5) P+N-PNsub junction type hole accumulation diode (HAD) with the vertical overflow drain (VOD) function which is by necessity Buried, Depletion and Pinned Photodiode. Fig. 1 shows the 3D multichip CMOS image sensor structure with the 3D Pinned Photodiode (HAD) image sensors with the MOS capacitor Global Shutter Buffer Memory (GSBM) which was originally invented in 1975.

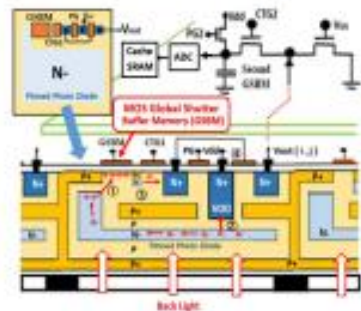

Fig. 1. Cross Section of Buried Depletion Pinned Photodiode stacked with two Global Shutter Buffer Memory (GSBM) and CTG stages in two chip configuration for synchronizing data transfer to the receiving ADC and Cache SRAM chips.

II. HOLE ROLE IN PINNED PHOTODIODE

The importance of holes in the hole accumulation layer HAD structure of Pinned Photodiode was first reported in Hagiwara 1978 paper², and then explained in details by Theurissen⁷ in relationship with IDEM1982⁸ paper and IEDM1984⁹ paper. Today's success of super light sensitive digital imaging is based on the SiO2 exposed pinned window invented by Hagiwara in 1975¹ with the surface P+ hole accumulation HAD layer. Pinned Photodiode was originally invented² in the form of the back illumination scheme as illustrated in Fig. 2.

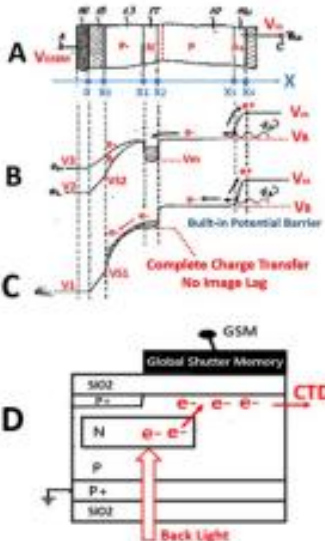

Fig. 2. The P+NPN junction type Buried Depletion Pinned Photodiode with no image lag feature with MOS Capacitor type Global Shutter Buffer Memory (GSBM) invented and defined in Japanese 1975 patent¹ by Hagiwara.



Fig. 3. Exact numerical calculations of Gaussian P+P doping profile D(x), the hole carrier density P(x) and the built-in barrier potential V(x).

III. ROLE OF BUILT-IN POTENTIAL BARRIER IN HAD

Exact numerical calculation of the built-in potential barrier is shown in Fig.3, explaining the hole electron generation and separation in the built-in electric field created by the heavily doped P+ surface hole accumulation HAD.

Note that the local unbalance of the hole concentration P(x) and the impurity boron atom density D(x) gives the local space charge polarization, resulting the built-in potential Vbi. The built-in electric field separates photo electron hole pairs, and resulting in the excellent quantum efficiency of the short wave blue light sensitivity.

Although CCD was just a charge transfer device (CTD), later taken over by CMOS type CTD, both CCD and CMOS image sensors have the super sensitive light detecting feature with very good color reproduction at low light level because of the Pinned Photodiode which was invented and described in Japanese 1975 patent² by Hagiwara.

In solar cells and image sensors, the photo electron and hole pair generation is considered to occur normally in the PN junction depletion region. However, the photo electron and hole pair generation in Pinned Photodiode is performed by an entire different physical principle. In 1975, Hagiwara proposed¹ that the photo electron and hole pair separation can also be achieved in the strong electric field created by the built-in barrier potential as shown in Fig. 2, that was the result of space charge polarization effect explained in Fig. 3.

Photo electrons are separated from holes in the presence of the surface built-in potential barrier near the border of the surface P+ hole accumulation HAD layer. And then, photo generated electrons can drift towards Buried Photodiode, which is the charge collecting storage, by using the holes, that is, positively charged Si ion atoms, as stepping stones, from one Si atom to another, like an energetic space rocket until it loses energy. If the photo electron, generated at the surface built-in potential barrier electric field, is recombined with a hole drifting deep in the bulk silicon, the hole becomes a neutral silicon atom that cannot move. Then, by the silicon bulk thermal neutrality condition, the excess negative space charge is present in the form of the trapped electron by the negatively charged boron or in the external orbit electron in the neutral Silicon atom at high energy state.

Hagiwara invented Pinned Photodiode (PPD).

Japanese Patent Applications, JPA1975-127646,

JPA1975-127647 and JPA 1975-134985, filed by

Yoshiaki Hagiwara at Sony in 1975, show that

Hagiwara invented Buried Photodiode (BPD) with

the Pinned Surface Hole Accumulation, Pinned

Photodiode (PPD) and Hole Accumulation Diode

(HAD). It is also evident that Hagiwara invented

Global Shutter Scheme of the three level clocking

with MOS Capacitor Buffer Memory, clearly shown

in JPA 1975-127646 and JPA 1975-127647. It is also

evident that Hagiwara et al invented the Electrical

Shutter Clocking Scheme by controlling punch-thru

action of the in-pixel overflow drain (OFD) voltage

as evidenced in JPA 1977-136885.

The electron has high energy state and can jump out into the free space. In this way, the excess negative charged electron cannot stay in the neutral silicon atom permanently and can be transferred to the positively charged silicon atom (hole) nearby, acting as stepping stones for the excess electron charge, eventually to drift towards the receiving buried N type charge collecting region. Eventually the excess electron negative charge is collected in the buried N type diffusion storage region. If the electric field of the buried photodiode is near the surface P+ hole accumulation edge, the drifting photo electrons can be quickly and instantly collected in the buried N type charge collecting storage area.

IV. VERTICAL OVERFLOW DRAIN (VOD) FUNCTION

Fig. 4 shows Pinned Photodiode with the vertical overflow drain (VOD), which is also Depletion Photodiode with no image lag feature. The following is the direct English translation of the Patent Claim of the Japanese 1975 patent¹ on Pinned Photodiode (HAD) invented by Hagiwara.

- In the substrate, the first region P1 of the first impurity type is formed, on which the second region N2 of the second impurity type is formed.
- The charge e- from the light collecting part is transferred to the adjacent charge transfer device (CTD). Both are placed along the main surface of the semiconductor substrate.
- In the solid state image sensor so defined, a rectifying junction Jc is formed on the second light collecting region N2 forming the P3 and N2 junction as the emitter junction Jc.
- The result is a photo transistor P3N2P1 structure on the substrate with the N2 and P1 junction as the collector junction Jc. The charge, stored in the base N2 region according to the illuminated light intensity, is transferred to the adjacent charge transfer device.

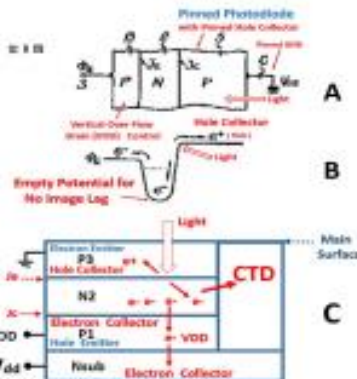

Fig. 4. The P+NPNsub junction type Hole Accumulation Diode (HAD)¹ invented by Hagiwara in 1975.

3D-C2019-0117

2019 International 3D Systems Integration Conference (3D-C)

3D-C2019-0117

2019 International 3D Systems Integration Conference (3D-C)

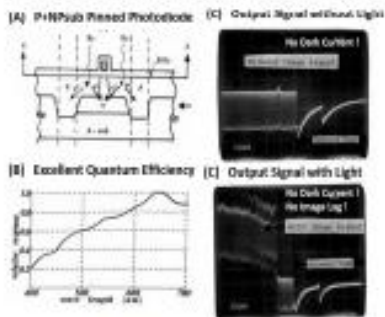

Fig. 5: Reproduction of figures reported in Hagiwara 1978 paper⁷. (A) P+NPsub junction type Pinned Photodiode structure, (B) the Excellent Blue Light Sensitivity (C) no dark current feature and (D) no image lag feature.

It is now well understood that the blue light of short wave length is needed for the satisfactory color reproduction of high image quality. However, the blue light cannot penetrate more than 0.5 micro meter in depth thru the silicon crystal⁷. The built-in surface potential barrier, created by the surface abrupt doping level difference, can in return create the strong electric field at the vicinity of the electron hole pair generation at the silicon surface of 0.3 micro meter in depth, which can effectively separate photo electron and hole pairs, resulting in the excellent quantum efficiency for the blue light needed for the satisfactory color reproduction.

P+NP junction type Pinned Photodiode(A) has the following three very important features, (B) Excellent short wave blue light quantum efficiency, which is the most important feature of Hagiwara 1975 patent⁸, (C) no surface dark current problem and (D) no image lag problem, with also the feature of no surface interface trap (Nst) noise (E). But nothing is new about the feature (D) and (E) since CCD had these two features already by 1975.

In 1966, the in-pixel active source follower amplifier circuit for MOS image sensors was invented by Peter Noble. See Fig. 6.

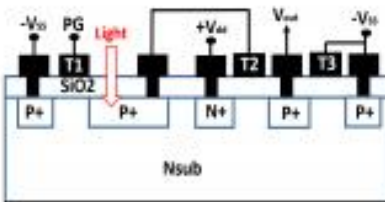

Fig. 6: In-pixel amplifier circuit by Peter Noble, 1966

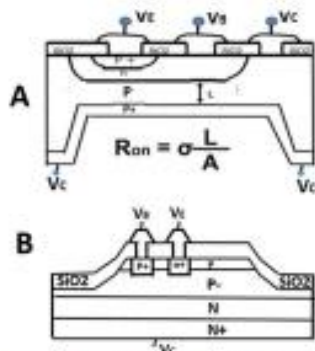

Fig. 7: Bipolar Transistor Process invented and developed by Yoshiyuki Kawana (A) and Toshio Kato (B) in 1950s.

But MOS scaling technology was not so advanced and the CCD type charge transfer device (CTD)⁹ was preferred simply because MOS transistors were too large. However, CCD imager process shown in Fig. 4 was not as simple as MOS process for digital circuits. Complex bipolar transistor process experience was required. See Fig. 7. But now, owing to the advancement of CMOS process scaling, the active circuit of Fig. 6 became the most important element needed to build the modern CMOS image sensors⁸.

V. NPN JUNCTION CHARGE TRANSFER GATING (CTG)

Fig. 8 is a reproduction of the picture drawn in the 1975 patent¹⁰ by Hagiwara. This charge transfer action is very similar to the well-known punch thru operation mode of the PNP junction thyristor. Note that this is very similar to the P+NPsub junction type Pinned Photodiode shown in Fig. 4. Both are the same PNP junction type Pinned Photodiode.

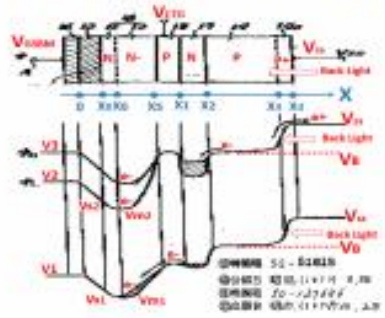

Fig. 8: The P+NPsub junction type Pinned Photodiode¹⁰ with Global Shutter MOS Buffer Memory (GSBM) and the NPN junction type vertical charge transfer gating (CTG).

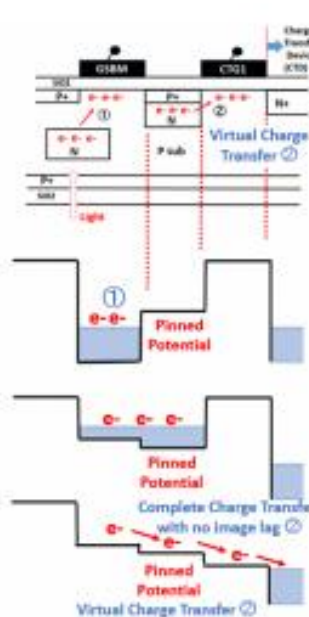

Fig.9: The important concept of Virtual Phase Charge Transfer of the Pinned Photodiode with the complete charge transfer operation mode for no image lag feature, described and invented by Hagiwara 1975 patent^{7, 8, 10, 11}.

VI. PINNED SURFACE VIRTUAL CHARGE TRANSFER

The charge transfer operation with the pinned surface potential for the virtual gating concept is very similar to the CCD charge transfer operation. Fig. 9 shows the virtual charge transfer concept explained by Hagiwara^{10, 11} in 1975. Henocck¹² invented an additional potential barrier stage to achieve the directionality of the virtual phase signal charge transfer operation, which was hinted by Hagiwara 1975 invention⁸ and the virtual phase charge transfer operation of the image lag free Pinned Photodiode⁷ as shown in Fig. 1.

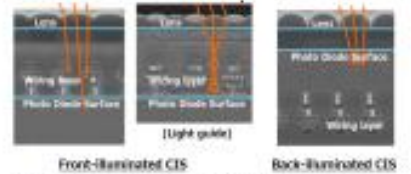

Fig. 10: Cross sectional photos of CMOS image sensors

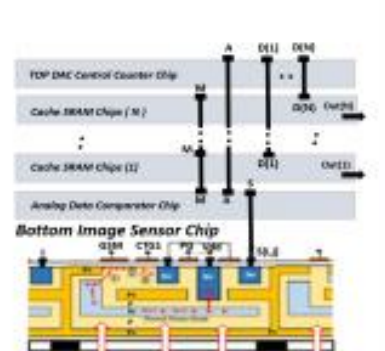

Fig. 11 : Metal Cu pillar signal pass wires thru multichip for the future 3D multichip flash image acquisition system.

VII. 3D MULTICHIP IMAGE SENSOR SYSTEM

Cross sectional photos of back light illuminated CMOS image sensors are shown in Fig. 10 while Fig. 11 shows the 3D multichip CMOS image sensor system. If time sharing scheme is used, we only need one data comparator circuit. However, for fast ADC operations, we must have the in pixel data comparator circuits that have to be spaced in each pixel element area. The comparator circuit is conventional one that can also be used for a simple IR sensor detector as shown in Fig. 12.

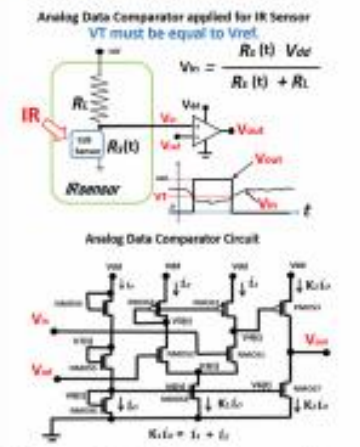

Fig. 12: Conventional Analog Data Comparator Circuit

Hagiwara invented Pinned Photodiode (PPD).

Japanese Patent Applications, JPA1975-127646, JPA1975-127647 and JPA 1975-134985, filed by Yoshiaki Hagiwara at Sony in 1975, show that Hagiwara invented Buried Photodiode (BPD) with the Pinned Surface Hole Accumulation, Pinned Photodiode (PPD) and Hole Accumulation Diode (HAD). It is also evident that Hagiwara invented Global Shutter Scheme of the three level clocking with MOS Capacitor Buffer Memory, clearly shown in JPA 1975-127646 and JPA 1975-127647. It is also evident that Hagiwara et al invented the Electrical Shutter Clocking Scheme by controlling punch-thru action of the in-pixel overflow drain (OFD) voltage as evidenced in JPA 1977-136885.

VIII. CIRCUIT SIMULATION OF ANALOG DATA COMPARATOR

Fig.13 summarized the circuit simulation of the analog data comparator for the various reference voltage Vref values which correspond to the voltage A in Fig. 11. The input voltage Vin which corresponds to the output signal S in Fig.11 is scanned to obtain the value of the threshold voltage VT, which corresponds to the match signal M in Fig.11. With this match signal M, the cache SRAM latches the values of the control counter data D(1) to D(N) in each SRAM level chip. This simulation analysis shows the good circuit performance for the input reference voltage Vref at least in the range of 0 V to 1.5 V.

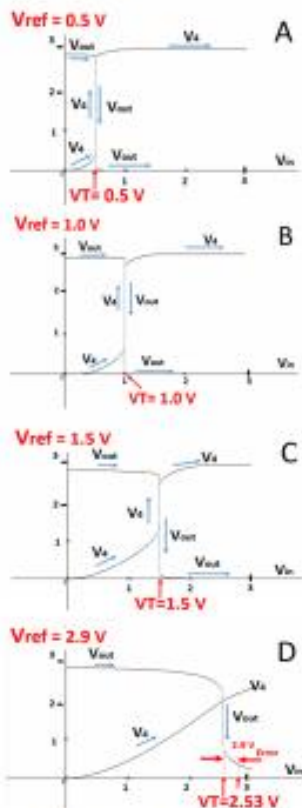

Fig.13: the circuit simulation results of the analog data comparator for the various reference voltage Vref values

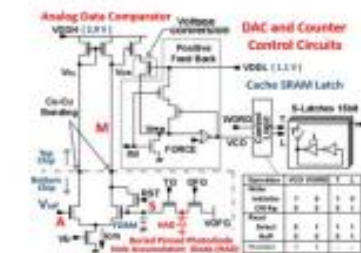
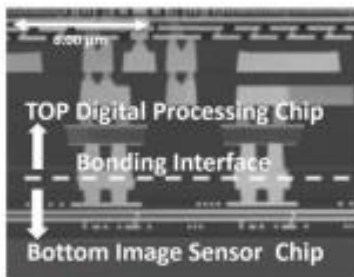

Fig. 14: Cross Sectional View of two chip stacked back-illuminated CMOS Image Sensor¹³⁻¹⁵ with the in-pixel analog comparator control circuits to generate the match signal M from the reference voltage A and the image sensor signal S.

IX. ALL SOLID STATE DIGITAL CAMERA

The 25 nanosecond access time fast Cache 4 Mega Bit SRAM¹⁷ was first developed in 1989, with the dynamic bit line load circuits invented by Miyaji, and was used as the very fast Digital Buffer Memory for the early all solid state digital CCD camera to correct and enhance the picture quality such as jitter correction, color reproduction, pattern correction and image recognition processing system units for industrial and professional applications of high definition television broadcasting level.

Fig. 14 shows the cross sectional view of two chip stacked back-illuminated CMOS image sensor¹³⁻¹⁵ with the in-pixel analog comparator control circuits to generate the match signal M from the reference voltage A and the image sensor signal S, as originally illustrated in Fig. 11 for the future multichip system.

Photo electron and hole generation and separation at the surface electric field is performed at the back side silicon surface of the P+ heavily doped pinned hole accumulation (HAD) layer acting as the Pinned Hole Collector Grounded Terminal. Salient physical parameters are defined in Fig. 15. The all solid state CMOS image sensor technology is now being extended to the 3D multichip flash image acquisition system illustrated in Fig. 1 and Fig. 11.

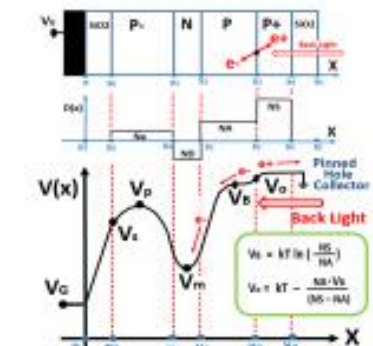

Fig. 15: Electrostatic Analysis of the surface Built-in Barrier Potential Vs and Vb by Depletion Approximation.

X. CONCLUSION

Hole Accumulation Diode⁶ (HAD), with the P+ heavily doped surface hole accumulation layer, invented in 1975, is very important, because first of all it has the excellent short wave length blue light sensitivity feature producing the high picture quality of color reproduction in low level light illumination, which is realized by the photo electron and hole pair generation and separation in the built-in potential barrier⁶ and the electric field at the surface heavily doped P+ hole accumulation HAD. No dark current is the second important feature. And no image lag is the third one since CCD was known to have the no image lag feature already. But CCD itself does NOT have the excellent blue light sensitivity and does NOT have the low dark current feature which the Pinned Photodiode^{1,2,6,10} invented by Hagiwara has.

HAD is defined as the PNPN junction Photodiode with the VOD function. HAD is also by necessity the P+N-P junction Pinned Photodiode with no dark current feature. HAD is also by necessity the PN-P junction Depletion Photodiode defined as Buried Photodiode with no image lag feature. When Hagiwara invented HAD^{1,2,6,10} in 1975, Hagiwara also invented (1) Pinned Photodiode⁶, (2) Depletion Photodiode², (3) Buried Photodiode¹⁰, (4) the in-pixel vertical overflow drain¹ (VOD) function and (5) the in-pixel Global Shutter function^{1, 15}. The surface pinned potential^{1, 6, 15} also serves as the hole collector terminal separating the holes from photo electrons which drift more than the distance estimated by Debye length until being collected into the Buried¹⁰, Depletion² and Pinned⁶ Photodiode (HAD), with the back light illumination scheme¹ which is the most important feature needed to build the super sensitive 3D CMOS image sensor with the high blue-light quantum efficiency and the excellent color reproduction at low light level for fast action pictures with no image lag.

Future AI traffic control system will need at least the high definition 8K image format of 7680H x 4320V, with 33 million pixels, to obtain the details of flash action images, with the in-pixel flash AD converters, and fast Cache SRAM

chips in the 3D multichip CMOS image sensor with the more complex future digital circuit system implementations of the human friendly artificial intelligent partner system¹⁷ (AIPS) to realize the smart AI image sensors for the smart AI robot vision system and home AI security and house cares.

Acknowledgement

The author expresses sincere gratitude to Terushi Shimizu, Yasuhito Ueda, Tadakuni Naraba, Itaya Suzuki, Kato Toshiro and Yoshiyuki Kawama, my dear friends and respectful mentors throughout private and public life at Sony.

REFERENCES

- [1] Japanese 1975-127647 Patent, filed on Oct. 23, 1975 on Buried Depletion and Pinned Photodiode with complete charge transfer and no image lag feature with MOS Capacitor type Global Shutter Buffer Memory (GSBM) function invented by Yoshiaki Hagiwara in 1975.
- [2] Y. Hagiwara, M. Aho, and C. Okada, "A 380Line/80V CCD imager with narrow channel transfer gates," Proc. of the 10th Conference on Solid State Devices, Tokyo, 1979; Japanese J. Appl. Phys., vol. 18, supplement 18-1, pp. 335-340.
- [3] Albert Thomsen, "The Hole Rule", IEDM2005, IEDM Technical Digest, Dec. 2005.
- [4] N. Tanashi et al., IEDM1992 Tech. Digest, pp. 324-32 on Buried Photodiode with no image lag. See also Japanese 1989-123259 patent filed in 1990, filed later than Japanese 1975-124985 patent in 1975.
- [5] R.C. Barkley et al., IEDM Technical Digest, 1984, pp. 28-31 on Pinned Photodiode with the surface P+ hole accumulation layer, a duplicate device defined in the original Japanese 1975-124985 patent.
- [6] Japanese 1975-114985 Patent filed on Nov. 18, 1975 on the P+NPN+Buried Depletion and Pinned Photodiode with the surface P+ hole accumulation layer and the vertical overflow drain (VOD).
- [7] See Fig. 5, p.750, S. M. Sze, "Physics of Semiconductor Devices", 2nd Edition, Wiley.
- [8] K. Ishikawa and Y. Kruka, "One inch 2M pixel CCD with Hyper HAD sensor and Camera System for HDTV", SPIE proc. Vol. 1656, pp.39-40, February 1992.
- [9] K. Yamamoto and H. Sata, "A CMOS Image Sensor with a Simple EPN Radiation Technology and a Hole Accumulation Diode", ISSCC2000, Digest of Technical Papers, pp.302-303, February 2000.
- [10] Japanese 1975-127646 Patent, filed on Oct. 23, 1975 on the P+NPN junction type Buried, Depletion and Pinned Photodiode with the in-pixel MOS capacitor type buffer memory and the vertical NPN junction type charge transfer gating (CTG) for Global Shutter operation scheme.
- [11] Y. Hagiwara, "High-density and high-quality frame transfer CCD imager with very low smear, low dark current and very high blue sensitivity," IEEE Trans. Electron Devices, vol. 43, no. 12, pp. 2122-2130, Dec. 1996.
- [12] J. Miyazaki, "Virtual phase CCD technology," in Proc. IEDM1979, pp. 611-614, Dec. 1979.
- [13] Fumio Miyaji, Yasuhide Matsuyama, Yoshitaka Kanazaki, Kazumasa Sando, Takashi Emori and Yoshiaki Hagiwara, "A 25 million 4 Mega bit CMOSRAM with Dynamic Run-Line Load", ISSCC1989 and J Solid State Circuits, Vol.24, No.5, October 1989.
- [14] M. Sakakibara, et al., "A Back-Illuminated Global-Shutter CMOS Image Sensor with Pixel-Parallel 14b Subthreshold ADC", ISSCC2018, Feb. 2018.
- [15] Y. Kamagai, et al., "Back-Illuminated 2.74 um-Pixel-Pitch Global Shutter CMOS Image Sensor with Charge-Domain Memory Achieving 10x-o-Saturation Signal" IEDM2018, Dec. 2018.
- [16] Y. Kagawa and H. Imamoto, "3D Imagination Technologies for Stacked CMOS Image Sensors", an invited paper at the IEEE 3DIC2019 conference, Oct. 8, 2019, Sendai, Japan.
- [17] Yoshiaki Hagiwara, "The World of Digital Camera for Artificial Intelligent Partner System (AIPS)", published by Senriworks.co.jp, in 2006, ISBN978-4-88359-119-2, 450 pages, Hard Cover 900x90x120.

Hagiwara invented Pinned Photodiode (PPD).

Japanese Patent Applications, JPA1975-127646, JPA1975-127647 and JPA 1975-134985, filed by Yoshiaki Hagiwara at Sony in 1975, show that Hagiwara invented Buried Photodiode (BPD) with the Pinned Surface Hole Accumulation, Pinned Photodiode (PPD) and Hole Accumulation Diode (HAD). It is also evident that Hagiwara invented Global Shutter Scheme of the three level clocking with MOS Capacitor Buffer Memory, clearly shown in JPA 1975-127646 and JPA 1975-127647. It is also evident that Hagiwara et al invented the Electrical Shutter Clocking Scheme by controlling punch-through action of the in-pixel overflow drain (OFD) voltage as evidenced in JPA 1977-136885.

Simulation and Device Characterization of the P+PN+P Junction Type Pinned Photodiode and Schottky Barrier Photodiode

Yoshiaki Hagiwara
AIPS
Artificial Intelligent Partner Laboratory
Atsugi-city, Japan
hagiwara-yoshiaki@aiphb.com, +81-90-2062-5657

Abstract— Process parameter tolerance of semiconductor device is very important for manufacturability and yield. Pinned Photodiode has by definition the pinned surface potential of the low surface dark current feature and the pinned empty potential well of the no image lag feature with the excellent blue light sensitivity of the ideal quantum efficiency. This paper reports simulation and device characterization of the unique P+PN+P junction type Buried, Depletion and Pinned Photodiode with excellent manufacturability, originally invented in 1975. Related various historical photodiode structures are reviewed, including the metal semiconductor Schottky Barrier photo sensor of Au/Ga₂O₃ type in search for the low leakage and dark current photodiode which led the 1975 invention of the low leakage P+PN+P junction Pinned Photodiode by Hagiwara.

Keywords—Buried Depletion Pinned Photodiode, built-in barrier potential, Hole Accumulation Diode (HAD), electron hole pair separation, built-in barrier potential

I. INTRODUCTION

Many failures in device applications are related to loss of the device current blocking capability. The very low reverse leakage current feature of the commercially available Tunnel-based Schottky barrier rectifier switch is a key parameter for device performance, including the high performance required for the super light sensitive, the low surface dark current and the low 1/f noise image sensor at very low light level with the low image lag feature.

Fig. 1 shows the light penetration depth² in the silicon crystal with respect to the incident light wave length. The maximum light penetration depth into the silicon crystal is about 0.2 micro-meter for the blue light of 0.4 micro meter wave length and 37.6 eV photon energy while the light penetration depth is about 8 micro meter for the red light of 0.7 micro meter wave length and 12.3 eV photon energy. To achieve the best color reproduction picture quality for the CMOS image sensors we need a photodiode which can convert the incident blue light energy into the electric energy very efficiently. Various types of photo sensors are compared in Fig. 2. The N+P junction (type A) Esaki Diode has the two states, high and low current modes, in the forward bias. However, it has a relative large leakage current in the reverse bias because both sides of the N+ and P+ regions are very much heavily doped.

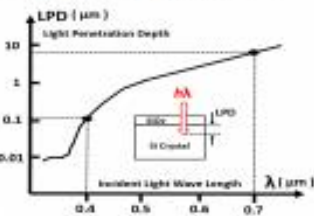

Fig. 1: Light Penetration Depth (LPD) in Silicon Crystal.

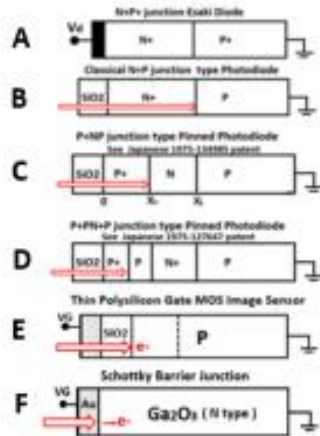

Fig. 2: various types of photo sensor structures.

Classical N+P junction type B photodiode is known to have the serious image lag problem. The type C Pinned Photodiode¹, invented in 1975 by Hagiwara, has the pinned surface potential of the no leakage current feature and the pinned empty potential of the no image lag feature. See Fig. 3. As originally reported by Hagiwara 1978 paper², the P+ surface HAD layer had the Gaussian doping profile with $Q_0 = 2 \times 10^{11} \text{ cm}^{-2}$ and $N_A = 1 \times 10^{18} \text{ cm}^{-3}$ while the buried N region had $N_D = 3 \times 10^{18} \text{ cm}^{-3}$ and $Q_D = 1.7 \times 10^{12} \text{ cm}^{-2}$. The type D Pinned Photodiode has the unique built-in barrier electric field, enhancing the photo electron hole separation at the surface of the silicon crystal for the short wave length blue light.

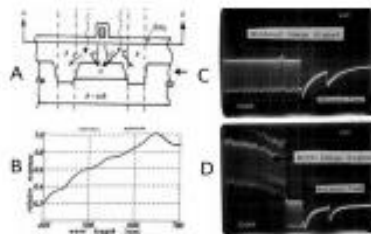

Fig. 3: Features of P+PN junction type Pinned Photodiode

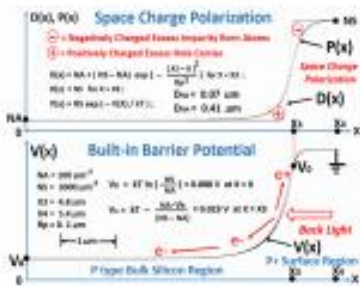

Fig. 4: Exact numerical calculations of Gaussian P+P doping profile $D(x)$, the hole carrier density $P(x)$ and the built-in barrier potential $V(x)$.

The excellent blue light sensitivity is achieved near the silicon surface depth of less than 0.2 micro meter. The substrate doping level was $N_A = 5 \times 10^{18} \text{ cm}^{-3}$. This idea of the unique P+NP junction type Pinned Photodiode was introduced for the first time in 1975 by Hagiwara in his three Japanese patents³ in series, and Hagiwara reported in his 1978 paper² the 38001 x 499V FT CCD image sensor using this P+NP junction (type C) Pinned Photodiode.

However, the actual formation of the doping profile of Pinned Photodiode is very likely to the type D because the neutral ion implantation gives the Gaussian doping profile with smooth tailing slope, effectively resulting in the P+PN+P junction type D profile. See Fig. 4.

The heavily doped surface P+ hole accumulation layer and the relatively heavily doped N+ charge collecting region, connected in between by the lightly doped P region of $N_A = 5 \times 10^{18} \text{ cm}^{-3}$.

Simulation and electric analysis of the P+PNP junction type D Pinned Photodiode was performed. See Fig. 3 which shows the P+P doping profile with the space charge polarization inducing the built-in barrier electric field enhancing the photo electron hole pair separation inside the built-in barrier potential of $kT \ln(N_A/N_D) = 4 \text{ kT ev} = 0.1 \text{ volt}$.

Normally the photo electron and hole pair generation and separation is performed in the electric field inside the depletion region of the PN junction. But the photo electron and hole pair generation and separation of the P+PNP junction (type D) Pinned Photodiode is different and quite unique.

The surface P+P impurity doping slope induces the built-in barrier potential and the resulting built-in barrier electric field enhances the photo electron pair separation at the very near surface region of the silicon crystal to give the excellent blue light sensitivity. This photo electron hole separation mechanism is unique, quite different from the usual photo electron hole pair separation.

The reason why the P+PN+P junction type D Pinned Photodiode can have the excellent blue light sensitivity near the silicon surface depth of 0.2 micro meter is now explained in details. Simulation and the electrostatic analysis is based on the fact that the maximum depth for the blue light penetration into the silicon crystal is 0.2 micro meter which is very close to the surface.

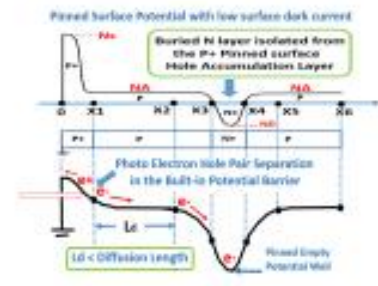

Fig. 5: P+PN+P junction type Buried Pinned Photodiode defined in Hagiwara Japanese 1975-127647 patent.

The life time of the photo generated minority carrier can be measured using the photoconduction effect and the diffusion length L_d can be determined, which is needed for electrons to survive in the majority carrier hole-rich P substrate area. See Fig. 5. Photo electrons are expected to reach the buried N charge collecting region. The situation is similar to the minority carrier electrons injected from the emitter terminal into the majority carrier hole-rich base area of a NPN bipolar transistor. If the base region width is narrow, enough, one or two electrons may recombine with the holes in the base, but the most of the electrons can reach the collector terminal of the strongly reverse-biased depletion region. The N buried region of Pinned Photodiode acts as if the collector region of the NPN bipolar transistor does. This photo electron generation separation physical mechanism is unique and quite different from the ordinary electron hole pair separation in the PN junction depletion region.

II. NO IMAGE LAG FEATURE

Classical N+P junction type B photodiode shown in Fig. 2 is known to have the serious image lag problem. The charge transfer gate has a very large channel resistance and the residual signal charge cannot be transferred completely in the short clock reset time. The remaining small signal charge causes the serious image lag and the fast moving objects cannot be captured and the pictures are blurred. The first attempt was the thin-polysilicon electrode MOS Capacitor type E image sensor structure shown in Fig. 2. However the MOS capacitor type E sensor has inherently the strong surface electric field that induces the serious surface dark current which is caused by the oxide silicon surface positive fixed charge Q_{ox} and the electron trapping states N_{tr} . The oxide silicon interface has the problem of the incomplete atomic crystal disorders inherently which cannot be avoided. Hagiwara proposed in 1975 to use the Schottky Barrier photo sensing type F structure for the interline transfer CCD imager. The idea was hinted by his Caltech undergraduate unpublished research work in 1971 of the Au/Ga₂O₃ Schottky Barrier junction experiment which was expected to have the very low reverse bias leakage current. Based on the conventional photo sensor structures type E and F, Hagiwara proposed in 1975 the P+NP+NP junction type photo sensor structure type C which is the P+NP junction type photodiode combined with the NPN junction type built-in overflow drain (VOD) structure. And in the SSDM1978 paper Hagiwara reported the 38001 x 488V FT CCD image sensor using the P+NP+NP junction type Pinned Photodiode, with the excellent blue sensitivity, the low surface dark current and the low image lag features. See also Fig. 6 for comparison.

Hagiwara invented Pinned Photodiode (PPD).

Japanese Patent Applications, JPA1975-127646,

JPA1975-127647 and JPA 1975-134985, filed by

Yoshiaki Hagiwara at Sony in 1975, show that

Hagiwara invented Buried Photodiode (BPD) with

the Pinned Surface Hole Accumulation, Pinned

Photodiode (PPD) and Hole Accumulation Diode

(HAD). It is also evident that Hagiwara invented

Global Shutter Scheme of the three level clocking

with MOS Capacitor Buffer Memory, clearly shown

in JPA 1975-127646 and JPA 1975-127647. It is also

evident that Hagiwara et al invented the Electrical

Shutter Clocking Scheme by controlling punch-thru

action of the in-pixel overflow drain (OFD) voltage

as evidenced in JPA 1977-136885.

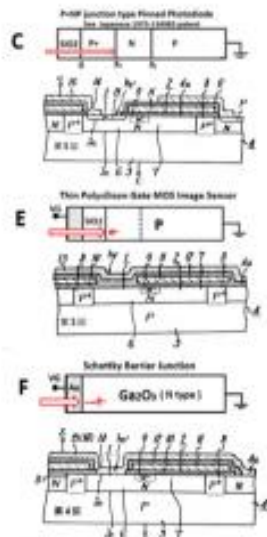

Fig. 6. Cross sectional views of Type C P+NP junction Pinned Photodiode sensor, Type E MOS capacitor photo sensor and Type F Schottky barrier photo sensor.

III. SCHOTTKY BARRIERS ON GALLIUM OXIDE

The surface barrier height of gold chemically prepared for the N type Ga₂O₃ semiconductor was investigated in details at room temperature by (1) photo response, (2) forward current versus voltage and (3) capacitance-voltage methods. Fig. 7 showed the band diagram. The barrier energy was found to be 1.68 eV, with the excellent agreement, within kT of the 0.026 eV, obtained by three methods. The diode non-ideality factor was found to be 1.14 ± 0.03 by current-voltage method.

This value is agreement with the value 1.08 ± 0.04 expected as a result of image force lowering using the free electron concentration 4.1 ± 0.09 × 10¹⁷ cm⁻³ of the un-doped gallium oxide crystal determined by capacitance-voltage measurement. The effective mass m* of electrons was taken as 0.20 m and the relative permittivities of gallium oxide at the optical and low-frequencies were taken as 4 and 10.2 respectively.

The Barrier energies of gold on the chemically prepared Ga₂O₃ was obtained here following the same techniques developed by Neville and Mead for the zinc oxide crystal.

Mead established a semi-empirical approach for predicting the type of contact to be expected at an arbitrary metal-semiconductor interface. Fig. 5 shows the energy band diagram for "no bias" condition for the Au/Ga₂O₃ Barrier.

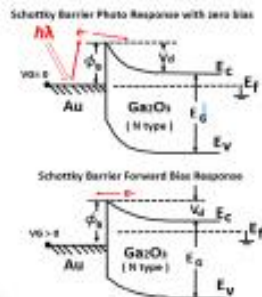

Fig. 7. Au/Ga₂O₃ Schottky Barrier Band Diagram

This approach is now applied for Ga₂O₃. Although five forms of Ga₂O₃ have been reported by 1971, only the monolithic form, having the same structure as alumina, is stable at room temperature.

The results of this analysis show that the barrier height Φ_B is 1.68 eV and the effective carrier concentration of 4.1 ± 0.09 × 10¹⁷ cm⁻³ gives the Fermi level below conduction band edge of 0.1 eV at room temperature. When monolithic light from a monochromator impinges on the semiconductor surface, it induces a short circuit photocurrent in the metal-semiconductor junction.

The square root of the photocurrent normalized to the incident photon flux when plotted as a function of the photon energy results in a straight line for photon energies above (Φ_B + 3 kT). The intercept for zero response of the extrapolated straight line yields a barrier height of 1.68 eV. Typical photo response data is presented in Fig. 8.

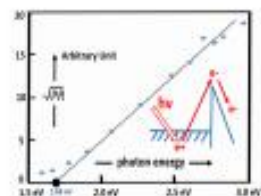

Fig. 8. Photo Response of Ga₂O₃-Au Schottky Barrier

A typical plot of 1/C² as a function of the reverse voltage is shown in Fig. 9. The concentrations was found to be 4.1 ± 0.09 × 10¹⁷ cm⁻³ from the slope using the relation:

$$N_D = \left(\frac{2}{q} \right) \left(\frac{dV}{d(1/C^2)} \right) \quad (1)$$

where S is the barrier area and ε₀ is the low frequency

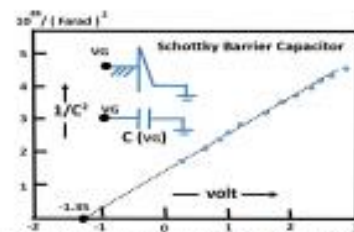

Fig. 9. CV measurement of Ga₂O₃-Au Schottky Barrier

permittivity taken as 10.2 after Neville. See Fig. 9. The extrapolated intercept V₀ is related to the surface barrier energy by the equation

$$V_0 = \frac{\Phi_B}{q} - \frac{kT}{q} \left(1 + \ln \left(\frac{N_D}{N_C} \right) \right) \quad (2)$$

where N_C is the conduction band effective density of states. The intercept V₀ was found to be 1.36 ± 0.09 eV which gives the barrier height Φ_B = 1.70 ± 0.15 eV. Hence, it takes 1.14 ± 0.03 from the forward voltage-current measurements which is in agreement with the value Φ_B = 1.08 ± 0.04 expected for the forward voltages between 0.7 and 1.2 V from the relation

$$V = V_0 + \frac{kT}{q} \left(1 + \ln \left(\frac{I}{I_0} \right) \right) \quad (3)$$

as a result of image force lowering. In Fig. 10, forward current characteristics are displayed at room temperature. The slope gives q/nkT, where n is the diode non-ideality factor, seen to be 1.14 ± 0.03, which is consistent with 1.08 ± 0.04 obtained by the capacitance-voltage method. The extrapolated current density at zero applied bias voltage is given by

$$I_0 = A^* T^2 \exp \left(- \frac{qV_0}{nkT} \right) \quad (4)$$

where A* is the Richardson constant corresponding to the effective mass of the material taken as 0.2 m. Using this equation the barrier height was found to be 1.69 ± 0.04 eV. The deviation of the characteristics from the exponential dependence on the applied voltage with the slope of q/nkT is due to the series resistance which is fairly independent of the current for the range considered.

IV. CONCLUSION

The photo electron hole separation mechanism of the P+NP junction type Pinned Photodiode was explained, which is unique and quite different from the conventional photo electron hole pair separation performed by the electric field inside the PN junction depletion region. Related various historical photodiode structures are reviewed, including the 1971 work on the Ga₂O₃ Schottky barrier photo sensor in search for the low leakage dark current device which led to the 1975 invention of the Pinned Photodiode with the surface P+ heavily doped hole accumulation (HAD) with the vertical overflow drain (VOD).

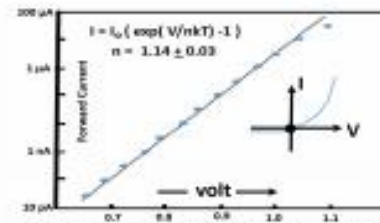

Fig. 10. IV measurement of Ga₂O₃-Au Schottky Barrier

The barrier energy of gold on chemically prepared gallium oxide was shown to be 1.68 eV. The un-doped gallium oxide crystal at room temperature was found to contain 10¹⁷ free electron per cm³. The three experimental techniques showed remarkable agreement forming a constant picture of the Ga₂O₃ - Au interface of the minimal atomic disorders, expecting the very low leakage dark current feature, which is desired for super light sensitive video camera applications at very low light level but with the excellent color reproduction. The N type Ga₂O₃-Au Schottky barrier rectifier was investigated. The very low reverse leakage current feature is a key parameter for the super light sensitive, the low surface dark current and the low image lag, high performance image sensors with excellent color reproduction at very low light level.

Future AI traffic control system will need at least the high definition 8K image format of 7680H x 4320V, with 33 million pixels, to obtain the details of flash action images, with the in-pixel flash AD converters, and fast Cache SRAM chips in the 3D multichip CMOS image sensor with the more complex future digital circuit system implementations of the human friendly artificial intelligent partner system (AIPS) to realize the smart AI image sensors for the smart AI robot vision system and home AI security and house care.

Acknowledgment

The author expresses sincere gratitude to Prof. C.A. Mead and Prof. T.C. McGill, for advising my original 1971 work at Caltech on the Ga₂O₃ - Au Schottky Barrier interface study and characterization, and Yoshiyuki Kawana and Yoshio Kato for supporting my original 1978 work at Sony on the P+NP junction Pinned Photodiode. They are my dear friends and respectful mentors throughout my private and public life.

REFERENCES

- Y. Hagiwara, "Multichip CMOS Image Sensor Structure for Flash Image Acquisition", IEEE ISIC2019 conference in Senda, Japan.
- S. M. Sze, "Physics of Semiconductor Devices", Fig. 5, p.750.
- Japanese 1975-127646, 1975-127647 and 134985 Patents.
- Y. Daimon-Hagiwara, M. Abo, and C. Okada, "A 300Hx400V CCD imager with narrow channel transfer gate", Proc of the 10th Conference on Solid State Devices, Tokyo, 1978; Japanese J. Appl. Phys., vol. 18, supplement 18-1, pp. 335-340.
- R.C. Neville and C.A. Mead, J. Appl. Phys. 41, 9 (1970).
- C.A. Mead, Solid State Electronics-Paragon Press 1968, Vol.8, pp.1023-1033.
- D. Kubby, Solid State Electronics-Paragon Press 1963, Vol. 8, pp.281-295.
- Yoshiaki Hagiwara, "The World of Digital Circuits for Artificial Intelligent Partner System (AIPS)", published by Saitama-shi.jp, in 2016, ISBN978-4-88259-339-2, 456 pages, Hard Cover 9000-yen+tax.

Hagiwara invented Pinned Photodiode (PPD).

Japanese Patent Applications, JPA1975-127646,

JPA1975-127647 and JPA 1975-134985, filed by

Yoshiaki Hagiwara at Sony in 1975, show that

Hagiwara invented Buried Photodiode (BPD) with

the Pinned Surface Hole Accumulation, Pinned

Photodiode (PPD) and Hole Accumulation Diode

(HAD). It is also evident that Hagiwara invented

Global Shutter Scheme of the three level clocking

with MOS Capacitor Buffer Memory, clearly shown

in JPA 1975-127646 and JPA 1975-127647. It is also

evident that Hagiwara et al invented the Electrical

Shutter Clocking Scheme by controlling punch-thru

action of the in-pixel overflow drain (OFD) voltage

as evidenced in JPA 1977-136885.

Symmetrical P+PNPP+ Junction Pinned Photodiode Solar Cell With High Quantum Efficiency

Yoshiaki Hagiwara

AIPS
Artificial Intelligent Partner Laboratory
hagiwara-yoshiaki@aiph.com · Atsugi-city, Japan 243-0201

Abstract

Solar panels on the market today consist of cells made from a single semiconducting material, usually silicon. Since a typical solar cell has the asymmetrical N+PP+ junction type diode structure which absorbs only a narrow band of the solar spectrum, much of sunlight's energy is lost as heat: those panels typically convert less than 20 percent of that energy into electricity. This paper reports the symmetrical P+PNPP+ junction type Pinned Photodiode (PPD) which at least doubles the absorption band of the solar spectrum and more by utilizing the electron hole separation mechanism of the barrier electric field induced by the gradually sloped surface P+P doping profiles on both sides of the silicon wafer. The proposed solar cell structure may achieve more than 60% quantum efficiency.

Conventional N+PNP+ junction type Solar Cell

Blue light cannot penetrate the silicon crystal more than 0.2 micron in depth while red light can penetrate more than 10 micron. If we can collect all the photons within 10 micron depth of the silicon crystal, more than 60% quantum efficiency is possible. A typical solar cell shown in Fig. 1 is very similar to the N+P junction photodiode used in classical MOS image sensors with poor quantum efficiency. Since the surface floating N+N region with no electric field has the potential with stored photo electrons charges, electron hole pairs at the surface cannot be separated and do not contribute to the quantum efficiency. See Fig. 2.

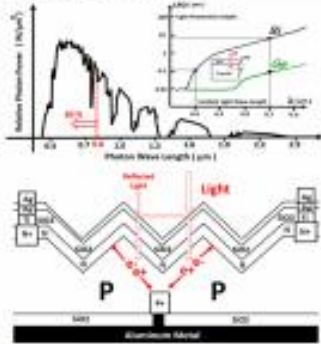

Fig. 1 Sun Light Spectrum and Conversion of Solar Cell

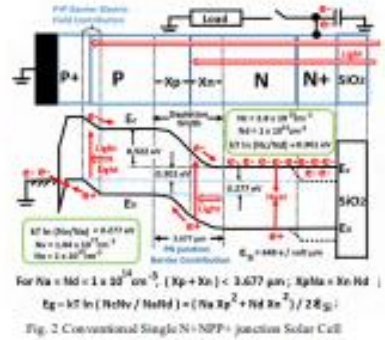

Fig. 2 Conventional Single N+PNP+ junction Solar Cell

Simple P+PNP+ junction type Photodiode

The depletion width of the PN junction is less than 3.7 micron. However, the P+P barrier electric field can also separate the photon generated electron hole pair effectively.

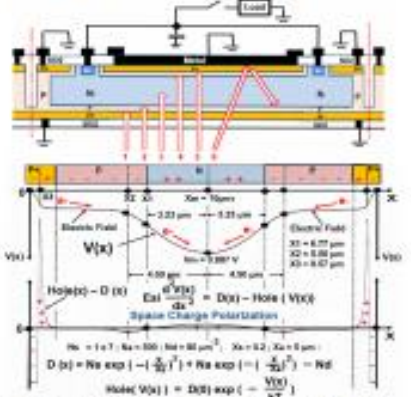

Fig. 3 Symmetrical P+PNPP+ junction type PPD Solar Cell and Exact Numerical Calculation of Potential and Space Charge Polarization.

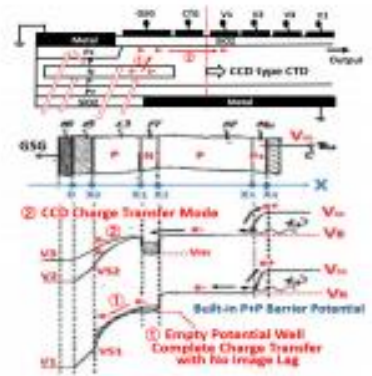

Fig. 4 the P+PNP junction type PPD with the surface P+P barrier electric field used for electron hole pair separation at the surface.

P+PNPP+ junction type Pinned Photodiode Solar Cell

However, the symmetric P+PNPP+ junction type Pinned Photodiode (PPD), as shown in Fig. 3, has two PN junction depletion region side by side, and also with the P+P barrier electric fields in both sides. All of them contribute to quantum efficiency. And a solar cell with more than 60% quantum efficiency may not be a dream. The photoelectrons must be collected into the center lightly doped N region, but must be transferred quickly to the adjacent floating N+ heavily doped outlet, keeping the charge collecting N region always empty of electrons with a fixed or pinned empty potential, V_s .

This symmetric P+PNPP+ junction type Buried Depletion and Pinned Photodiode, originally invented for image sensors with back light illumination^{2,3} scheme as shown in Fig. 4, is very useful and now applied, not only in the solar cell application as described above, but also modern CMOS image sensor applications as shown in Fig. 5.

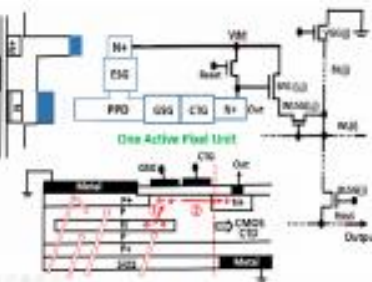

Fig. 5 the P+PNPP+ PPD used in active pixel CMOS image sensor

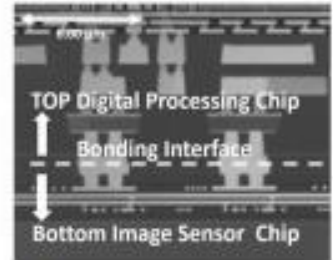

Fig. 6 CMOS image sensor Process applicable to Solar Cell

The symmetric P+PNPP+ junction type Pinned Photodiode (PPD) has three important features⁴ of (1) the excellent blue light sensitivity, (2) no surface dark (leakage) current problem and (3) no serious image lag problem with completely depleted empty potential well with CCD like complete signal charge transfer operation mode. These important features are also applied for the proposed symmetric P+PNPP+ junction type PPD solar cell, keeping everywhere with barrier electric field to separate electron hole pairs in the silicon bulk. See Fig. 3. Thanks to the recent advancements of scaling technology of CMOS fabrication process, the modern CMOS image sensors now have, in each pixel, the electrical shutter gate (ESG), the GSG MOS Buffer Memory, and the active in-pixel source follower current amplifier circuits^{5,6}. Now, with the modern 3D stacked multichip integration technology and the very high quantum efficiency solar cell technology, a self-energy intelligent LSI system may not be a dream in near future.

Acknowledgment

The author expresses sincere gratitude to Terashi Shinzou, Yasuhiro Ueda, Tadakuni Narabu, Kato Toshio, Yoshiyuki Kawana, and Tsugio Makimoto, my dear friends and respectful mentors throughout private and public life at Sony.

References

- 1) Y. Hagiwara, "Simulation and Device Characterization of the P+PNP Junction Type Pinned Photodiode and Schottky Barrier Photodiode", IEEE EDTH2020 conference in Penang, Malaysia in March 2020.
- 2) Japanese 1975-13367 patent on the backlight illuminated N+PNP junction type PPD with the surface N+N barrier electric field.
- 3) Japanese 1975-12495 patent on the P+PNP sub-junction type PPD with the vertical overflow drain (VOD) function and no image lag feature.
- 4) Y. Daino-Hagiwara, M. Abo, and C. Okada, "A 1000x800V CCD imager with narrow channel transfer gates", Proceedings of the 10th Conference on Solid State Devices, Tokyo, 1978; also in the Japanese Journal of Applied Physics, vol. 18, supplement 18-1, pp. 335-348.
- 5) Y. Hagiwara, "Multichip CMOS Image Sensor Structure for Flash Image Acquisition", IEEE JSDC2019 conference in Saitama, Japan.
- 6) Y. Kamegai, et al, "Back-Illuminated 2.74 um Pixel-Pitch Global Shutter CMOS Image Sensor with Charge-Domain Memory Architecture, 10k x Saturation Signal" ISDMS2018, Dec 2018.

Hagiwara invented Pinned Photodiode (PPD).

Japanese Patent Applications, JPA1975-127646, JPA1975-127647 and JPA 1975-134985, filed by Yoshiaki Hagiwara at Sony in 1975, show that Hagiwara invented Buried Photodiode (BPD) with the Pinned Surface Hole Accumulation, Pinned Photodiode (PPD) and Hole Accumulation Diode (HAD). It is also evident that Hagiwara invented Global Shutter Scheme of the three level clocking with MOS Capacitor Buffer Memory, clearly shown in JPA 1975-127646 and JPA 1975-127647. It is also evident that Hagiwara et al invented the Electrical Shutter Clocking Scheme by controlling punch-through action of the in-pixel overflow drain (OFD) voltage as evidenced in JPA 1977-136885.

Simulation and Device Characterization of P+PNPP+ Double Junction Photodiode for Solar Cell Application

Yoshiaki Daimon Hagiwara¹

¹ Artificial Intelligent Partner System Laboratory
Atsugi-city, 243-0201 Japan

Abstract

A conventional single NP junction type photodiode silicon solar cell is known to have a poor quantum efficiency of about 20% because it can utilize only a single narrow depletion width. This paper reports a P+PNPP+ double junction type photodiode which at least doubles the PN junction depletion width and further more by utilizing the electron hole separation mechanism of the barrier electric field created by the sloped surface P+P doping profile, expecting up to 60 % efficiency.

1. Introduction

The short wave length blue light cannot penetrate silicon crystal more than 0.2 μm in depth. Most of the sun light energy is concentrated in the short wave blue light spectrum reaching only the floating N+ silicon surface vicinity of 0.2 micro meter in depth. Moreover, in conventional the N+P single junction type solar cells, the N+P junction depletion region width W_d , as shown in Fig. 1, is very narrow because the large portion of the surface portion of the floating N+ region is used as the photo electron storage region which forms the sea of the photo electrons, with a flat photo electron sea level with no barrier electric field where most of the electron hole pairs are recombined and do not contribute to the solar cell quantum efficiency. This is the main reason why the conventional single junction solar cell¹ has a limitation of a poor quantum efficiency of about 20 %.

2. P+P barrier electric field for photo pair separation

Barrier electric field is needed to separate the photo electron and hole pairs in solar cells. There are two methods to create barrier electric field. One approach is to use the PN junction depletion region shown in Fig. 1. The second approach utilizes the principle applied in a drift field bipolar transistor² base region with the P+P barrier electric field as shown in Fig. 2.

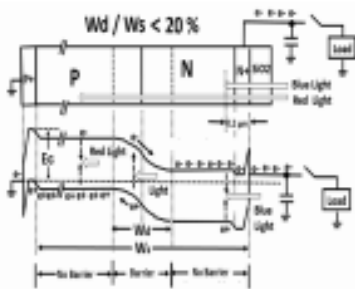

Fig. 1 Conventional Single NP Junction Solar Cell

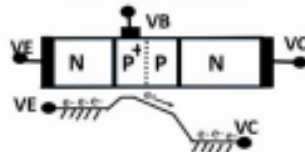

Fig. 2 Drift Field Bipolar Transistor with P+P Barrier Electric Field

The second approach has been applied also in the form of the surface Pinned P+P Hole Accumulation Photodiode³ (HAD) for highly light sensitive imager sensors. See Fig. 3, which shows a cross sectional view of a typical back light illuminated CMOS image sensor in the global shutter scheme with an MOS gate buffer memory (GSG)^{4,5}. The barrier electric field created by the surface P+P impurity doping variation can separate photo electrons pairs created at the near silicon surface P+P region efficiently to achieve the excellent short wave length blue light sensitivity.

Pinned Surface P+PNPP+ double junction type photodiode for solar cell is proposed now in this paper and shown in Fig. 4, which doubles the PN junction depletion region width, creating a very wide PN junction type barrier electric field region needed for the photo electron and hole pair separation.

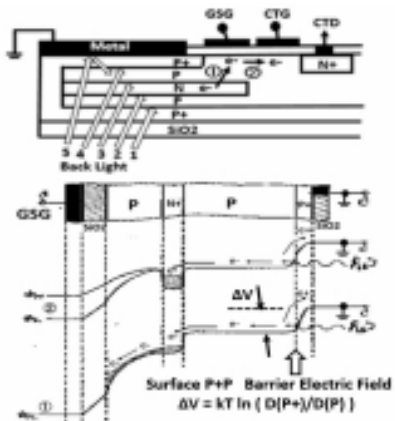

Fig. 3 P+PN+PP+ type Back Light Illumination CMOS Imager



Fig. 4 Doping profile D(x) of P+PNPP+ Solar Cell

3. Numerical Analysis of the P+P barrier electric field

The surface P+P Hole Accumulation Photodiode (HAD) has a smoothly varying shape of Gaussian function given as $G(X) = \exp(-x^2)$. For a double surface ion implantation process we have $D(x) = (N_A - N_D) G(x/R_A) + N_D G(x/R_B)$. The total doping is then $D(x) = D_0(x) + D_1(x) - N_D$ where N_D is the N-type original substrate doping level. Poisson equation⁶ $V(x)/dx^2 = \rho(x)/\epsilon_s$ was solved numerically for the space charge polarization $\rho(x)$ and the electron potential $V(x)$ with $\rho(x) = D(x) - P(V)$. The positive hole carrier density $P(V)$ is given as $P(V(x)) = N_A \exp(-V(x)/kT)$ while the electron charge concentration $N(V(x))$ is zero since the N region is completely depleted and no photo electrons present.

If N_A and N_D were of uniformly doped average values of the surface P+P regions, the surface barrier potential drop can be obtained as $kT \ln(N_A/N_D) = 0.0776$ eV with $kT = 0.0259$ eV. Salient physical parameters were set as $N_D = 100$, $N_A = 10^7$, $N_D = 5 \times 10^7$ all in the unit of $c/\mu m^3$ while $R_A = 0.57$, $R_B = 2.3$, $X_{j1} = 20$ in μm . And the silicon dielectric constant was taken as $\epsilon_{Si} = 648$ eV / μm . Boundary conditions both at $x = 0$ and $x = X_{j1}$ were set as $V(x) = -E_0 = -1.5$ eV, which is at the highest electron energy potential value as shown in Fig. 5.

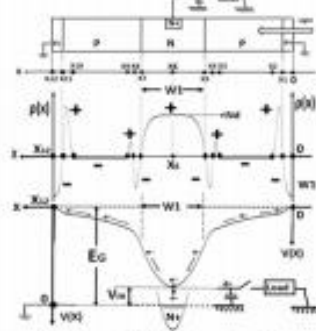

Fig. 5 Numerical Calculations of Space Charge Polarization $\rho(x)$ and Electron Potential $V(x)$

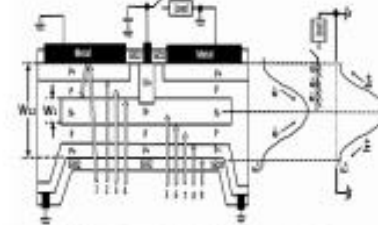

Fig. 6 Various Contributions (1-9) to Quantum Efficiency

Note that the empty potential well of the N region is pinned and is given as $V_{in} = -0.203$ eV. All the photo electrons are to be drained down into the center N+ storage region. Other parameters obtained were $X_{j1} = 0.828$, $X_{j2} = 1.726$, $X_{j3} = 6.315$, $X_{j4} = 6.705$ and $X_{j5} = 7.292$ all in μm . The buried N region width is given as $W_b = X_{j1} - X_{j3} = 5.416$ μm . The charge capacity was computed as $Q_d = 459.5$ $c/\mu m^2$. The average doping level was then given as $\langle N_d \rangle = Q_d/W_b = 84.84$ $c/\mu m^3$ which is close to the initial N type substrate doping level N_D . As shown in Fig. 5, note that for this double ion implantation process, the space charge polarization (+ and -) occurs not only at PN junction depletion edges but also at locations of strong P+P barrier electric field for photo pair separation.

Fig. 6 shows various contributions (1-9) to the quantum efficiency of the solar cell including the backside reflection metal.

4. Conclusion

While the conventional single N+P junction type has the low quantum efficiency of 20 %, the P+PNPP+ double junction type Photodiode (PPD) solar cell is expected at least to double the quantum efficiency, and more by the Pinned Surface P+P Hole Accumulation Diode (HAD) image sensor structure.

The surface P+P barrier electric field contributes more to the quantum efficiency, boosting up to 60 % or more for the short wave blue light energy spectrum, and more drastically at the same time, by preventing the hole electron recombination completely in the empty pinned potential well in the N region.

Acknowledgements

The author expresses sincere gratitude to Prof. T.C. McGill, Prof. C.A. Mead, Dr. Tsugio Makimoto, Kichiro Mutsaers, Yasushi Shimizu, Yasuhiro Ueda, Tadakuni Naraba, Kato Toshio and Yoshiyuki Kawana, my dear friends and respectful mentors in private and public life.

References

- [1] Rohlf, Sven "Estimated Values of the Shockley-Queisser Limit for Single Junction Solar Cells". Solar Energy, 136: 139-147, Feb. 3, 2016.
- [2] Herbert Koenig, "Herk's Bipolar Transistors" IEEE TRANSACTIONS ON ELECTRONIC DEVICES, VOL. 48, NO. 11, NOVEMBER 2001
- [3] Japanese Patent 1975-127646, 1975-127647, and 1975-124985.
- [4] Y. Hagiwara, "Simulation and Device Characterization of the P+PN+PP+ Junction Type Pinned Photodiode and Surface Barrier Photodiode", IEEE EDPSM2019 conference in Penang, Malaysia, March 2019.
- [5] Y. Hagiwara, "Multilayer CMOS Image Sensor Structure for Flash Image Acquisition", IEEE ISIS2019 conference in Saitoh, Japan, Oct 2019.

Hagiwara invented Pinned Photodiode (PPD).

Japanese Patent Applications, JPA1975-127646,

JPA1975-127647 and JPA 1975-134985, filed by

Yoshiaki Hagiwara at Sony in 1975, show that

Hagiwara invented Buried Photodiode (BPD) with

the Pinned Surface Hole Accumulation, Pinned

Photodiode (PPD) and Hole Accumulation Diode

(HAD). It is also evident that Hagiwara invented

Global Shutter Scheme of the three level clocking

with MOS Capacitor Buffer Memory, clearly shown

in JPA 1975-127646 and JPA 1975-127647. It is also

evident that Hagiwara et al invented the Electrical

Shutter Clocking Scheme by controlling punch-thru

action of the in-pixel overflow drain (OFD) voltage

as evidenced in JPA 1977-136885.

Microelectronics for Home Entertainment

Yoshiaki Hagiwara

Sony Corporation, Tokyo Japan
yoshiaki.hagiwara@jp.sony.com

First commercial product for use in consumer products is 0.5 μm LSI chips for 8 mm camcorders in 1995. Then we had 0.35 μm LSI chips for MD products with low voltage operation of 2.0 volt. Now 0.25 μm PlayStation 2 Graphics Synthesizer has eDRAM with 48 GB/sec bandwidth. Fig.19 shows the EmDRAM History.

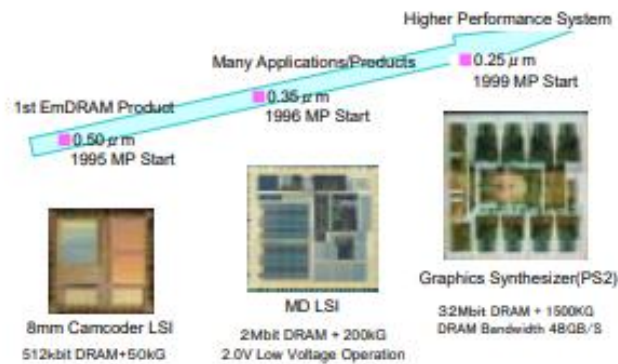

Embedded DRAM History

SONY AIBO 2nd Generation, ERS-210

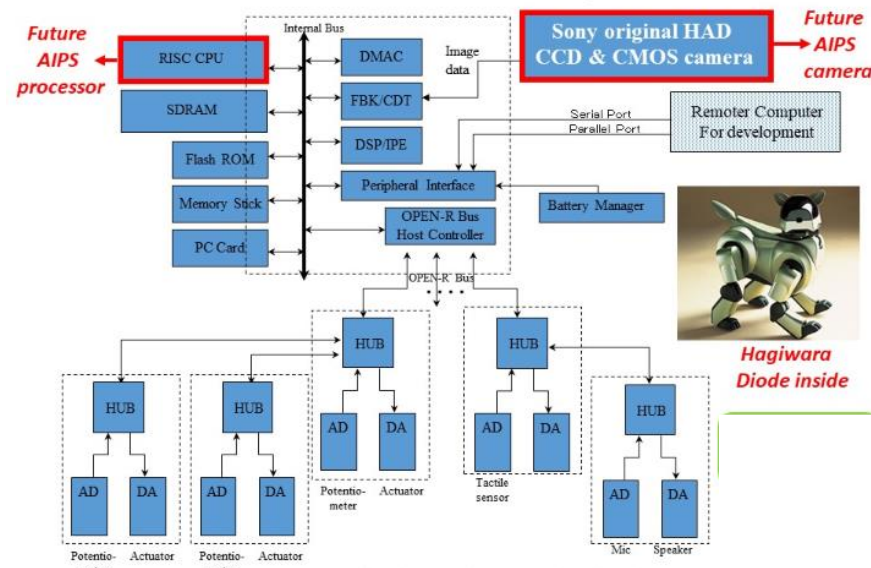

Logical Hardware Block Diagram

Hagiwara invented Pinned Photodiode (PPD).

Japanese Patent Applications, JPA1975-127646, JPA1975-127647 and JPA 1975-134985, filed by Yoshiaki Hagiwara at Sony in 1975, show that Hagiwara invented Buried Photodiode (BPD) with the Pinned Surface Hole Accumulation, Pinned Photodiode (PPD) and Hole Accumulation Diode (HAD). It is also evident that Hagiwara invented Global Shutter Scheme of the three level clocking with MOS Capacitor Buffer Memory, clearly shown in JPA 1975-127646 and JPA 1975-127647. It is also evident that Hagiwara et al invented the Electrical Shutter Clocking Scheme by controlling punch-thru action of the in-pixel overflow drain (OFD) voltage as evidenced in JPA 1977-136885.

SOI Design in Cell Processor and Beyond

Yoshiaki Daimon Hagiwara

Chairman and CEO, AIPS/AINS Consortium

(Ex-Sony Fellow, Semiconductor Strategic Planning)

Hagiwara-Yoshiaki@aiplab.com

45nm Cell/B.E. Die Photo

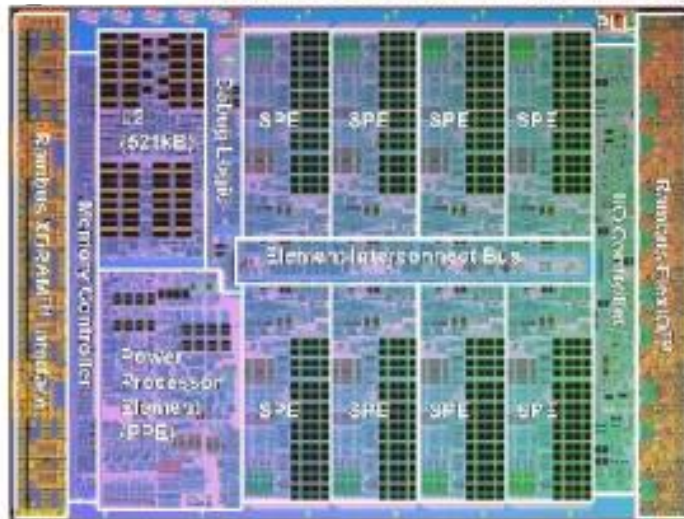

Osamu Takahashi ISSCC2006

By 1994, the games were just starting to move to 0.5-micron processes, while the leading process was 0.35 micron. Eventually over time, the game chips migrated to smaller processes to increase integration and reduce costs.

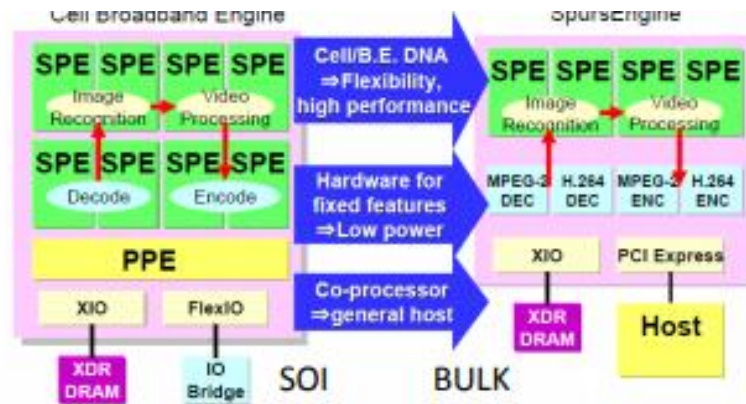

Mitsuo Saito at ICD-ARC Panel May 13, 2008

Cell/B.E. and Toshiba SpursEngine

To address the latency issue, the emotion engine was developed in 1998. This groundbreaking graphics chip needed the latest technologies to achieve its performance and level of integration. By reducing the number of pipeline stages and increasing integration – with 10.5 million transistor and a 128-bit dual vector processor – the Playstation pushed all of the existing limits of the 250-nanometer process.

Hagiwara invented Pinned Photodiode (PPD).

Japanese Patent Applications, JPA1975-127646, JPA1975-127647 and JPA 1975-134985, filed by Yoshiaki Hagiwara at Sony in 1975, show that Hagiwara invented Buried Photodiode (BPD) with the Pinned Surface Hole Accumulation, Pinned Photodiode (PPD) and Hole Accumulation Diode (HAD). It is also evident that Hagiwara invented Global Shutter Scheme of the three level clocking with MOS Capacitor Buffer Memory, clearly shown in JPA 1975-127646 and JPA 1975-127647. It is also evident that Hagiwara et al invented the Electrical Shutter Clocking Scheme by controlling punch-thru action of the in-pixel overflow drain (OFD) voltage as evidenced in JPA 1977-136885.

Reference

Buried Pinned Hole Accumulation Photodiode

Invention 1975

++++
 Japanese Patent Applications 1975-127646, 1975-127647,
 and 1975-134985 invented by Y.Hagiwara

Development 1978

++++
 Y. Hagiwara, M. Abe, and C. Okada,
 “A 380H x 488V CCD imager with narrow channel transfer gates”,
 Proc. The 10th Conference on Solid State Devices, Tokyo, (1978):
 Japanese Journal of Applied Physics, vol. 18, Supplements 18-1,
 pp. 335-340, (1979)
 ++++

Hagiwara invented Pinned Photodiode (PPD).

Japanese Patent Applications, JPA1975-127646,
 JPA1975-127647 and JPA 1975-134985, filed by
 Yoshiaki Hagiwara at Sony in 1975, show that
 Hagiwara invented Buried Photodiode (BPD) with
 the Pinned Surface Hole Accumulation, Pinned
 Photodiode (PPD) and Hole Accumulation Diode
 (HAD). It is also evident that Hagiwara invented
 Global Shutter Scheme of the three level clocking
 with MOS Capacitor Buffer Memory, clearly shown
 in JPA 1975-127646 and JPA 1975-127647. It is also
 evident that Hagiwara et al invented the Electrical
 Shutter Clocking Scheme by controlling punch-thru
 action of the in-pixel overflow drain (OFD) voltage
 as evidenced in JPA 1977-136885.

Reference

Electric Shutter Clocking Scheme

Invention 1975

+++++

Japanese Patent Application 1977-126885

invented by Y. Hagiwara, S. Ochi and T. Hashimoto.

+++++

Development 1987

+++++

Masaharu Hamazaki, Tomoyuki Suzuki, Noriaki Kagawa,
Kikue Ishikawa, Katsurou Miyata, Hideo Kanbe,
"ILT CCD Image Sensor with Electrical Shutter Fuction Control",
Journal of Japanese TV Society, vol.12, no.12, pp.31-36, (1988)

+++++

Hagiwara invented Pinned Photodiode (PPD).

Japanese Patent Applications, JPA1975-127646, JPA1975-127647 and JPA 1975-134985, filed by Yoshiaki Hagiwara at Sony in 1975, show that Hagiwara invented Buried Photodiode (BPD) with the Pinned Surface Hole Accumulation, Pinned Photodiode (PPD) and Hole Accumulation Diode (HAD). It is also evident that Hagiwara invented Global Shutter Scheme of the three level clocking with MOS Capacitor Buffer Memory, clearly shown in JPA 1975-127646 and JPA 1975-127647. It is also evident that Hagiwara et al invented the Electrical Shutter Clocking Scheme by controlling punch-thru action of the in-pixel overflow drain (OFD) voltage as evidenced in JPA 1977-136885.

Invention 1975 Electric Shutter Clocking Scheme

Japanese Patent Application 1977-126885

invented by Y. Hagiwara, S. Ochi and T. Hashimoto.

Japanese Patent JPA 1977-126885 on Electrical Shutter Clocking Scheme invented by Y. Hagiwara, S. Ochi and T. Hashimoto in 1977.

公開特許公報 (A) 昭54-51318

特願 昭52-126885

出願 昭52(1977)9月29日

公開 昭和54年(1979)4月23日

発明者 萩原良昭

発明者 越智成之
同 橋本武夫

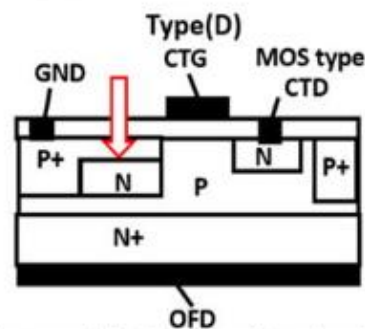
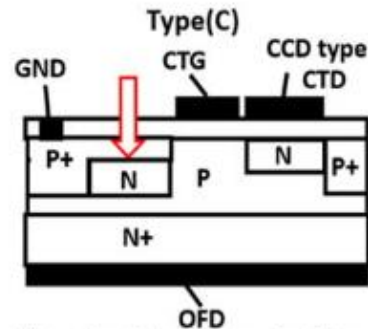
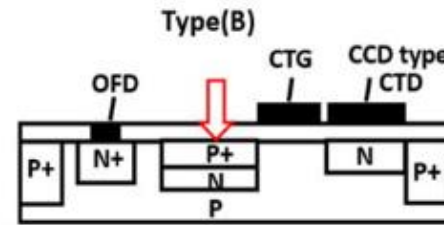
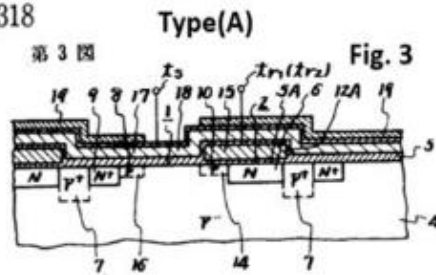

The electric shutter clocking scheme with the complete signal charge draining of no image lag can be achieved by the OFD punch-thru voltage control for any photodiodes, including not only the type (A) of the conventional CCD/MOS photo capacitor but also (B), (C) and (D) type Pinned Photodiodes.

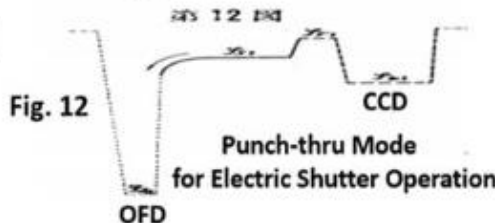
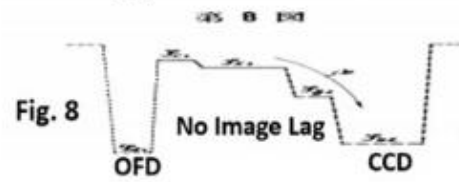
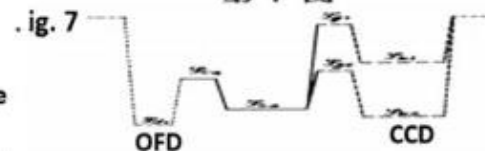

Hagiwara invented Pinned Photodiode (PPD).

Japanese Patent Applications, JPA1975-127646, JPA1975-127647 and JPA 1975-134985, filed by Yoshiaki Hagiwara at Sony in 1975, show that Hagiwara invented Buried Photodiode (BPD) with the Pinned Surface Hole Accumulation, Pinned Photodiode (PPD) and Hole Accumulation Diode (HAD). It is also evident that Hagiwara invented Global Shutter Scheme of the three level clocking with MOS Capacitor Buffer Memory, clearly shown in JPA 1975-127646 and JPA 1975-127647. It is also evident that Hagiwara et al invented the Electrical Shutter Clocking Scheme by controlling punch-thru action of the in-pixel overflow drain (OFD) voltage as evidenced in JPA 1977-136885.

Reference

Active in-Pixel MOS Image Sensor

Invention 1968

+++++

Peter J. W. Noble,

IEEE Transaction of Electron Devices, 15-4, pp.202-209, (1968)

+++++

Development 1990

+++++

Fumihiko Andoh, Kazuhisa Taketoshi, Junichi Yamazaki,
Masayuki Sugawara, Yoshi hiro Fujita, Kohji Mitani,
Yukio Matuzawa, Kenji Miyata, Shuichi Araki,

"A 25 0,000-Pixel Image Sensor with FET Amplification
at Each Pixel for High-Speed Television Cameras",

ISSCC Digest of Technical Papers, pp. 212-213,298, February 1990.

+++++

Hagiwara invented Pinned Photodiode (PPD).

Japanese Patent Applications, JPA1975-127646, JPA1975-127647 and JPA 1975-134985, filed by Yoshiaki Hagiwara at Sony in 1975, show that Hagiwara invented Buried Photodiode (BPD) with the Pinned Surface Hole Accumulation, Pinned Photodiode (PPD) and Hole Accumulation Diode (HAD). It is also evident that Hagiwara invented Global Shutter Scheme of the three level clocking with MOS Capacitor Buffer Memory, clearly shown in JPA 1975-127646 and JPA 1975-127647. It is also evident that Hagiwara et al invented the Electrical Shutter Clocking Scheme by controlling punch-thru action of the in-pixel overflow drain (OFD) voltage as evidenced in JPA 1977-136885.

● Low Power CMOS inverter

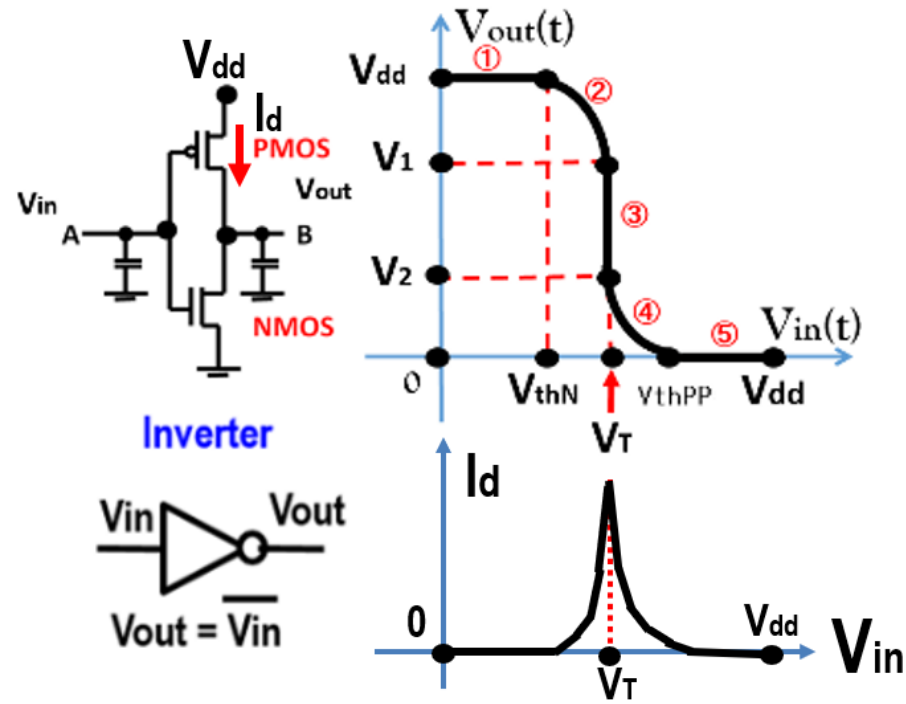

● Source Follower Current Amplifier

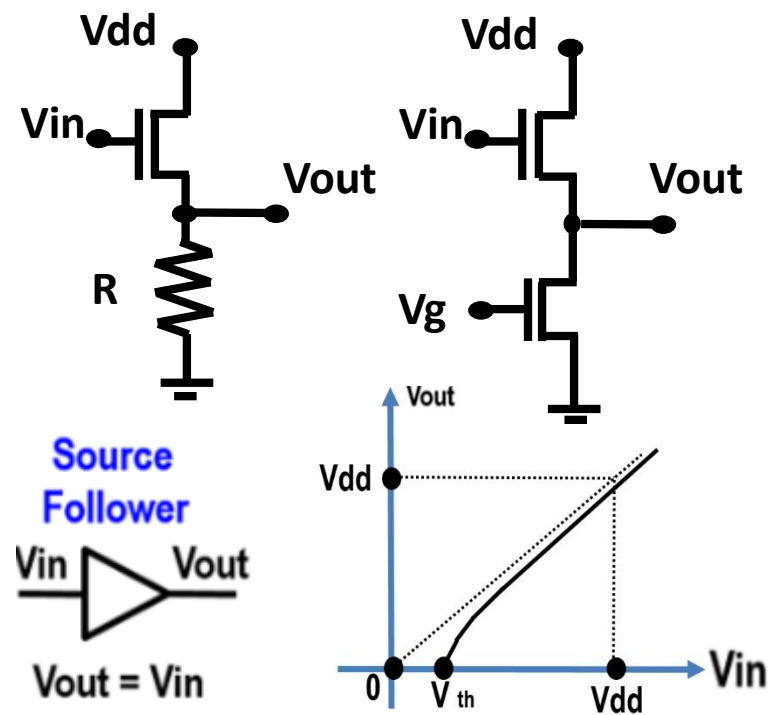

Yoshiaki Hagiwara (AIPS)

Hagiwara invented Pinned Photodiode (PPD).

Japanese Patent Applications, JPA1975-127646, JPA1975-127647 and JPA 1975-134985, filed by Yoshiaki Hagiwara at Sony in 1975, show that Hagiwara invented Buried Photodiode (BPD) with the Pinned Surface Hole Accumulation, Pinned Photodiode (PPD) and Hole Accumulation Diode (HAD). It is also evident that Hagiwara invented Global Shutter Scheme of the three level clocking with MOS Capacitor Buffer Memory, clearly shown in JPA 1975-127646 and JPA 1975-127647. It is also evident that Hagiwara et al invented the Electrical Shutter Clocking Scheme by controlling punch-thru action of the in-pixel overflow drain (OFD) voltage as evidenced in JPA 1977-136885.

History of DRAM Cell (Source Follower)

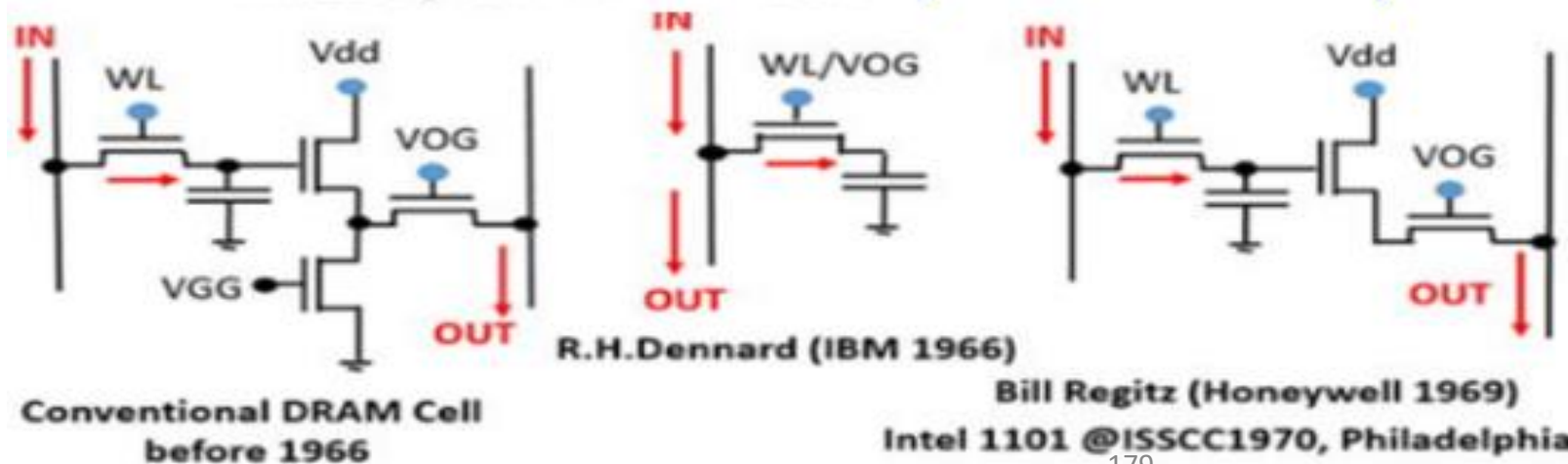

Intel 1101 @ISSCC1970, Philadelphia.

History of Photo Diode Cell (Source Follower)

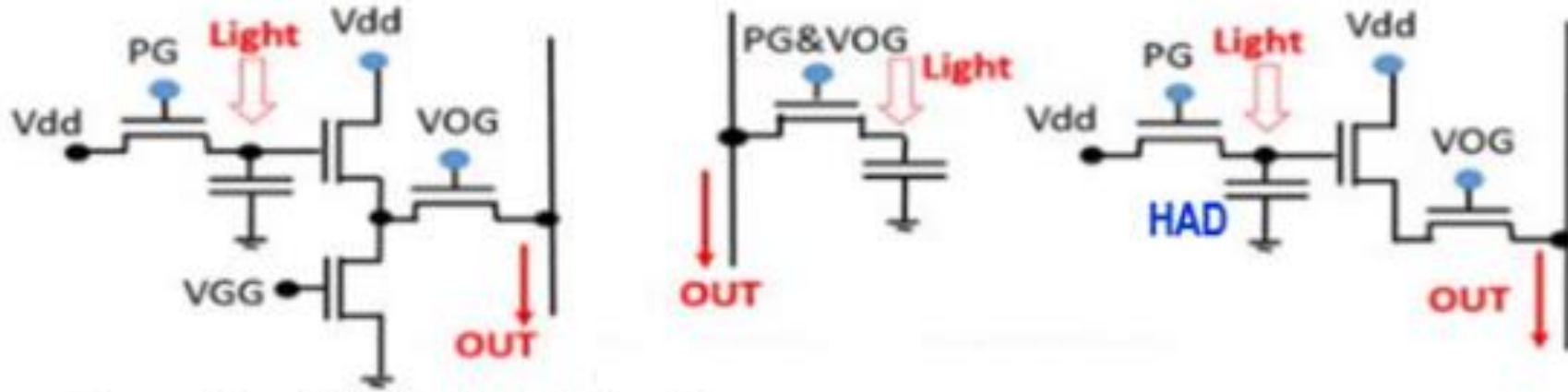

Conventional Active Pixel Circuit
Photo Diode in 1966

after Peter Nobel, 1966~1968

History of DRAM Cell (Source Follower)

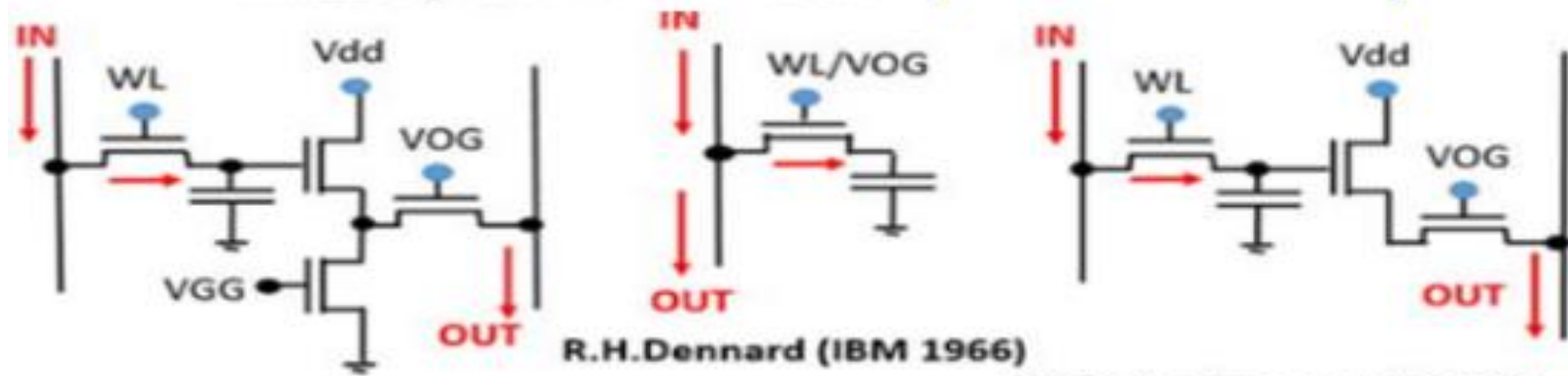

Conventional DRAM Cell
before 1966

R.H.Dennard (IBM 1966)

Bill Regitz (Honeywell 1969)
Intel 1101 @ISSCC1970, Philadelphia.

Hagiwara invented Pinned Photodiode (PPD).

Japanese Patent Applications, JPA1975-127646, JPA1975-127647 and JPA 1975-134985, filed by Yoshiaki Hagiwara at Sony in 1975, show that Hagiwara invented Buried Photodiode (BPD) with the Pinned Surface Hole Accumulation, Pinned Photodiode (PPD) and Hole Accumulation Diode (HAD). It is also evident that Hagiwara invented Global Shutter Scheme of the three level clocking with MOS Capacitor Buffer Memory, clearly shown in JPA 1975-127646 and JPA 1975-127647. It is also evident that Hagiwara et al invented the Electrical Shutter Clocking Scheme by controlling punch-thru action of the in-pixel overflow drain (OFD) voltage as evidenced in JPA 1977-136885.

**Peter Noble invented the in-Pixel Amp MOS Image Sensor in 1968.
See IEEE Transaction Electron devices 15-4 (1968) pp.202-209.**

Hagiwara invented Pinned Photodiode (PPD).

Japanese Patent Applications, JPA1975-127646, JPA1975-127647 and JPA 1975-134985, filed by Yoshiaki Hagiwara at Sony in 1975, show that Hagiwara invented Buried Photodiode (BPD) with the Pinned Surface Hole Accumulation, Pinned Photodiode (PPD) and Hole Accumulation Diode (HAD). It is also evident that Hagiwara invented Global Shutter Scheme of the three level clocking with MOS Capacitor Buffer Memory, clearly shown in JPA 1975-127646 and JPA 1975-127647. It is also evident that Hagiwara et al invented the Electrical Shutter Clocking Scheme by controlling punch-thru action of the in-pixel overflow drain (OFD) voltage as evidenced in JPA 1977-136885.

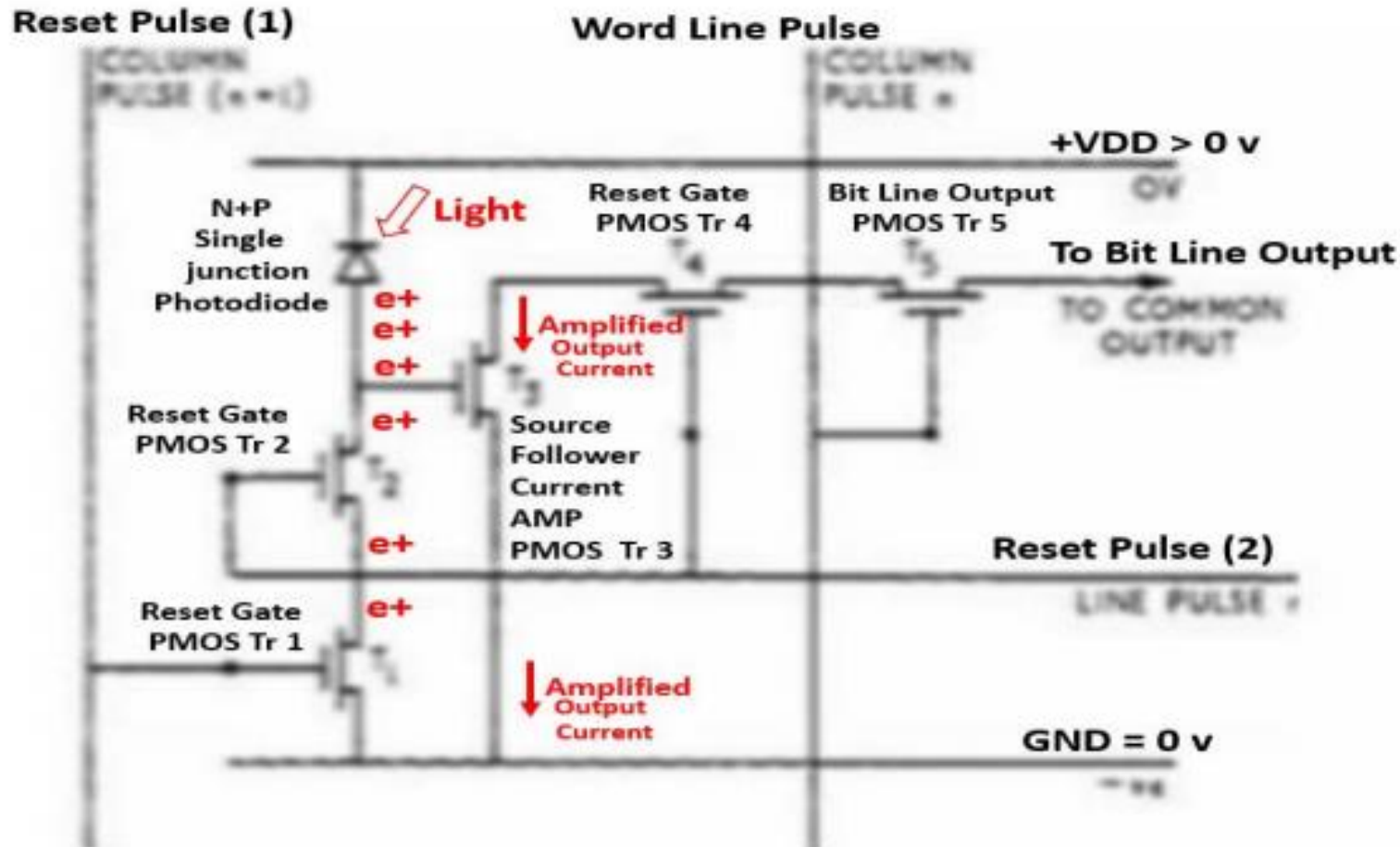

**Active Pixel Sensor (APS) with a photodiode and buffer amplifier
as proposed by Peter Noble in 1968**

Reference

● CCD Image Sensor

Invention and Development 1970

+++++

W.S.Boyle and G.E. Smith,

Bell System Technical Journal, 49, pp.587-593(1970)

+++++

Correlated Double Sampling (CDS) Hold Circuit

Invention and Development 1974

+++++

M.H.White, D.R.Lanpe, F.C.Blaha and I.A.Mack,

"Characterization of Surface Channel CCD Image Arrays at Low Light Level

IEEE Journal of Solid State Circuits, SC-9, pp.1-13 (1974)

+++++

Hagiwara invented Pinned Photodiode (PPD).

Japanese Patent Applications, JPA1975-127646,

JPA1975-127647 and JPA 1975-134985, filed by

Yoshiaki Hagiwara at Sony in 1975, show that

Hagiwara invented Buried Photodiode (BPD) with

the Pinned Surface Hole Accumulation, Pinned

Photodiode (PPD) and Hole Accumulation Diode

(HAD). It is also evident that Hagiwara invented

Global Shutter Scheme of the three level clocking

with MOS Capacitor Buffer Memory, clearly shown

in JPA 1975-127646 and JPA 1975-127647. It is also

evident that Hagiwara et al invented the Electrical

Shutter Clocking Scheme by controlling punch-thru

action of the in-pixel overflow drain (OFD) voltage

as evidenced in JPA 1977-136885.

Correlated Double Sampling Hold by Prof. M. White, 1972

Conventional Single Sampling Hold

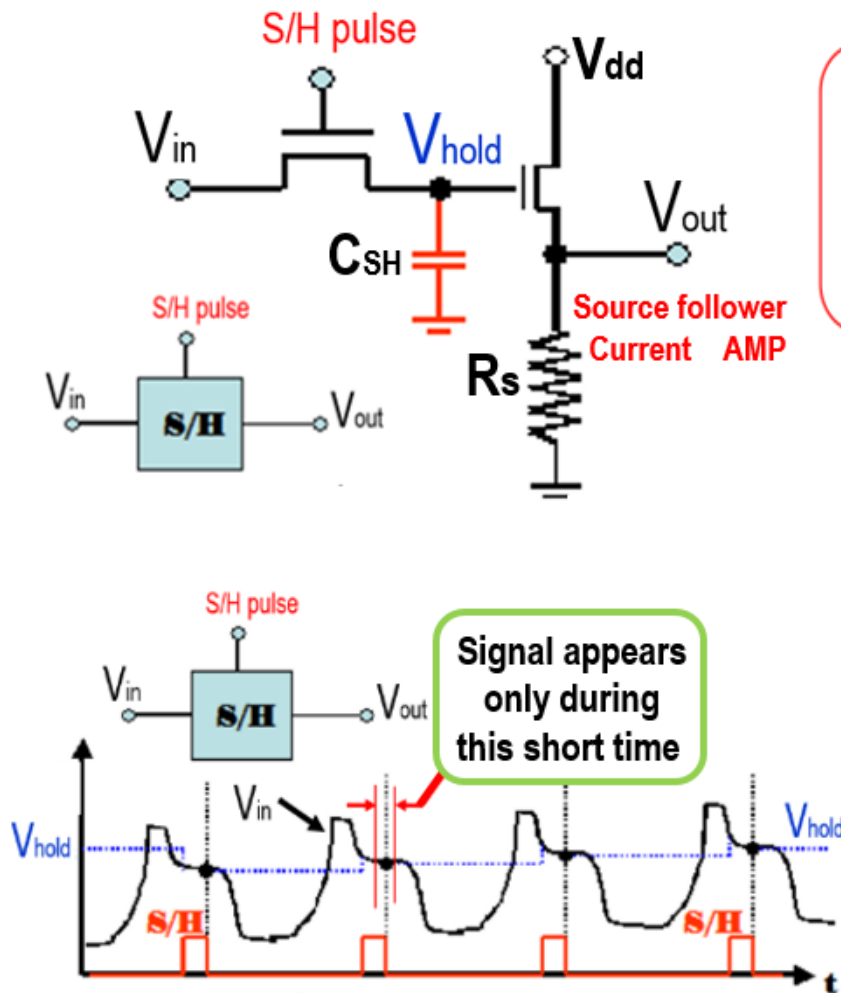

MOS Transistor Switch ON/OFF Action

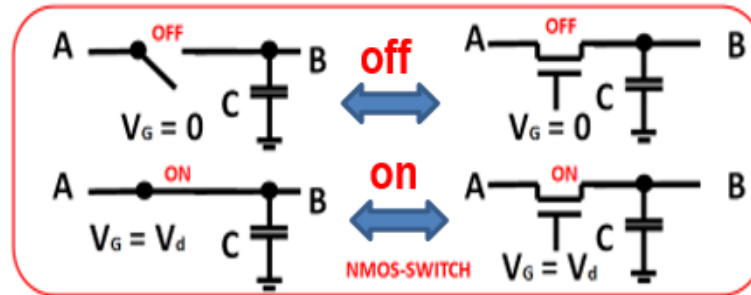

Correlated Double Sampling Hold (CDS)

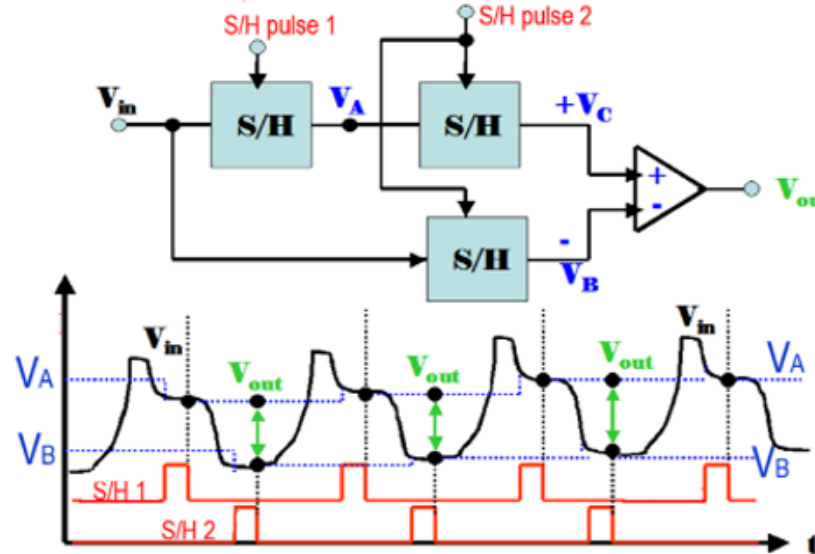

Image Sensor Signals are buried in the clock noises.

Hagiwara invented Pinned Photodiode (PPD).

Japanese Patent Applications, JPA1975-127646, JPA1975-127647 and JPA 1975-134985, filed by Yoshiaki Hagiwara at Sony in 1975, show that Hagiwara invented Buried Photodiode (BPD) with the Pinned Surface Hole Accumulation, Pinned Photodiode (PPD) and Hole Accumulation Diode (HAD). It is also evident that Hagiwara invented Global Shutter Scheme of the three level clocking with MOS Capacitor Buffer Memory, clearly shown in JPA 1975-127646 and JPA 1975-127647. It is also evident that Hagiwara et al invented the Electrical Shutter Clocking Scheme by controlling punch-thru action of the in-pixel overflow drain (OFD) voltage as evidenced in JPA 1977-136885.

27.5 High-Speed Digital Double Sampling with Analog CDS on Column Parallel ADC Architecture for Low-Noise Active Pixel Sensor

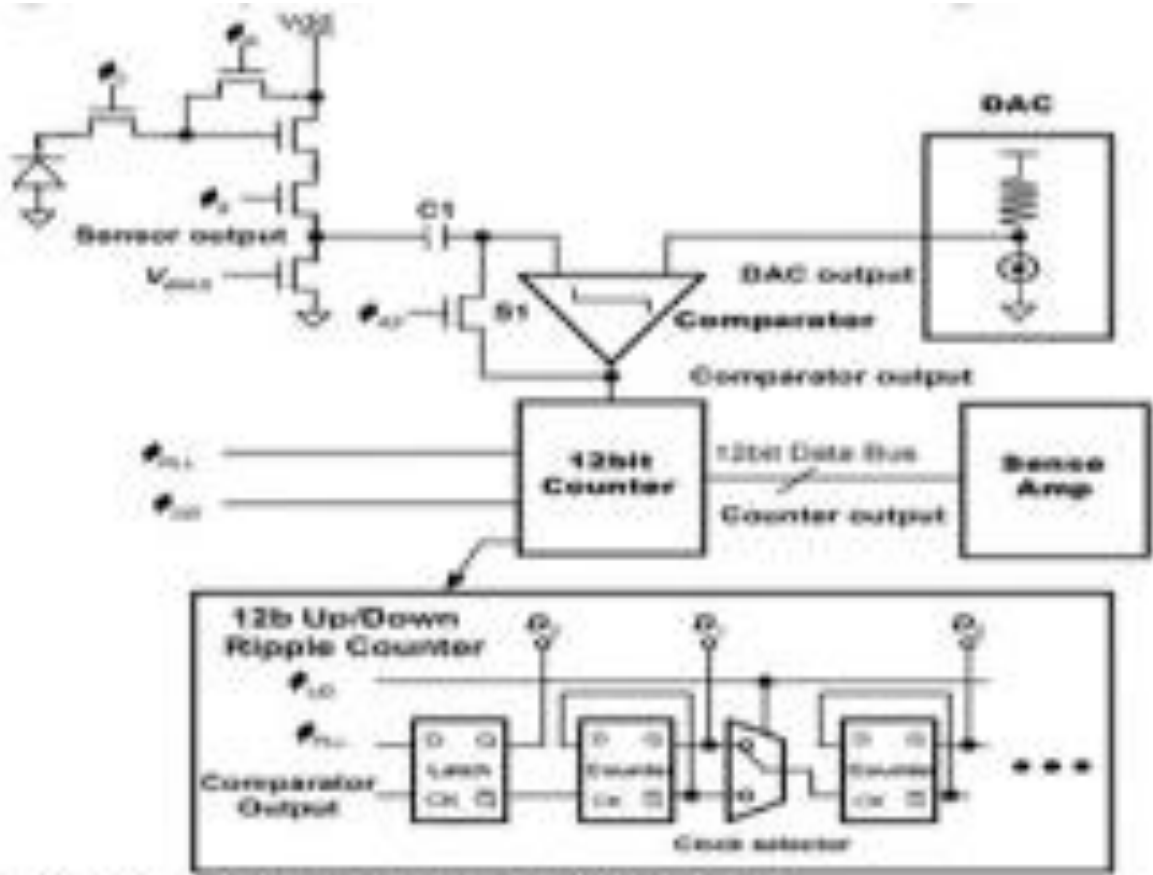

Figure 27.5.2: Column-inline dual CDS architecture.

Hagiwara invented Pinned Photodiode (PPD).

Japanese Patent Applications, JPA1975-127646, JPA1975-127647 and JPA 1975-134985, filed by Yoshiaki Hagiwara at Sony in 1975, show that Hagiwara invented Buried Photodiode (BPD) with the Pinned Surface Hole Accumulation, Pinned Photodiode (PPD) and Hole Accumulation Diode (HAD). It is also evident that Hagiwara invented Global Shutter Scheme of the three level clocking with MOS Capacitor Buffer Memory, clearly shown in JPA 1975-127646 and JPA 1975-127647. It is also evident that Hagiwara et al invented the Electrical Shutter Clocking Scheme by controlling punch-thru action of the in-pixel overflow drain (OFD) voltage as evidenced in JPA 1977-136885.

ISSCC 2006 / SESSION 27 / IMAGE SENSORS / 27.5

ISSCC 2006 / SESSION 27 / IMAGE SENSORS / 27.5

Modern CMOS Image Sensors have (1) HAD (2) APS and (3) CDS.

27.5 High-Speed Digital Double Sampling with Analog CDS on Column Parallel ADC Architecture for Low-Noise Active Pixel Sensor

Yoshikazu Nitta, Yoshinori Muramatsu, Kiyotaka Amano, Takayuki Toyama, Jun Yamamoto, Koji Mishina, Atsushi Suzuki, Tadayuki Taura, Akihiko Kato, Masaru Kikuchi, Yukihiro Yasui, Hideo Nomura, Noriyuki Fukushima Sony, Atsugi, Japan

Traditionally, the advantages of compact image sensors (CISs) over CCDs have been low power consumption and the capability for system integration. Additionally, the image quality of CISs has recently begun to rival and even surpass that of CCDs in the area of high-speed imaging [1]. Compared to high-speed CCDs, CISs utilize the advantage of a column-parallel pixel readout.

The pixels are conventional 4T active pixel sensor (APS) pixels that use hole accumulation diodes (HADs). HADs enable image sensors such as CCDs and CISs to realize ideal properties of low dark current, no kTC noise, and no image lag [2]

Digital double-sampling architecture is proposed to remove device variation and circuit offset that cause vertical FPN [3]. Our column-inline dual-CDS architecture (Fig. 27.5.2) implements digital double-sampling (digital CDS) and analog CDS in parallel columns. A high-speed 297MHz clock is utilized to reduce the double digital sampling period. Additionally, an analog CDS is used to reduce the ADC period for the reset signal V_{EST} by eliminating the analog offset of the pixel and the comparator output.

- (1) HAD (PPD) was invented by Y. Hagiwara in 1975.
- (2) APS was invented by Peter Noble in 1968.
- (3) CDS was invented by M. White in 1972.
- (4) Sony engineers perfected these technologies in 2006.

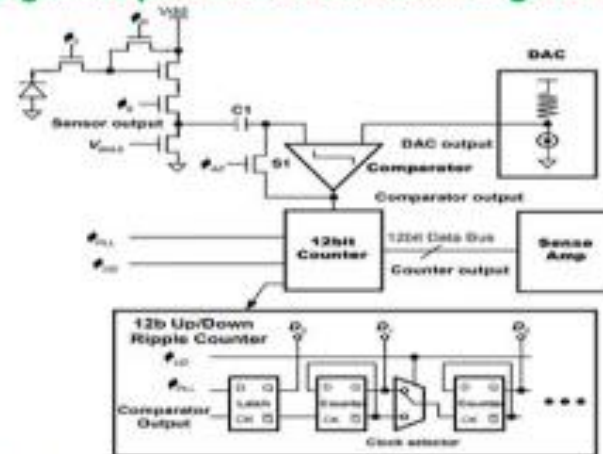

Figure 27.5.2: Column-inline dual CDS architecture.

References:

- [1] A. I. Krymski, N. E. Bock, N. Tu, D. Van Blerkom, E. R. Fossum, "A High Speed, 240frames/s, 4.1-Megapixel CMOS Sensor," *IEEE Trans. Electron Devices*, vol. 50, no. 1, pp. 130-135, Jan., 2003.
- [2] K. Mabuchi, N. Nakamura, E. Funatsu, T. Abe, T. Umeda, T. Hoshino, R. Suzuki, H. Sumi, "CMOS Image Sensor Using a Floating Diffusion Driving Buried Photodiode," *ISSCC Dig. Tech. Papers*, pp. 102-103, Feb., 2004. **Hagiwara 1975 invention (JPA 1975-134985)**
- [3] W. Yang, O. Kwon, J. Lee, G. Hwang, S. Lee, "Integrated 800x600 CMOS Imaging System," *ISSCC Dig. Tech. Papers*, pp.304-305, Feb., 1999.

Hagiwara invented Pinned Photodiode (PPD).

Japanese Patent Applications, JPA1975-127646, JPA1975-127647 and JPA 1975-134985, filed by Yoshiaki Hagiwara at Sony in 1975, show that Hagiwara invented Buried Photodiode (BPD) with the Pinned Surface Hole Accumulation, Pinned Photodiode (PPD) and Hole Accumulation Diode (HAD). It is also evident that Hagiwara invented Global Shutter Scheme of the three level clocking with MOS Capacitor Buffer Memory, clearly shown in JPA 1975-127646 and JPA 1975-127647. It is also evident that Hagiwara et al invented the Electrical Shutter Clocking Scheme by controlling punch-thru action of the in-pixel overflow drain (OFD) voltage as evidenced in JPA 1977-136885.

Why is SONY so strong in Semiconductor Business from the beginning to now ?

(0) Sony could purchase the Bipolar Transistor Patent Right with a very low price of \$ 500 (?) from Bell Lab USA in 1954.

(1) Kawana, Yoshiyuki at Sony invented the low collector On-Resistance N+PN junction type Bipolar transistor by thinning the back side of silicon wafer, a technique now used for the backside illumination CMOS image sensors widely to improve sensitivity.

(2) Kato, Toshio at Sony invented the silicon surface light etching and new SiO₂ Passivation technique for the N+PN junction type Bipolar transistor with the MESA like isolation, which is now known as the shallow trench isolation with the excellent side wall SiO₂ formation to reduce the leakage current.

(3) Hagiwara, Yoshiaki at Sony invented the P+NPNsub junction (thyristor) type Pinned Photodiode, which is identical to SONY Hole Accumulation Diode (HAD), with the built-in vertical overflow drain (VOD) function, the image lag free electric shutter function and good light sensitivity to realize fast action video cameras.

See Japanese Patent 1975-134985

Hagiwara invented SONY HAD which is identical to the Pinned Photodiode which is also the Depletion Photodiode and the Buried Photodiode.

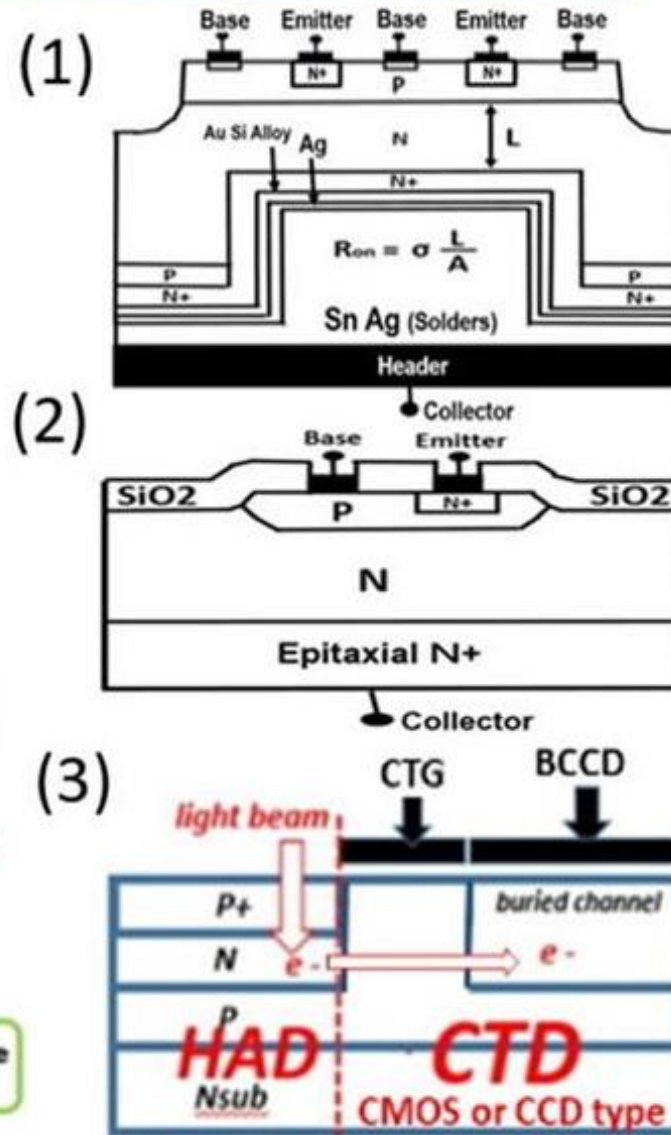

Hagiwara invented Pinned Photodiode (PPD).

Japanese Patent Applications, JPA1975-127646, JPA1975-127647 and JPA 1975-134985, filed by Yoshiaki Hagiwara at Sony in 1975, show that Hagiwara invented Buried Photodiode (BPD) with the Pinned Surface Hole Accumulation, Pinned Photodiode (PPD) and Hole Accumulation Diode (HAD). It is also evident that Hagiwara invented Global Shutter Scheme of the three level clocking with MOS Capacitor Buffer Memory, clearly shown in JPA 1975-127646 and JPA 1975-127647. It is also evident that Hagiwara et al invented the Electrical Shutter Clocking Scheme by controlling punch-thru action of the in-pixel overflow drain (OFD) voltage as evidenced in JPA 1977-136885.



with Prof. James McCaldin @Newport Beach



with Prof. Tom McGill @Caltech Campus

Feynman Physics 1967-1969

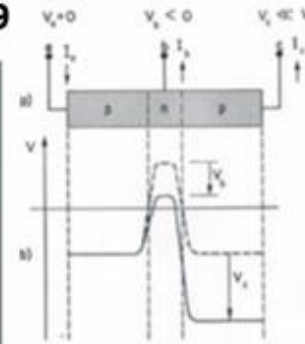

Bipolar Transistor

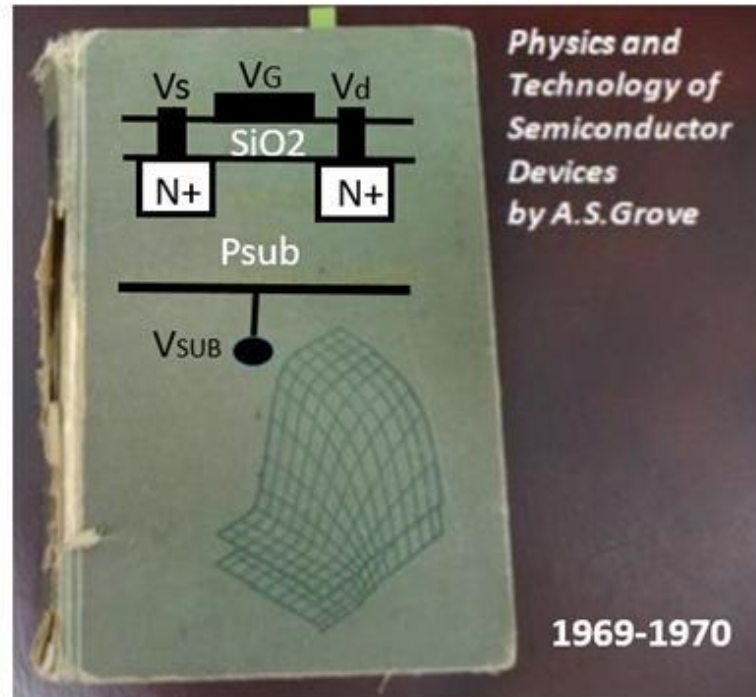

Hagiwara invented Pinned Photodiode (PPD).

Japanese Patent Applications, JPA1975-127646, JPA1975-127647 and JPA 1975-134985, filed by Yoshiaki Hagiwara at Sony in 1975, show that Hagiwara invented Buried Photodiode (BPD) with the Pinned Surface Hole Accumulation, Pinned Photodiode (PPD) and Hole Accumulation Diode (HAD). It is also evident that Hagiwara invented Global Shutter Scheme of the three level clocking with MOS Capacitor Buffer Memory, clearly shown in JPA 1975-127646 and JPA 1975-127647. It is also evident that Hagiwara et al invented the Electrical Shutter Clocking Scheme by controlling punch-thru action of the in-pixel overflow drain (OFD) voltage as evidenced in JPA 1977-136885.

Hagiwara had five important ideas in 1975 for the pinned photodiode sensor structures.



Charge-Coupled Devices and Applications

Chairman
Lewis M. Terman

Tutorial to the importance of the charge-transfer phenomenon is stated by the Morris N. Lubman and the David A. Sarnoff awards this year to the organizers of the charge-coupled and back-gate devices, respectively. The papers in this section concentrate on the former.

Charge-coupled devices are unique among semiconductor devices in that they do not rely on the drift of electrons into circuits, charge is transported and extracted and then used to charge a transistor or readout through a resistor in each case to develop a signal voltage. In

My PhD thesis paper on buried channel CCD at ISSCC1974 in Philadelphia, USA

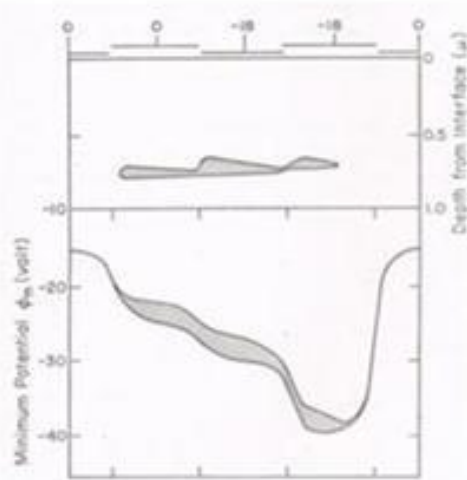

Prof. T. C. McGill



Prof. C. A. Mead

My first publication was a PhD thesis paper published at the ISSCC1974 in Philadelphia in Feb 1974. CalTech/JPL NASA (IBM) computers were used to perform three dimensional (x, y and t) BCCD device simulations for polysilicon and aluminum overlapping gate buried channel CCD structure with the two dimensional Poisson's equation and time domain continuity equation.

Hagiwara invented Pinned Photodiode (PPD).

Japanese Patent Applications, JPA1975-127646, JPA1975-127647 and JPA 1975-134985, filed by Yoshiaki Hagiwara at Sony in 1975, show that Hagiwara invented Buried Photodiode (BPD) with the Pinned Surface Hole Accumulation, Pinned Photodiode (PPD) and Hole Accumulation Diode (HAD). It is also evident that Hagiwara invented Global Shutter Scheme of the three level clocking with MOS Capacitor Buffer Memory, clearly shown in JPA 1975-127646 and JPA 1975-127647. It is also evident that Hagiwara et al invented the Electrical Shutter Clocking Scheme by controlling punch-thru action of the in-pixel overflow drain (OFD) voltage as evidenced in JPA 1977-136885.

See Japanese Patent 1975-134985 (filed on November 10, 1975)

which defines a P+NP/Sub junction type Pinned Photodiode with Vertical Overflow Drain (VOD)

Sony Original
HAD Sensor

HAD = Hole Accumulation Diode

And see also Japanese Patent 1975-127647 (filed on October 23, 1975)

which defines an NPN/Sub junction type Pinned Photodiode with a built-in Global Shutter Function and Back Light Illumination Scheme

128-Bit Multicomparator Chip designed by Caltech Students and fabricated by Intel.

Ref: IEEE Journal of Solid State Circuits, VOL.SC11, No.4, October 1976

Prof. C. A. Mead and Yoshiaki Daimon Hagiwara working on the silicon chip design at Caltech in 1972

492 IEEE JOURNAL OF SOLID-STATE CIRCUITS, VOL. SC-11, NO. 4, OCTOBER 1976

128-Bit Multicomparator

CARVER A. MEAD, RICHARD D. PASHLEY, MEMBER, IEEE, LEE D. BRITTON, YOSHIAKI T. DAIMON, AND STEWART F. SANDO, JR., MEMBER, IEEE

Abstract—A 128-bit multicomparator was designed to perform the search-sort function on arbitrary length data strings. Devices can be cascaded for longer block lengths or parallelized for bit-parallel, word-serial applications. The circuit utilizes a 3-phase static-dynamic shift register cell for data handling and a unique gated EXCLUSIVE-OR circuit to accomplish the compare function. The compare operation is performed bit parallel between a "data" register and a "key" register with a third "mask" register containing don't care bits that disable the comparator. The multicomparator was fabricated using p-channel silicon-gate metal-oxide-semiconductor (MOS) technology on a 107×150 mil chip containing 3350 devices. With transistor-transistor logic (TTL) input, data rates in excess of 2 MHz have been attained. The average power dissipation was 250 mW in the dynamic mode and 300 mW in the static mode.

INTRODUCTION

OVER the past several years, there have been significant amounts of energy devoted to the fabrication of larger and faster semiconductor memories and conventional central processing units (CPU's) in chip form. In the process, many other applications of large-scale integration (LSI) to computer architectures have been neglected [1]. LSI has removed the technological distinction between logic and memory. It is now economically feasible to decentralize the CPU of a computer by replacing much of its maintenance software with functional hardware to improve system efficiency. Presently, an inordinate amount of processing time is spent on organizing and accessing files in peripherals. Peripherals are usually controlled directly by the CPU and have little or no associated logic of their own. A great improvement in this situation can be made by developing peripheral logic units. This would allow each peripheral to accomplish its own internal processing and thus reduce CPU housekeeping duties. This paper describes a 128-bit multicomparator that is designed to perform the search-sort function.

The block diagram of the multicomparator is shown in Fig. 1. The circuit consists of three independently clocked static-dynamic shift registers with associated EXCLUSIVE-OR gating. In operation, the device indicates a match between the data word and the unmasked bits of the key word. The multicomparator is loaded with a key word by serially shifting the word into the key register and locking the register in static mode. While the key word is being loaded, the comparator is enabled by entering zero's in the appropriate locations of the

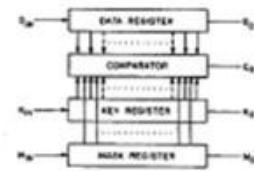

Fig. 1. Block diagram of multicomparator.

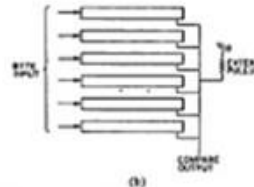
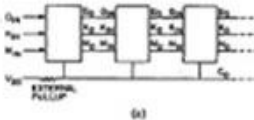

Fig. 2. Possible connections of multicomparator. (a) Cascaded. (b) Bit-parallel, word-serial.

mask register. Masking allows the multicomparator to search for bit strings of varying length and composition. For example, assume it is necessary to search for all words containing a specific 113-bit code. By entering the 113-bit code in the key register and masking out the rest of the comparator, the multicomparator is conformed to search for this code wherever it occurs in the data file. Once the multicomparator is loaded with "key" and "mask" words, the file being searched is serially shifted through the data register. The data words are compared in bit parallel with the unmasked bits of the key word as they pass through the data register. When a match is found, the compare output goes high.

Large multicomparators can be constructed of the 128-bit circuits. Cascaded [Fig. 2(a)], the comparator can be used to search for words longer than 128 bits. By implementing multicomparators in parallel [Fig. 2(b)], a word-serial, bit-parallel



128-bit Multicomparator chip, designed by Hagiwara in 1972-1973 and fabricated by Intel PMOS process.

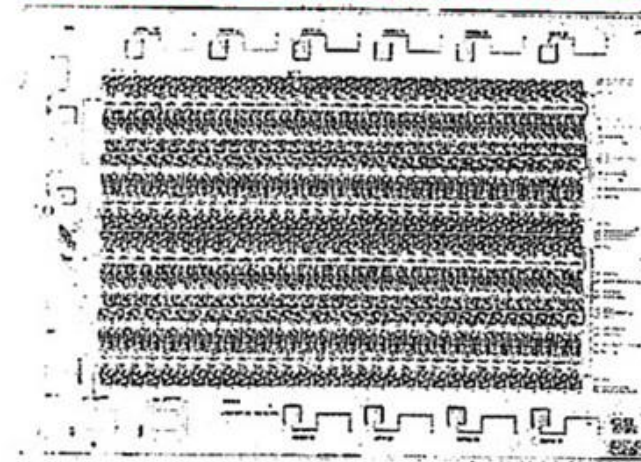

Hagiwara invented Pinned Photodiode (PPD).

Japanese Patent Applications, JPA1975-127646, JPA1975-127647 and JPA 1975-134985, filed by Yoshiaki Hagiwara at Sony in 1975, show that Hagiwara invented Buried Photodiode (BPD) with the Pinned Surface Hole Accumulation, Pinned Photodiode (PPD) and Hole Accumulation Diode (HAD). It is also evident that Hagiwara invented Global Shutter Scheme of the three level clocking with MOS Capacitor Buffer Memory, clearly shown in JPA 1975-127646 and JPA 1975-127647. It is also evident that Hagiwara et al invented the Electrical Shutter Clocking Scheme by controlling punch-through action of the in-pixel overflow drain (OFD) voltage as evidenced in JPA 1977-136885.

Acknowledgements

The author expresses sincere gratitude to Prof. T. C. McGill, Prof. C. A. Mead, Prof. James McCaldin, Dr. Tsugio Makimoto, Kiichiro Mukai, Terushi Shimizu, Yasuhiro Ueda, Dr. Tadakuni Narabu, Kato Toshio, Seiichi Watanabe and Yoshiyuki Kawana, my dear friends and respectful mentors in private and public life.

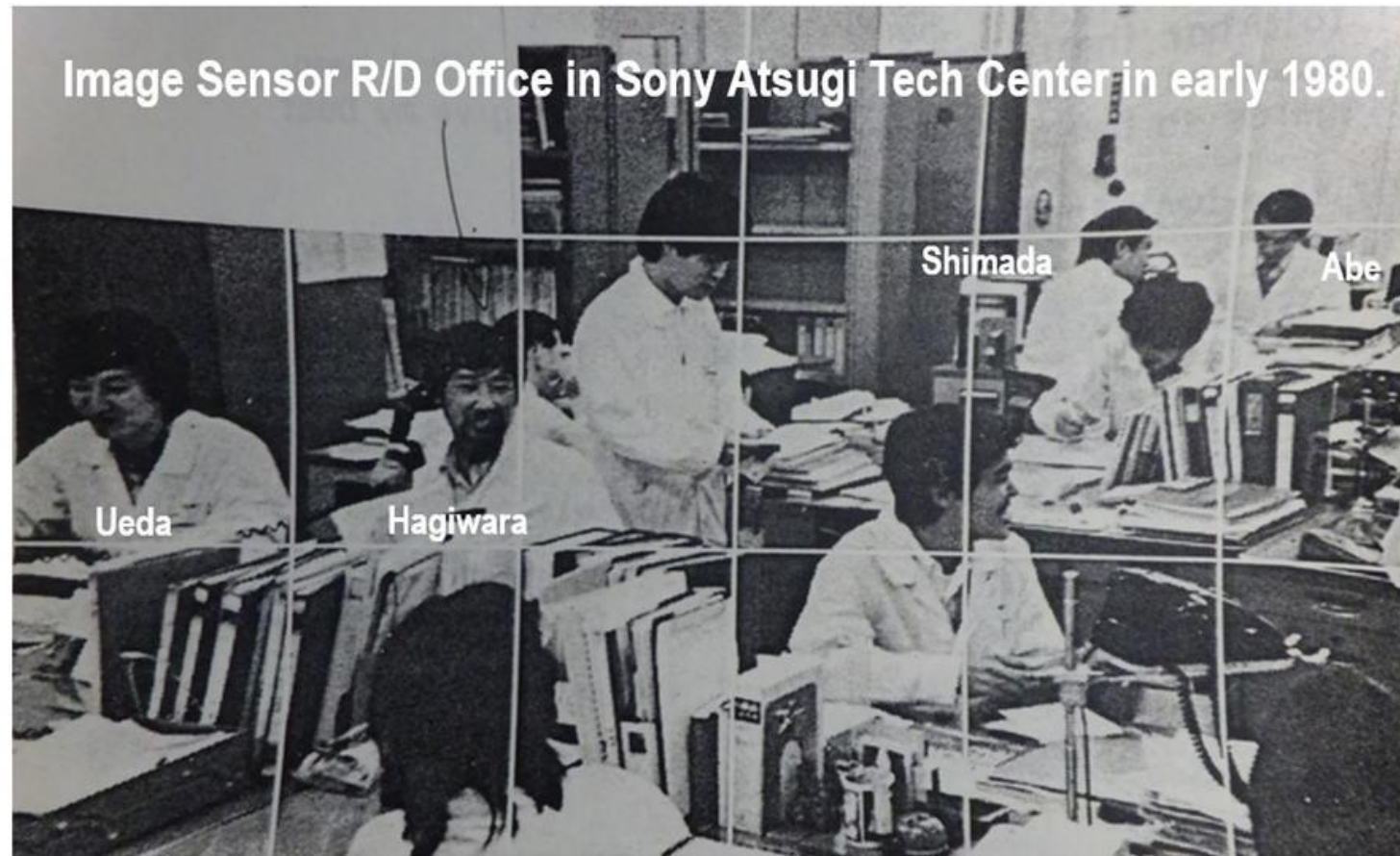

Hagiwara invented Pinned Photodiode (PPD).

Japanese Patent Applications, JPA1975-127646, JPA1975-127647 and JPA 1975-134985, filed by Yoshiaki Hagiwara at Sony in 1975, show that Hagiwara invented Buried Photodiode (BPD) with the Pinned Surface Hole Accumulation, Pinned Photodiode (PPD) and Hole Accumulation Diode (HAD). It is also evident that Hagiwara invented Global Shutter Scheme of the three level clocking with MOS Capacitor Buffer Memory, clearly shown in JPA 1975-127646 and JPA 1975-127647. It is also evident that Hagiwara et al invented the Electrical Shutter Clocking Scheme by controlling punch-thru action of the in-pixel overflow drain (OFD) voltage as evidenced in JPA 1977-136885.

Comparison of Various Light Detecting Photo Sensor Structures

| feature \ type | Classical N+Psub Photodiode | Surface Channel CCD | Buried Channel CCD | Yamada 1978 NPsub | Teranishi 1980 PNPsub | Hagiwara 1975 PNPsub |
|------------------------|-----------------------------|---------------------|--------------------|-------------------|-----------------------|----------------------|
| Blue Light Sensitivity | △ | X | X | ○ | ○ | ○ |
| Low Image Lag | X | ○ | ○ | X | ○ | ○ |
| Surface Dark Current | ○ | X | X | X | ○ | ○ |
| Surface Trap Noise | ○ | X | ○ | X | ○ | ○ |
| Vertical OFD (VOD) | X | X | X | ○ | X | ○ |
| Electrical Shutter | X | X | X | X | X | ○ |

(1) N+P junction Photodiode in 1960s

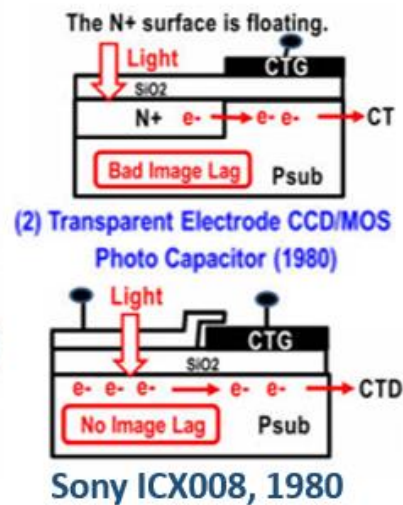
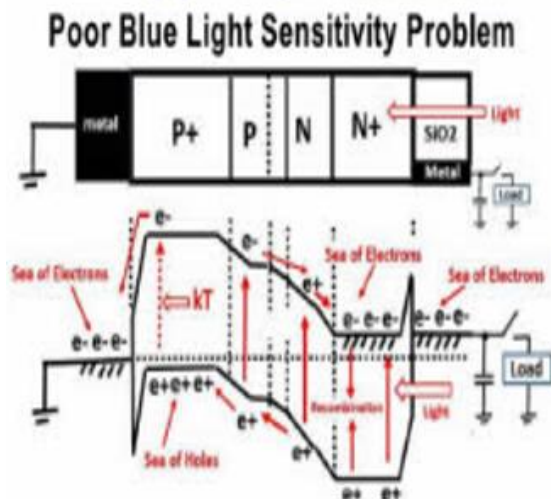

(3) JPA 1975-134985 by Hagiwara

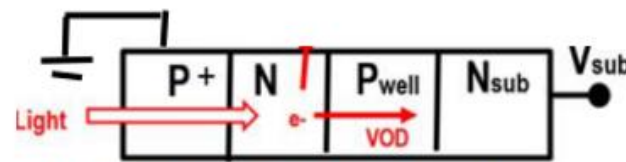

(4) JPA 1978-1971 by Yamada

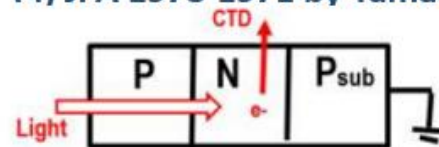

(5) JPA 1980-138026 by Teranishi

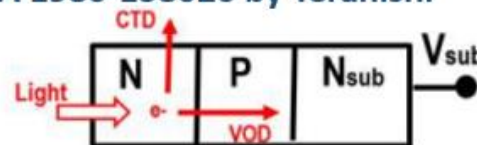

Hagiwara invented Pinned Photodiode (PPD).

Japanese Patent Applications, JPA1975-127646, JPA1975-127647 and JPA 1975-134985, filed by Yoshiaki Hagiwara at Sony in 1975, show that Hagiwara invented Buried Photodiode (BPD) with the Pinned Surface Hole Accumulation, Pinned Photodiode (PPD) and Hole Accumulation Diode (HAD). It is also evident that Hagiwara invented Global Shutter Scheme of the three level clocking with MOS Capacitor Buffer Memory, clearly shown in JPA 1975-127646 and JPA 1975-127647. It is also evident that Hagiwara et al invented the Electrical Shutter Clocking Scheme by controlling punch-thru action of the in-pixel overflow drain (OFD) voltage as evidenced in JPA 1977-136885.

Yoshiaki Daimon Hagiwara BIO in 1976



Yoshiaki Hagiwara was born in Kyoto, Japan, on July 4, 1948. He received the B.S., M.S., and Ph.D. degrees from the California Institute of Technology, Pasadena, in 1971, 1972, and 1975, respectively.

Since 1967, he has served several research groups in the Institute. He worked as a Data Processor in hydraulics from 1967 to 1969, engaging in the analysis of the pressure distribution of solitary waves, the influence of the geological features of a harbor upon the induced standing-wave amplitude in the harbor, and the diffusion mechanism of polluted objects in moving fluids. From 1969 to 1971, he worked as an Experimentalist in the Material Science Department and studied the switching and other electronic properties of newly developed amorphous alloys from the low temperature of 4 K to room temperature. From 1971 to 1975 he was a Research and Teaching Assistant both in the Electrical Engineering and Physics Departments at the California Institute of Technology. In the summer of 1971 and 1973, he visited Sony Corporation, Tokyo, Japan, as a Product-Appraisal Engineer at the Atsui plant and engaged in developments and applications of bipolar technologies in video and power integrated circuits. He is presently with the Sony Corporation, Tokyo, Japan. His interests lie in the areas of digital and linear integrated circuit designs, the physics of microelectronics, and artificial intelligence.

Hagiwara invented Pinned Photodiode (PPD).

Japanese Patent Applications, JPA1975-127646, JPA1975-127647 and JPA 1975-134985, filed by Yoshiaki Hagiwara at Sony in 1975, show that Hagiwara invented Buried Photodiode (BPD) with the Pinned Surface Hole Accumulation, Pinned Photodiode (PPD) and Hole Accumulation Diode (HAD). It is also evident that Hagiwara invented Global Shutter Scheme of the three level clocking with MOS Capacitor Buffer Memory, clearly shown in JPA 1975-127646 and JPA 1975-127647. It is also evident that Hagiwara et al invented the Electrical Shutter Clocking Scheme by controlling punch-thru action of the in-pixel overflow drain (OFD) voltage as evidenced in JPA 1977-136885.

Prof. Yoshiaki Hagiwara at Sojo University was on TV.

The AIPS Self Driving Cars are on the way in near future.

工学者100人が教える
自動車の最先端事情!!

萩原良昭教授

崇城大学
情報学部情報学科

YES

自動運転は可能

100人の字が教えます
情報学部
アカデミー

問.20年以内に全自動運転の車は日本で販売される?

Hagiwara invented Pinned Photodiode (PPD).

Japanese Patent Applications, JPA1975-127646, JPA1975-127647 and JPA 1975-134985, filed by Yoshiaki Hagiwara at Sony in 1975, show that Hagiwara invented Buried Photodiode (BPD) with the Pinned Surface Hole Accumulation, Pinned Photodiode (PPD) and Hole Accumulation Diode (HAD). It is also evident that Hagiwara invented Global Shutter Scheme of the three level clocking with MOS Capacitor Buffer Memory, clearly shown in JPA 1975-127646 and JPA 1975-127647. It is also evident that Hagiwara et al invented the Electrical Shutter Clocking Scheme by controlling punch-thru action of the in-pixel overflow drain (OFD) voltage as evidenced in JPA 1977-136885.

Artificial Intelligent Partner System(AIPS) Home Page Top
 hagiwara-yoshiaki@aiplab.com



Hagiwara invented Pinned Photodiode (PPD).

Japanese Patent Applications, JPA1975-127646, JPA1975-127647 and JPA 1975-134985, filed by Yoshiaki Hagiwara at Sony in 1975, show that Hagiwara invented Buried Photodiode (BPD) with the Pinned Surface Hole Accumulation, Pinned Photodiode (PPD) and Hole Accumulation Diode (HAD). It is also evident that Hagiwara invented Global Shutter Scheme of the three level clocking with MOS Capacitor Buffer Memory, clearly shown in JPA 1975-127646 and JPA 1975-127647. It is also evident that Hagiwara et al invented the Electrical Shutter Clocking Scheme by controlling punch-thru action of the in-pixel overflow drain (OFD) voltage as evidenced in JPA 1977-136885.

Image Sensor Story

Yoshiaki Hagiwara

AIPS



Thank you !

Hagiwara invented Pinned Photodiode (PPD).

Japanese Patent Applications, JPA1975-127646, JPA1975-127647 and JPA 1975-134985, filed by Yoshiaki Hagiwara at Sony in 1975, show that Hagiwara invented Buried Photodiode (BPD) with the Pinned Surface Hole Accumulation, Pinned Photodiode (PPD) and Hole Accumulation Diode (HAD). It is also evident that Hagiwara invented

Global Shutter Scheme of the three level clocking with MOS Capacitor Buffer Memory, clearly shown in JPA 1975-127646 and JPA 1975-127647. It is also evident that Hagiwara et al invented the Electrical Shutter Clocking Scheme by controlling punch-thru action of the in-pixel overflow drain (OFD) voltage as evidenced in JPA 1977-136885.